

HD VIDEO SWITCHER V-8HD

Version 2.0 and later



Panel Descriptions	2
Top Panel / Side Panel.....	2
Rear Panel (Connecting Your Equipment)	4
Multi-View Monitor Display	6
Turning the Power On/Off.....	7
Using the Menus.....	7
Video Input/Output Settings	8
Setting the Video Input/Output Format.....	8
Adjusting Output Video.....	9
Adjusting the Input Video.....	9
Changing Video Bus Assignments	10
Inputting Copy-Protected (HDCP) Video	10
Video Operations	11
Switching the Video	11
Compositing Video with Split (SPLIT)	17
Using a Visual Effect (VFX).....	18
Compositing Video with Picture-in-Picture (PinP)	19
Compositing Video with Downstream Keyer (DSK)	22
Using Imported Still Images.....	29
Saving a Still Image to a USB Flash Drive.....	31
Freezing Input Video (Freeze)	32
Applying a Fade to the Output Video (Output Fade).....	33
Audio Operations	34
Adjusting the Volume Level	34
Applying Effects to Input Audio	35
Applying Effects to Output Audio	36
Interlinking Audio Output to Video Switching (Audio Follow).....	37
Outputting AUX-bus Audio.....	38
Silencing Only Specific Audio (Mute)	39
Checking a Specific Audio Input (Solo).....	40
Other Features	41
Saving/Recalling Settings (Preset Memory)	41
Recording Multiple Operations to Automatically Execute (Macros).....	46
Combining Preset Memories and Macros for Operations (Sequencer)	53

Saving the Unit's Settings on a USB Flash Drive	59
Formatting USB Flash Drives	60
Using a Footswitch	61
Using an Expression Pedal	62
Assigning the Functions of the USER [1] [2] Buttons	63
Preventing Unintended Operation (Panel Lock).....	63
Controlling an External Recorder's Video Record Start/Stop from the V-8HD.....	64
Returning to the Factory Settings (Factory Reset)	64

Menu List	65
1: VIDEO INPUT	65
2: VIDEO OUTPUT.....	66
3: TRANSITION TIME	67
4: MIX/WIPE	67
5: SPLIT/VFX.....	68
6: PinP.....	71
7: DSK.....	74
8: AUDIO INPUT.....	75
9: AUDIO OUTPUT	76
10: AUDIO FOLLOW	77
11: PRESET MEMORY.....	78
12: MACRO	79
13: SEQUENCER.....	80
14: STILL IMAGE	81
15: FREEZE	81
16: AUTO SWITCHING	82
17: CTL/EXP	83
18: USB MEMORY	84
19: SYSTEM.....	85
List of Shortcut Keys	88

Appendix	89
Troubleshooting.....	89
Main Specifications	90
Dimensions	92
MIDI Implementation	93
MIDI Implementation Chart.....	108
VIDEO Block Diagram	109
AUDIO Block Diagram.....	110

Panel Descriptions

Top Panel / Side Panel

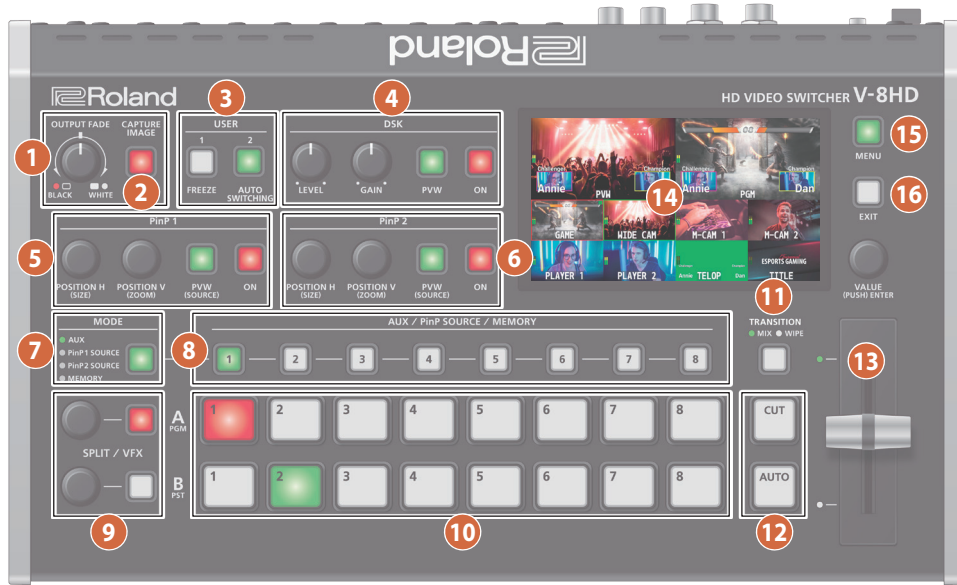

Name	Explanation						
1 [OUTPUT FADE] knob	The program output video and audio fade in/out. Turning the knob toward the left fades the output to black, and turning the knob toward the right fades the output to white. <table border="1"> <tr> <td>Lit</td> <td>Fade-out completed</td> </tr> <tr> <td>Blink</td> <td>Fading in/out</td> </tr> <tr> <td>Unlit</td> <td>Normal output</td> </tr> </table>	Lit	Fade-out completed	Blink	Fading in/out	Unlit	Normal output
Lit	Fade-out completed						
Blink	Fading in/out						
Unlit	Normal output						
2 [CAPTURE IMAGE] button	Captures a still image from the input/output video.						
3 USER							
[1], [2] buttons	Execute the functions that are assigned by the menu settings. With the factory settings, the following functions are assigned. <table border="1"> <tr> <td>[1]</td> <td>FREEZE: Stops (freezes) input video.</td> </tr> <tr> <td>[2]</td> <td>AUTO SWITCHING: Automatically switches the input video.</td> </tr> </table>	[1]	FREEZE: Stops (freezes) input video.	[2]	AUTO SWITCHING: Automatically switches the input video.		
[1]	FREEZE: Stops (freezes) input video.						
[2]	AUTO SWITCHING: Automatically switches the input video.						
4 DSK							
[LEVEL] knob	During DSK compositing, this adjusts the amount of keying (transparency).						
[GAIN] knob	During DSK compositing, this adjusts the degree of edge blur (the semi-transmissive region) for keying.						
[PVW] button	When this is on (lit), it makes the DSK compositing results the preview output.						
[ON] button	Switches DSK composition on or off. <table border="1"> <tr> <td>Lit</td> <td>DSK composition on</td> </tr> <tr> <td>Blink</td> <td>Currently switching video</td> </tr> <tr> <td>Unlit</td> <td>DSK composition off</td> </tr> </table>	Lit	DSK composition on	Blink	Currently switching video	Unlit	DSK composition off
Lit	DSK composition on						
Blink	Currently switching video						
Unlit	DSK composition off						

Name	Explanation												
5 PinP 1													
[POSITION H] knob	During PinP 1 compositing, this adjusts the horizontal display position of the inset screen.												
[POSITION V] knob	During PinP 1 compositing, this adjusts the vertical display position of the inset screen.												
[PVW] button	When this is on (lit), it makes the PinP 1 compositing results the preview output.												
[ON] button	Switches PinP 1 composition on or off. <table border="1"> <tr> <td>Lit</td> <td>PinP 1 composition on</td> </tr> <tr> <td>Blink</td> <td>Currently switching video</td> </tr> <tr> <td>Unlit</td> <td>DSK composition off</td> </tr> </table>	Lit	PinP 1 composition on	Blink	Currently switching video	Unlit	DSK composition off						
Lit	PinP 1 composition on												
Blink	Currently switching video												
Unlit	DSK composition off												
6 PinP 2													
[POSITION H] knob	During PinP 2 compositing, this adjusts the horizontal display position of the inset screen.												
[POSITION V] knob	During PinP 2 compositing, this adjusts the vertical display position of the inset screen.												
[PVW] button	When this is on (lit), it makes the PinP 2 compositing results the preview output.												
[ON] button	Switches PinP 2 composition on or off. <table border="1"> <tr> <td>Lit</td> <td>PinP 2 composition on</td> </tr> <tr> <td>Blink</td> <td>Currently switching video</td> </tr> <tr> <td>Unlit</td> <td>DSK composition off</td> </tr> </table>	Lit	PinP 2 composition on	Blink	Currently switching video	Unlit	DSK composition off						
Lit	PinP 2 composition on												
Blink	Currently switching video												
Unlit	DSK composition off												
7 MODE													
[MODE] button	Switches the functioning of the AUX / PinP SOURCE / MEMORY [1]–[8] buttons. The lit color of the button indicates the function that is selected. <table border="1"> <tr> <td rowspan="4">Pressing</td> <td>Green</td> <td>AUX</td> </tr> <tr> <td>Yellow</td> <td>PinP 1 SOURCE</td> </tr> <tr> <td>Magenta</td> <td>PinP 2 SOURCE</td> </tr> <tr> <td>Blue</td> <td>MEMORY</td> </tr> <tr> <td>Long-pressing</td> <td>Orange</td> <td>MACRO</td> </tr> </table>	Pressing	Green	AUX	Yellow	PinP 1 SOURCE	Magenta	PinP 2 SOURCE	Blue	MEMORY	Long-pressing	Orange	MACRO
Pressing	Green		AUX										
	Yellow		PinP 1 SOURCE										
	Magenta		PinP 2 SOURCE										
	Blue	MEMORY											
Long-pressing	Orange	MACRO											

Name	Explanation						
8 AUX / PinP SOURCE / MEMORY							
[1]–[8] buttons	Select the object of operation according to the function selected by the [MODE] button. The selected button lights up. The respective buttons also function as indicators showing the input status of the video. <table border="1"> <tr> <td>Lit white</td> <td>Valid video is being input.</td> </tr> <tr> <td>Blink white</td> <td>Video whose format differs from the system format setting is input.</td> </tr> <tr> <td>Unlit</td> <td>No video is input.</td> </tr> </table>	Lit white	Valid video is being input.	Blink white	Video whose format differs from the system format setting is input.	Unlit	No video is input.
Lit white	Valid video is being input.						
Blink white	Video whose format differs from the system format setting is input.						
Unlit	No video is input.						
[MODE] button	Explanation						
AUX	The buttons function as AUX-bus selection buttons. They select the video (channel 1–8) to send to the AUX bus.						
PinP 1 SOURCE	The buttons function as source screen select buttons for PinP 1. The buttons select the video (channels 1–8) that is shown in the inset screen of PinP 1.						
PinP 2 SOURCE	The buttons function as source screen select buttons for PinP 2. The buttons select the video (channels 1–8) that is shown in the inset screen of PinP 2.						
MEMORY	The buttons function as preset-memory selection buttons. These save video and audio settings, the state of the operation panel, and other current settings, and call up settings saved in memory. Press this button to recall settings; long-press this button to save settings.						
MACRO	The buttons function as macro selection buttons. Executes a macro (a series of recorded operations).						

9 SPLIT / VFX A, SPLIT / VFX B	
SPLIT/VFX [A] knob	Adjust the depth of the effect when split/visual effect A is on.
SPLIT/VFX [B] knob	Adjust the depth of the effect when split/visual effect B is on.
* By holding down the SPLIT/VFX button and turning the SPLIT/VFX knob, you can change the type of split/visual effect.	
SPLIT/VFX [A] button	If this is on (lit), the effect of split/visual effect A is applied to the video selected by the Cross-point A [1]–[8] buttons.
SPLIT/VFX [B] button	If this is on (lit), the effect of split/visual effect B is applied to the video selected by the Cross-point B [1]–[8] buttons.
* If the SPLIT/VFX type is set to split, it is not possible to turn both A and B on.	

10 A/PGM, B/PST	
Cross-point A [1]–[8] buttons	Selects the video to input to bus A of the video mixer. The selected button lights up. When the SPLIT/VFX [A] button is on, the split/visual effect A effect is applied to the video.
Cross-point B [1]–[8] buttons	Selects the video to input to bus B of the video mixer. The selected button lights up. * While compositing of the video is in progress it lit red. When the SPLIT/VFX [B] button is on, the split/visual effect B effect is applied to the video.

Name	Explanation				
11 [TRANSITION] button	Selects the video transition effects. <table border="1"> <tr> <td>MIX</td> <td>The two pictures are blended together as the video is switched.</td> </tr> <tr> <td>WIPE</td> <td>The original video is broken into by the next video.</td> </tr> </table>	MIX	The two pictures are blended together as the video is switched.	WIPE	The original video is broken into by the next video.
MIX	The two pictures are blended together as the video is switched.				
WIPE	The original video is broken into by the next video.				
12 [CUT] button [AUTO] button	These make the preset video (the video to output next) the final output. <table border="1"> <tr> <td>[CUT]</td> <td>The picture switches instantly.</td> </tr> <tr> <td>[AUTO]</td> <td>The picture switches with a transition effect applied.</td> </tr> </table>	[CUT]	The picture switches instantly.	[AUTO]	The picture switches with a transition effect applied.
[CUT]	The picture switches instantly.				
[AUTO]	The picture switches with a transition effect applied.				
13 Video fader	Manually switch between the videos being input to bus A and B, and send them to the program output.				
Transition indicators	The indicator for the final-output bus end lights up.				
14 Monitor	Shows the input/output video, a still image, or a menu screen.				
15 [MENU] button	Switches between displaying or hiding the menu. The menu appears on the built-in monitor and the display connected to the OUTPUT 3 connector.				
16 [EXIT] button	Returns you to the menu one level higher.				
17 [VALUE] knob	<table border="1"> <tr> <td>Turning</td> <td>Selects a menu item or changes a setting value.</td> </tr> <tr> <td>Pressing</td> <td>Accepts the selected menu item or applies changes to a setting. It also executes operations.</td> </tr> </table>	Turning	Selects a menu item or changes a setting value.	Pressing	Accepts the selected menu item or applies changes to a setting. It also executes operations.
Turning	Selects a menu item or changes a setting value.				
Pressing	Accepts the selected menu item or applies changes to a setting. It also executes operations.				

Side panel

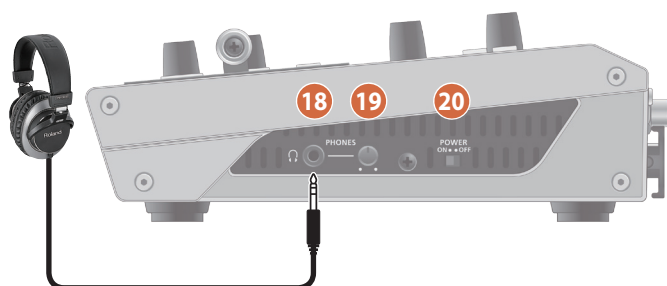

Name	Explanation
18 PHONES jack (Stereo miniature type)	Connect headphones here.
19 [PHONES] knob	Adjusts the volume of the headphones.
20 [POWER] switch	Turns the power on/off.

Rear Panel (Connecting Your Equipment)

- * To prevent malfunction and equipment failure, always turn down the volume, and turn off all the units before making any connections.
- * Be sure to use cables and adaptor plugs with the proper connectors matching those of the other devices you are using.

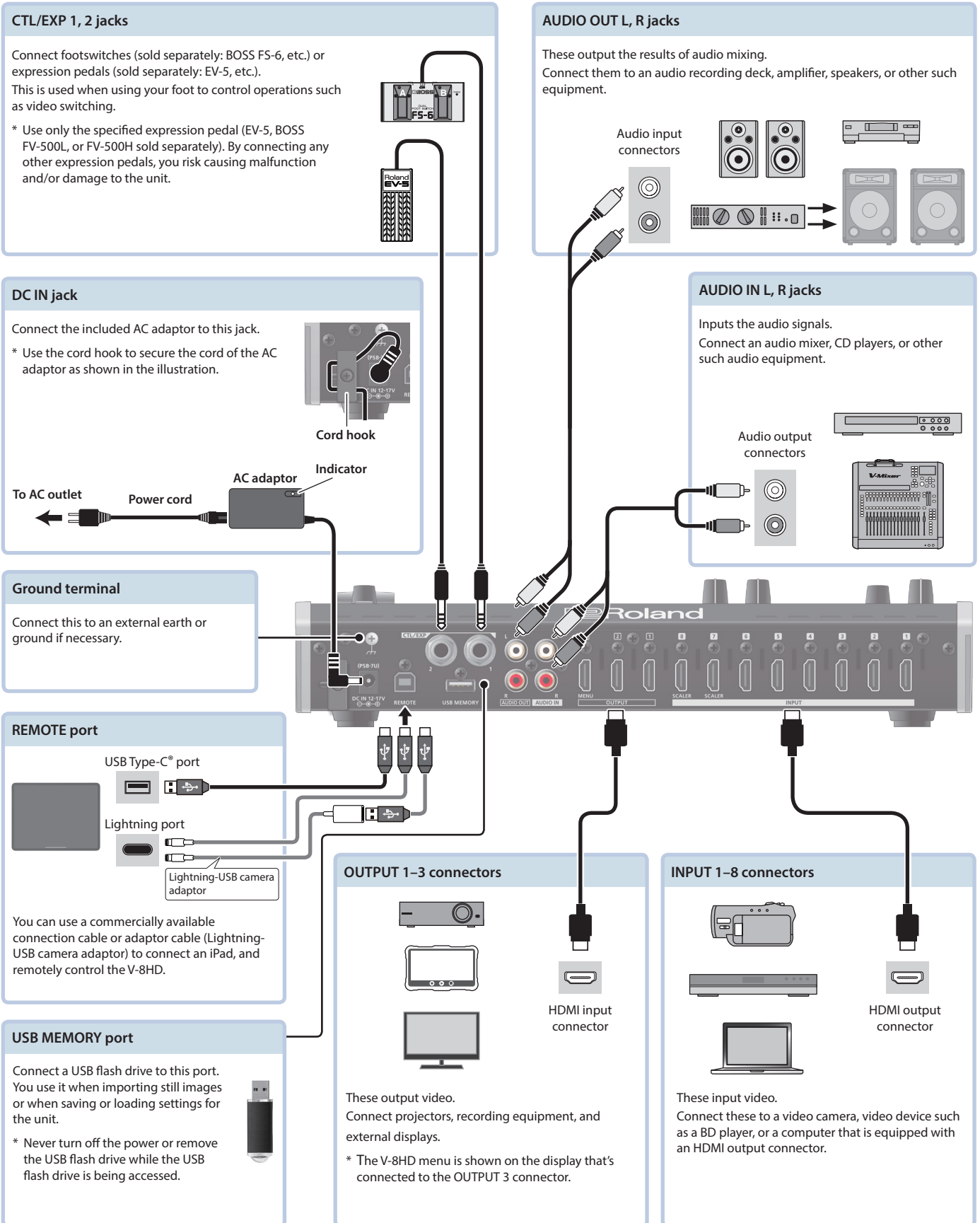

Connecting a Footswitch

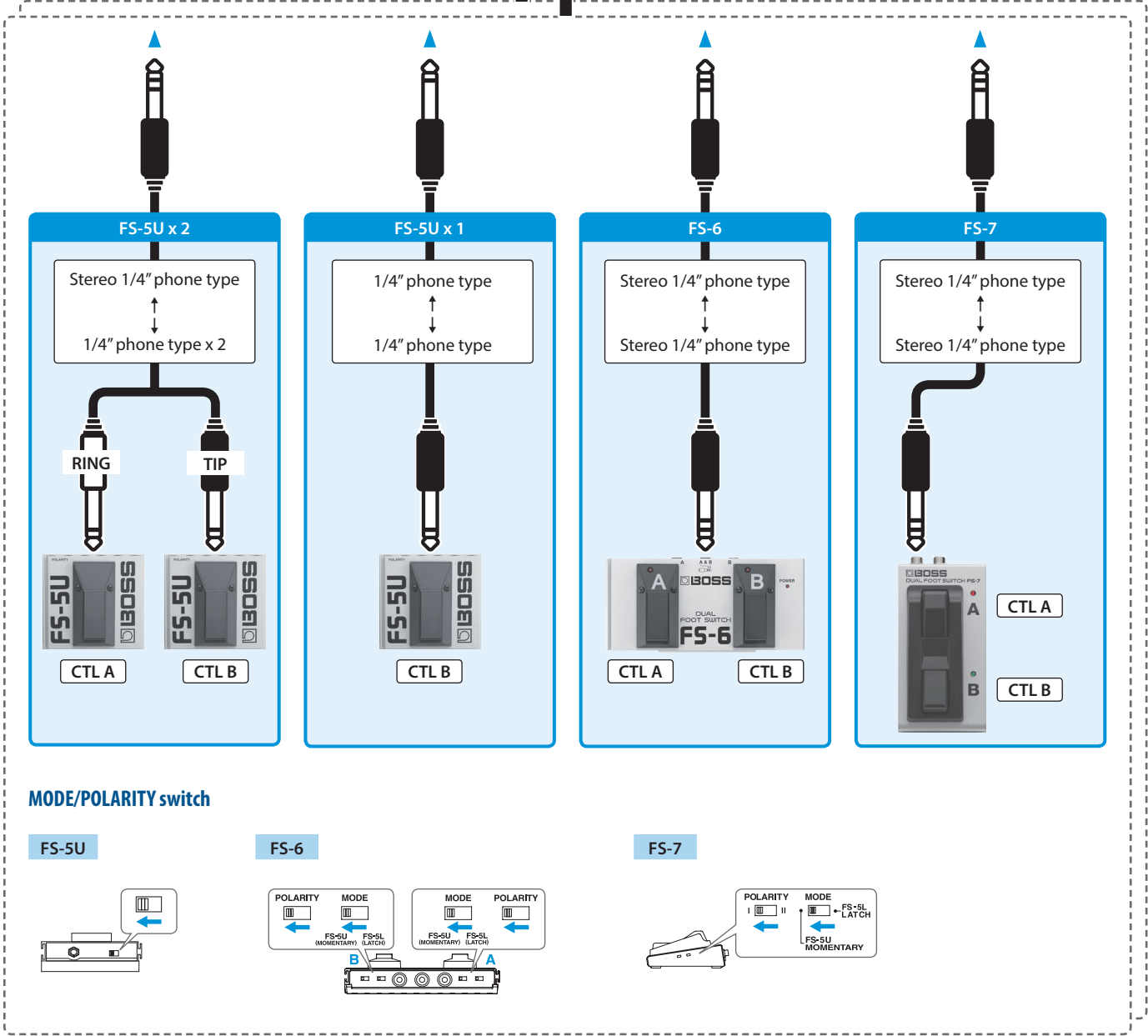
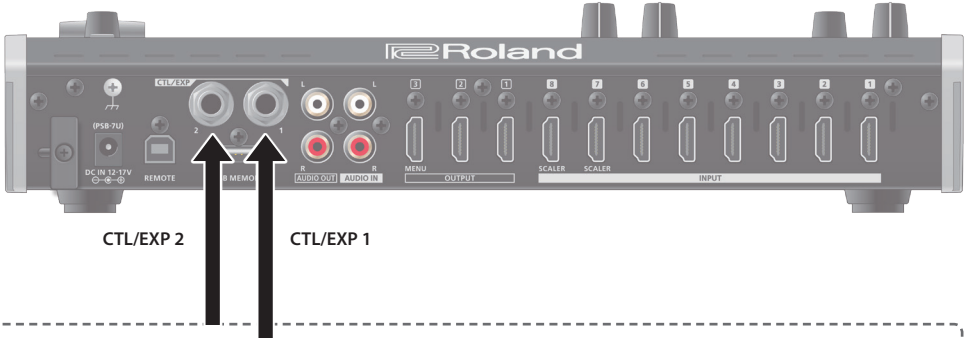

NOTE
 The BOSS FS-6's A, B, and A&B jacks also act as the power switch. The power turns on when you insert a plug into the jack, and turns off when you remove the plug.
 To prevent the batteries from running down, remove the plugs from the jacks when you're not using the BOSS FS-6.

Multi-View Monitor Display

This unit's monitor shows a list of the input/output video (final output, preview output, input channels 1–8), a level meter, and a menu. If you press the [MENU] button, the menu is shown overlaid on the multi-view.



No.	Name	Explanation						
1	PVW (preview) section	Displays the preset video (the video to be output next).						
2	PGM (program) section	Displays the final output video.						
3	Channel section	Displays video input via channels 1–8. The final video output and preset video (the video to be output next) are displayed with tally frames.						
		<p>Channel information</p> <p>When the multi-view monitor is shown on an external display, an "MT" indication is shown when the audio mute function (p. 39) is on.</p> <p>When the audio follow function (p. 37) is on, an "A.F." indication is shown.</p> <p>* This is not shown on this unit's display.</p>						
		<p>1 Displays a audio level meter. * The indicators for the level meter are the same as for AUDIO OUT.</p> <p>2 Indicates the function selected by the [MODE] button.</p> <table border="1"> <thead> <tr> <th>Indicator</th> <th>Explanation</th> </tr> </thead> <tbody> <tr> <td>Green</td> <td>AUX (AUX bus selected)</td> </tr> <tr> <td>Yellow</td> <td>PinP 1 SOURCE (PinP 1 source screen selected)</td> </tr> <tr> <td>Magenta</td> <td>PinP 2 SOURCE (PinP 2 source screen selected)</td> </tr> </tbody> </table> <p>3 The REC indicator is shown. If a camera that supports the HDMI REC TRIGGER function is connected, this is shown when the camera's REC button is pressed.</p>	Indicator	Explanation	Green	AUX (AUX bus selected)	Yellow	PinP 1 SOURCE (PinP 1 source screen selected)
Indicator	Explanation							
Green	AUX (AUX bus selected)							
Yellow	PinP 1 SOURCE (PinP 1 source screen selected)							
Magenta	PinP 2 SOURCE (PinP 2 source screen selected)							
4	AUDIO IN level meter	The audio level meter for AUDIO IN is shown above or below. * The indicators for the level meter are the same as for AUDIO OUT.						

MEMO

- In the SYSTEM menu, you can specify whether the "label name", "tally frame", "audio level meter", "AUX indicator", "PinP indicator", and "REC indicator" are visible or hidden.
 - MULTI-VIEW LABEL (label names) – AUX/PinP INDICATOR (AUX indicator/PinP indicator)
 - TALLY FRAME – REC INDICATOR
 - AUDIO LEVEL METER
 - AUDIO IN (AUDIO IN level meter)
- You can edit the label name. Use the SYSTEM menu item "MULTI-VIEW LABEL EDIT" to edit the label name.
- For details on the cameras that support the REC indicator function, refer to the Roland website.

<https://proav.roland.com/>

Turning the Power On/Off

* Before turning the unit on/off, always be sure to turn the volume down. Even with the volume turned down, you might hear some sound when switching the unit on/off. However, this is normal and does not indicate a malfunction.

Turning the power on

1. Make sure all devices are turned off.
2. Turn on the [POWER] switch on the V-8HD to turn on the power.

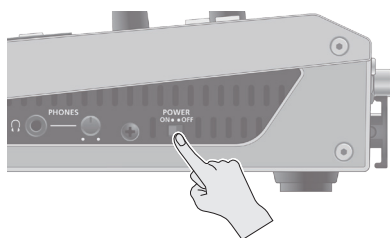

3. Turn on the power to the source devices.
Turn on the power to video cameras or other source equipment connected to input connectors on the V-8HD.
4. Turn on the power to the output devices.
Turn on the power to projectors or other devices connected to output connectors on the V-8HD.

Turning the power off

1. Turn off the power in the sequence of first the output equipment, and then the sources.
2. Turn off the [POWER] switch on the V-8HD to turn off the power.

About the Auto Off function

The power to the V-8HD turns off automatically when all of the following states persist for 240 minutes (Auto Off function).

- No operation performed on the V-8HD
- No audio or video input
- No equipment is connected to the OUTPUT connectors

If you do not want the power to be turned off automatically, disengage the Auto Off function. Press the [MENU] button → "SYSTEM" → set "AUTO OFF" to "OFF".

* Unsaved data is lost when the power turns off. Before turning the power off, save the data that you want to keep.

* To restore power, turn the power on again.

Using the Menu

This explains how to display menus and make settings for video and for the V-8HD itself.

* The menu is also appears on the display connected to the OUTPUT 3 connector.

1. Press the [MENU] button to display the menu.

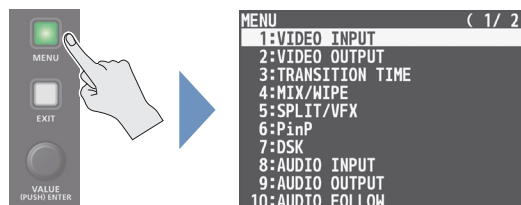

The [MENU] button lights up, the menu categories are displayed.

2. Turn the [VALUE] knob to select a category, and press the [VALUE] knob to confirm.

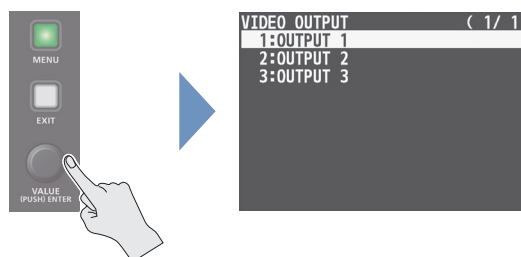

The menu for the selected category is displayed.

3. Turn the [VALUE] knob to select a menu item, then press the [VALUE] knob to confirm.

The cursor moves to the setting value.

- If the menu item is located at a deeper level, repeat step 3.
- Pressing the [EXIT] button moves you back one level higher.

4. Turn the [VALUE] knob to change the value of the setting.

• By turning the [VALUE] knob while pressing it, you can change the value more greatly.

• Pressing and holding the [VALUE] knob returns the current menu item you're setting to its default value.

5. Press the [VALUE] knob to apply the setting.

The cursor returns to the menu item.

6. Press the [MENU] button to quit the menu.

Video Input/Output Settings

Setting the Video Input/Output Format

Set parameters for the input/output format to match the connected equipment.

Setting the System Format

On the V-8HD, the input/output format is determined according to the system format. You set the input/output format to match the connected equipment.

System format	Input format (*1)	Output format (*2)
	INPUT 1-6 connectors	OUTPUT 1-2 connectors
1080p	1080p, 1080i	1080p
1080i	1080p, 1080i	1080i
720p	720p	720p

(*1) You can specify separate individual input formats for the channel 7 and 8 input connectors, regardless of the system format.

For details, refer to "Setting the Input Formats for Channels 7 and 8" on this page.

(*2) The output format at the OUTPUT 3 connector is fixed at "1080p".

1. Press the [MENU] button → "SYSTEM" → select "SYSTEM FORMAT", and press the [VALUE] knob.

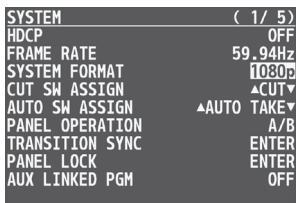

2. Use the [VALUE] knob to set the system format to "1080p", "1080i", or "720p", and press the [VALUE] knob.
3. Press the [MENU] button to quit the menu.

Internal processing

The V-8HD's internal processing is progressive. Interlaced input video is automatically converted to a progressive signal.

The picture might appear jagged at this time, or the picture in a PinP inset screen or on the multi-view monitor might waver.

This is due to progressive conversion, and is not a malfunction.

About frame rates

To change the V-8HD's frame rate, press the [MENU] button → "SYSTEM" → "FRAME RATE".

Setting the Input Formats for Channels 7 and 8

By factory default, the EDID assignment for channels 7 and 8 is "INTERNAL" (set so that EDID values of all inputtable formats are sent).

To specify an input format of your choice, change the setting of the EDID information being sent so that it matches the incoming video signal.

1. Press the [MENU] button → "VIDEO INPUT" → select "INPUT 7 (SCALER)" or "INPUT 8 (SCALER)", and press the [VALUE] knob.

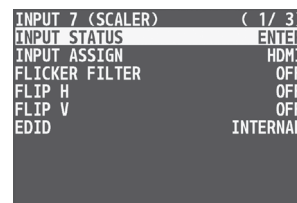

2. Use the [VALUE] knob to select "EDID", and press the [VALUE] knob.

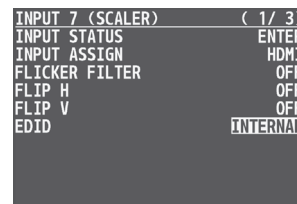

3. Use the [VALUE] knob to set the input format (the EDID information to send), and press the [VALUE] knob.

Value	
INTERNAL	EDID information for all inputtable formats is sent.
SVGA (800x600)	UXGA (1600x1200)
XGA (1024x768)	WUXGA (1920x1200)
WXGA (1280x800)	720p
FWXGA (1366x768)	1080i
SXGA (1280x1024)	1080p
SXGA+ (1400x1050)	

4. Press the [MENU] button to quit the menu.

Adjusting Output Video

Here's how to adjust the output image appropriately for the device that's receiving the V-8HD's output.

MEMO

You can output a test pattern, useful for adjusting the image quality of a display.

You use the [MENU] button → "SYSTEM" → "TEST PATTERN" to specify the test pattern.

1. Press the [MENU] button → "VIDEO OUTPUT" → select one of "OUTPUT 1" to "OUTPUT 3", and press the [VALUE] knob.

A menu for the selected output video appears.

```

OUTPUT 1 ( 1 / 1 )
OUTPUT STATUS CONNECTED
OUTPUT ASSIGN PROGRAM
COLOR SPACE YPbPr 4:4:4
DVI-D/HDMI SIGNAL HDMI
BRIGHTNESS 0
CONTRAST 0
SATURATION 0
RED 0
GREEN 0
BLUE 0
    
```

2. Select a menu item, then turn the [VALUE] knob to adjust the output video, and press the [VALUE] knob.

```

OUTPUT 1 ( 1 / 1 )
OUTPUT STATUS NOT CONNECTED
OUTPUT ASSIGN PROGRAM
COLOR SPACE YPbPr 4:4:4
DVI-D/HDMI SIGNAL HDMI
BRIGHTNESS 2
CONTRAST 0
SATURATION 0
RED 0
GREEN 0
BLUE 0
    
```

Menu item	Explanation
OUTPUT STATUS	Displays information about the output connector.
OUTPUT ASSIGN	Specifies the video bus that is assigned to the OUTPUT connector.
COLOR SPACE	Specifies the color space (system for representing colors in video).
DVI-D/HDMI SIGNAL	Specifies the output mode for HDMI output.
BRIGHTNESS	Adjusts the brightness.
CONTRAST	Adjusts the contrast.
SATURATION	Adjusts the saturation.
RED	Adjusts the red level.
GREEN	Adjusts the green level.
BLUE	Adjusts the blue level.

3. Press the [MENU] button to quit the menu.

Adjusting the Input Video

Here's how to adjust the character of the video that's input to INPUT 1-8.

For INPUT 7 and 8 connectors, you can also adjust the scaling.

1. Press the [MENU] button → "VIDEO INPUT" → select one of "INPUT 1" to "INPUT 8 (SCALER)", and press the [VALUE] knob.

A menu for the selected input video appears.

```

INPUT 1 ( 1 / 1 )
INPUT STATUS ENTER
INPUT ASSIGN HDMI
FLIP H OFF
FLIP V OFF
BRIGHTNESS 0
CONTRAST 0
SATURATION 0
    
```

2. Select a menu item, then turn the [VALUE] knob to adjust the input video, and press the [VALUE] knob.

```

INPUT 1 ( 1 / 1 )
INPUT STATUS ENTER
INPUT ASSIGN HDMI
FLIP H OFF
FLIP V OFF
BRIGHTNESS 3
CONTRAST 0
SATURATION 0
    
```

Menu item	Explanation
INPUT 1-8	
INPUT STATUS	Displays information about the input video.
INPUT ASSIGN	Selects the input source.
FLIP H	If this is "ON", the video is input with left and right flipped.
FLIP V	If this is "ON", the video is input with top and bottom flipped.
BRIGHTNESS	Adjusts the brightness.
CONTRAST	Adjusts the contrast.
SATURATION	Adjusts the saturation.

```

INPUT 7 (SCALER) ( 2 / 3 )
ZOOM 100.0%
SCALING TYPE FULL
-MANUAL SIZE H ---
-MANUAL SIZE V ---
POSITION H 0
POSITION V 0
    
```

```

INPUT 7 (SCALER) ( 3 / 3 )
BRIGHTNESS 0
CONTRAST 0
SATURATION 0
RED 0
GREEN 0
BLUE 0
    
```

INPUT 7, 8	
FLICKER FILTER	If this is "ON", flickering is reduced.
EDID	Specifies the input format (EDID).
ZOOM	Adjusts the zoom ratio.
SCALING TYPE	Specifies the scaling type.
MANUAL SIZE H	Adjusts the horizontal size when scaling type is set to "MANUAL".
MANUAL SIZE V	Adjusts the vertical size when scaling type is set to "MANUAL".
POSITION H	Adjusts the display position in the horizontal direction.
POSITION V	Adjusts the display position in the vertical direction.
RED	Adjusts the red level.
GREEN	Adjusts the green level.
BLUE	Adjusts the blue level.

3. Press the [MENU] button to quit the menu.

Changing Video Bus Assignments

The V-8HD has four internal video buses (PROGRAM, PREVIEW, AUX, and MULTI-VIEW).

You can select which buses to output via the OUTPUT 1–3 connectors.

1. Press the [MENU] button → “VIDEO OUTPUT” → select one of “OUTPUT 1” to “OUTPUT 3”, and press the [VALUE] knob.

A menu for the selected output video appears.

OUTPUT 1	(1 / 1)
OUTPUT STATUS	CONNECTED
OUTPUT ASSIGN	PROGRAM
COLOR SPACE	YpPr 4:4:4
DVI-D/HDMI SIGNAL	HDMI
BRIGHTNESS	0
CONTRAST	0
SATURATION	0
RED	0
GREEN	0
BLUE	0
REC CONTROL	ON

2. Use the [VALUE] knob to select “OUTPUT ASSIGN”, and press the [VALUE] knob.

OUTPUT 1	(1 / 1)
OUTPUT STATUS	CONNECTED
OUTPUT ASSIGN	PROGRAM
COLOR SPACE	YpPr 4:4:4
DVI-D/HDMI SIGNAL	HDMI
BRIGHTNESS	0
CONTRAST	0
SATURATION	0
RED	0
GREEN	0
BLUE	0
REC CONTROL	ON

3. Use the [VALUE] knob to select the video bus, and press the [VALUE] knob.

* If a connector other than the OUTPUT 3 connector is set to “MULTI-VIEW”, the audio meter, label, and menu etc. are not shown.

4. Press the [MENU] button to quit the menu.

MEMO

- By holding down the [EXIT] button and pressing the [TRANSITION] button, you can switch the video bus that assign to OUTPUT 3 connector.
- For details about video transitions on the A/PGM bus and B/PST bus, refer to “Switching the Video” (p. 11).
- For details about video transitions on the AUX bus, refer to “Switching AUX Output” (p. 16).

About audio outputs assigned to video buses

Changing an video bus assignment makes the output audio also change in tandem, according to the assigned bus.

Video bus assignment	Output audio
PROGRAM	Outputs the audio of the MASTER OUTPUT bus.
PREVIEW	
MULTI-VIEW	
AUX	Outputs the audio of the AUX bus.

You can also fix the output audio to the MASTER OUTPUT bus or AUX bus regardless of the video bus assignment (p. 38).

Inputting Copy-Protected (HDCP) Video

If you want to input HDCP-protected video from a BD player or other device, you can enable HDCP input.

- * If you want to output HDCP-protected video, connect an HDCP-capable display.

What's HDCP?

HDCP is copyright-protection technology that prevents unlawful copying of content by encoding the path when sending digital signals from a video playback device to a display monitor or other display equipment.

1. Press the [MENU] button → “SYSTEM” → select “HDCP”, and press the [VALUE] knob.

SYSTEM	(1 / 4)
HDCP	OFF
FRAME RATE	59.94Hz
SYSTEM FORMAT	1080p
CUT SW ASSIGN	▲CUT▼
AUTO SW ASSIGN	▲AUTO TAKE▼
PANEL OPERATION	A/B
EFFECTS TRANSITION SYNC	OFF
PANEL LOCK	ENTER
AUX LINKED PGM	OFF

2. Use the [VALUE] knob to select “ON”, and press the [VALUE] knob.

Value	Explanation
ON	HDCP-protected video can be input. HDCP is applied to the output video.
OFF	HDCP-protected video cannot be input.

4. Press the [MENU] button to quit the menu.

Video Operations

Switching the Video

Here's how to switch between input video while applying an effect, and final output.

About the operation mode for video transitions

There are two operation modes for switching the video on the PGM/A bus and PST/B bus: the "PGM/PST mode" and the "A/B mode".

* With the factory settings, the operation mode is set to A/B mode.

Mode	Explanation
A/B	When the video fader is operated, the video at the bus position toward which the video fader is flipped always becomes the final output.
	When the [CUT] or [AUTO] button is operated, the video on the A bus and the video on the B bus become the final output in alternation.
PGM/PST	The video on the PGM bus is always the final output.
	The video on the PST bus is preset video (the video to be output next).
	Operating the video fader or the [CUT] or [AUTO] button makes the final video output and the preset video change places.

Setting the Operation Mode

1. Press the [MENU] button → "SYSTEM" → select "PANEL OPERATION", and press the [VALUE] knob.

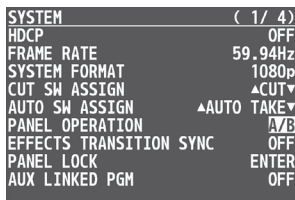

2. Use the [VALUE] knob to select "A/B" or "PGM/PST", and press the [VALUE] knob.
3. Press the [MENU] button to quit the menu.

Using Mix/Wipe to Switch Video

When A/B mode

The video at the end to which the video fader is flipped is always the final output.

1. Flip the video fader all the way upward or downward.

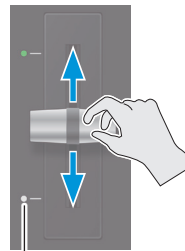

Transition indicators

2. Press a Cross-point [1]–[8] button at the end to which the video fader is not flipped to select the preset video (the video to output next).

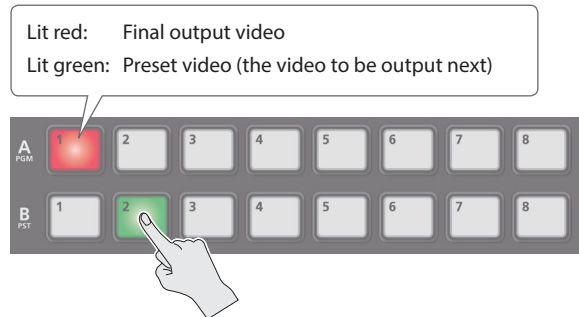

The preset video appears in the PVW section of the monitor.

3. Press the [TRANSITION] button to select the transition effect.



The MIX or WIPE indicator is lit.

Mode	Explanation
MIX	The two pictures are blended together as the video is switched. A ► B ► B
WIPE	The original video is broken into by the next video. A ► A ► B

4. Move the video fader in the direction opposite to the direction in step 1.

The video changes.

When PGM/PST mode is selected

1. Flip the video fader all the way upward or downward.

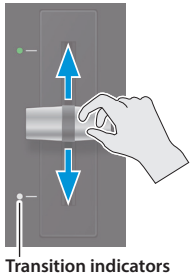

2. Press the [TRANSITION] button to select the transition effect.



3. Press a Cross-point B [1]–[8] button to select the preset video (the video to be output next).

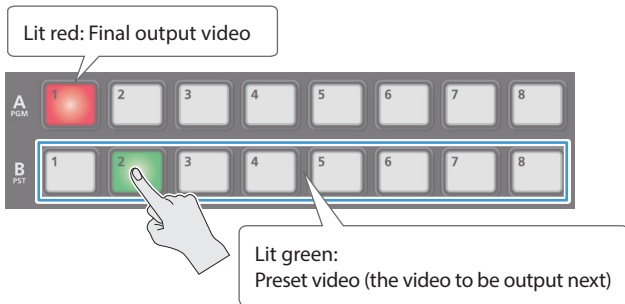

4. Move the video fader in the direction opposite to the direction in step 1.

The video changes.

When the video has switched completely, the illuminated state of the A [1]–[8] buttons and B [1]–[8] buttons is exchanged.

Changing the mix/wipe pattern

You can use the MIX/WIPE menu to specify the pattern by which the mix/wipe occurs and the direction of the wipe.

1. Press the [MENU] button → select “MIX/WIPE”, and press the [VALUE] knob.

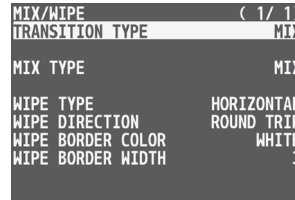

2. Use the [VALUE] knob to select a menu item, and press the [VALUE] knob.

Menu item	Explanation
MIX TYPE	Specifies the transition pattern for mix.
WIPE TYPE	Specifies the transition pattern for wipe.
WIPE DIRECTION	Specifies the direction of wipe.
WIPE BORDER COLOR	Specifies the color of the border added to the edge of the wipe area.
WIPE BORDER WIDTH	Exchanges the colors.

3. Use the [VALUE] knob to change the value, and press the [VALUE] knob.

For details about these values, refer to p. 67.

4. Press the [MENU] button to quit the menu.

MEMO

- By holding down the [TRANSITION] button and pressing the [MENU] button, the MIX/WIPE menu appears.
- You can change the settings of the MIX/WIPE menu by holding down the [TRANSITION] button and turning the SPLIT/VFX [A] or [B] knob.

– When mix is selected

Operation	Explanation
[TRANSITION] button + turn the SPLIT/VFX [A] knob	MIX TYPE

– When wipe is selected

Operation	Explanation
[TRANSITION] button + turn the SPLIT/VFX [A] knob	WIPE TYPE
[TRANSITION] button + turn the SPLIT/VFX [B] knob	WIPE DIRECTION
[TRANSITION] button + turn while pressing the SPLIT/VFX [A] knob	WIPE BORDER COLOR
[TRANSITION] button + turn while pressing the SPLIT/VFX [B] knob	WIPE BORDER WIDTH

Using the [AUTO] or [CUT] Button to Switch Video

You can use the [AUTO] or [CUT] button to switch video, without using the video fader.

* You can perform operations using the [AUTO] and [CUT] buttons both in the PGM/PST mode and in the A/B mode.

1. Press the [AUTO] or [CUT] button at the desired timing for switching the video.

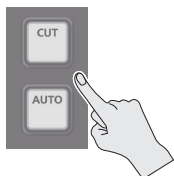

Button	Explanation
[CUT]	The picture switches instantly.
[AUTO]	A transition effect is applied and the video is switched automatically. The [AUTO] button flashes while the video transition is in progress.

MEMO

When you use the [AUTO] or [CUT] button to switch video, the actual output might come to differ from the position of the video fader.

Operating the video fader while in this state yields no change in output until the position of the video fader matches the actual output.

Changing the functions of the [CUT] and [AUTO] buttons

* In PGM/PST mode, the functions of the [CUT] and [AUTO] buttons are fixed.

1. Press the [MENU] button → "SYSTEM" → select "CUT SW ASSIGN" or "AUTO SW ASSIGN", and press the [VALUE] knob.

```

SYSTEM ( 1 / 4 )
HDCP OFF
FRAME RATE 59.94Hz
SYSTEM FORMAT 1080p
CUT SW ASSIGN ▲CUT▼
AUTO SW ASSIGN ▲AUTO TAKE▼
PANEL OPERATION A/B
EFFECTS TRANSITION SYNC OFF
PANEL LOCK ENTER
AUX LINKED PGM OFF
    
```

2. Use the [VALUE] knob to select a function of the button, and press the [VALUE] knob.

Function	Explanation
▲ AUTO TAKE ▼	Switches the video between A/PGM bus and B/PST bus.
▲ CUT ▼	Switches the video between A/PGM bus and B/PST bus as a cut.
CUT SW ASSIGN	
▲ AUTO TAKE	When the video of the B/PST bus is selected, switches to the video of the A/PGM bus.
▲ CUT	When the video of the B/PST bus is selected, switches to the video of the A/PGM bus as a cut.
▲ TRANSFORM	Switches to the video of the A/PGM bus as a cut only while you hold down the button.

Function	Explanation
AUTO SW ASSIGN	
AUTO TAKE ▼	When the video of the A/PGM bus is selected, switches to the video of the B/PST bus.
CUT ▼	When the video of the A/PGM bus is selected, switches to the video of the B/PST bus as a cut.
TRANSFORM ▼	Switches to the video of the B/PST bus as a cut only while you hold down the button.

3. Press the [MENU] button to quit the menu.

Turning PinP/DSK composition on/off in tandem with video transitions

You can make PinP composition (p. 19) or DSK composition (p. 22) turn on/off in tandem with the video transitions.

1. Press the [MENU] button → select "SYSTEM" → "EFFECTS TRANSITION SYNC", and press the [VALUE] knob.

```

SYSTEM ( 1 / 4 )
HDCP OFF
FRAME RATE 59.94Hz
SYSTEM FORMAT 1080p
CUT SW ASSIGN ▲CUT▼
AUTO SW ASSIGN ▲AUTO TAKE▼
PANEL OPERATION A/B
EFFECTS TRANSITION SYNC OFF
    
```

2. Use the [VALUE] knob to select "ON", and press the [VALUE] knob.

3. Press the [MENU] button to quit the menu.

Switching the Video Automatically (Auto Switching)

The video of INPUT 1–8 or of preset memories can be switched automatically (the auto switching function). You can make operation easier by letting the video switch automatically.

Operation modes for auto switching

Auto switching provides three operation modes that you can select as appropriate for your situation: “input scan”, “preset memory scan”, and “BPM sync”.

Switching at a specified interval (Input scan)

This automatically switches the INPUT 1–8 video when a specified length of time elapses.

You can change the duration that each video is shown, and also switch randomly between videos.

This is convenient when you want to switch between video signals of multiple cameras, for example when live-streaming a singer-instrumentalist.

* Channels that have no video input are skipped.

Switching preset memories (Preset memory scan)

This automatically switches between preset memories 1–8.

The video and audio are switched according to the settings that are saved in each preset memory.

* Preset memories in which no settings have been saved are skipped.

Switching in synchronization with the BPM (BPM sync)

This automatically switches the video at specified BPM intervals.

This lets you create video transitions that are synchronized with the music, for example when live-streaming a DJ performance or a musical performance.

Turning the auto switching function on/off

1. Press the [AUTO SWITCHING] button to turn the auto switching function on (lit).

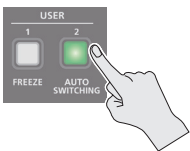

Indicator	Explanation
Green	Input scan
Blue	Preset memory scan
Red	BPM sync

2. To turn the auto switching function off, press the [AUTO SWITCHING] button once again.

Specifying the operation mode

Input scan

1. Press the [MENU] button → “AUTO SWITCHING” → select “TYPE”, and press the [VALUE] knob.

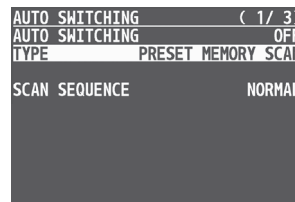

2. Use the [VALUE] knob to select “INPUT SCAN”, and press the [VALUE] knob.

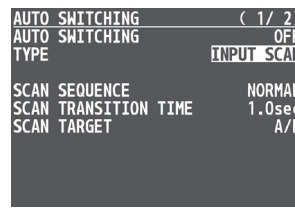

3. Use the [VALUE] knob to select a menu item, and press the [VALUE] knob.

Menu item	Explanation
SCAN SEQUENCE	Specifies the order in which video signals are shown. NORMAL: Switch in the order of INPUT 1 → 8. REVERSE: Switch in the order of INPUT 8 → 1. RANDOM: Switch randomly.
SCAN TRANSITION TIME	Specifies the video transition time.
SCAN TARGET	Specifies the video bus in which video transition. A/B: Switches between A/PGM bus and B/PST bus. PinP 1, PinP 2: Switches the video you want to make the inset screen of the PinP 1 or PinP 2.
INPUT 1–8 TIME	Specifies the time that the INPUT 1–8 video is shown.

4. Use the [VALUE] knob to change the value, and press the [VALUE] knob.
5. Press the [MENU] button to quit the menu.

Preset memory scan

1. Press the [MENU] button → "AUTO SWITCHING" → select "TYPE", and press the [VALUE] knob.

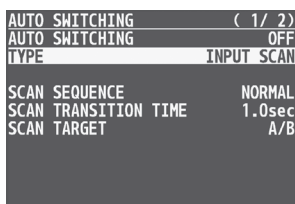

2. Use the [VALUE] knob to select "PRESET MEMORY SCAN", and press the [VALUE] knob.

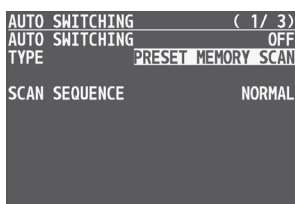

3. Use the [VALUE] knob to select a menu item, and press the [VALUE] knob.

Menu item	Explanation
SCAN SEQUENCE	Specifies the order in which preset memories are shown. NORMAL: Switch in the order of MEMORY 1 → 24. REVERSE: Switch in the order of MEMORY 24 → 1. RANDOM: Switch randomly.
MEMORY 1-24 TIME	Specifies the time that the MEMORY 1-24 video is shown.

4. Use the [VALUE] knob to change the value, and press the [VALUE] knob.
5. Press the [MENU] button to quit the menu.

BPM sync

1. Press the [MENU] button → "AUTO SWITCHING" → select "TYPE", and press the [VALUE] knob.

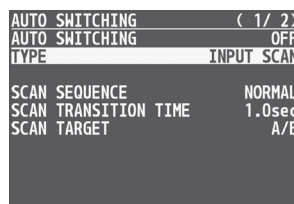

2. Use the [VALUE] knob to select "BPM SYNC", and press the [VALUE] knob.

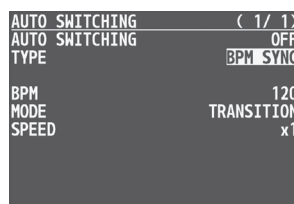

3. Use the [VALUE] knob to select a menu item, and press the [VALUE] knob.

Menu item	Explanation
BPM	Specifies the BPM.
MODE	Specifies how the picture is switched. TRANSITION: The picture switches using the currently selected transition effect (mix or wipe). CUT: The picture switches instantly.
SPEED	Specifies the picture switching speed as a multiple of the specified BPM.

4. Use the [VALUE] knob to change the value, and press the [VALUE] knob.
5. Press the [MENU] button to quit the menu.

Switching AUX Output

You can use button operations to directly select the video to send to the AUX bus.

1. Use the [MODE] button to select "AUX".

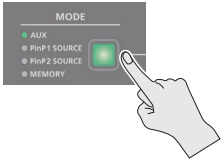

The AUX/PinP SOURCE/MEMORY [1]–[8] buttons function as AUX-bus selection buttons.

2. Press an AUX [1]–[8] button to select the AUX-bus video.

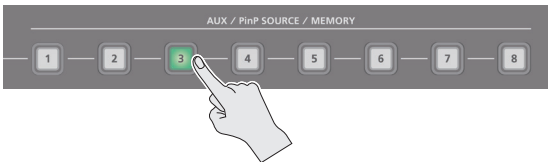

The AUX output is switched.

MEMO

- The display shows a green square (AUX indicator) for the input channel that is being sent to the AUX bus.
- For details on adjusting the volume of the AUX bus audio, refer to "Adjusting the output volume of the AUX bus" (p. 34).
- If the DSK mode is set to "alpha key" (p. 27) or "external key" (p. 28), the same video that's sent to the PGM bus is also sent to the AUX bus.
 - * This disables the AUX [1]–[8] button selection (the buttons go dark).

The colors of lighted AUX [1]–[8] buttons

When the [MODE] button is lighted in green, the AUX [1]–[8] buttons also function as indicators showing the status of video input.

Button	Explanation
Lit white	Valid video is being input.
Blink white	Video whose format differs from the system format setting is input.
Unlit	No video is input.

Sending the same video as the PGM output to the AUX output

By using the AUX link function, you can send the same video as the PGM bus (the final output video) to the AUX bus.

1. Press the [MENU] button → "SYSTEM" → select "AUX LINKED PGM", and press the [VALUE] knob.

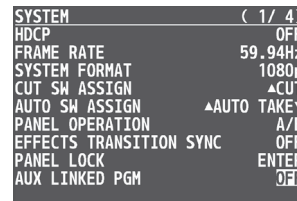

2. Use the [VALUE] knob to select "AUTO LINK" or "MANUAL LINK", and press the [VALUE] knob.

If you're not using the AUX link function, turn this "OFF".

3. Press the [MENU] button to quit the menu.

Selecting the AUX output

In the case of "OFF"

Press an AUX [1]–[8] button to select the video of the AUX bus.

In the case of "AUTO LINK" or "MANUAL LINK"

AUX link is enabled, and the same video as the PGM bus is sent to the AUX bus.

Temporarily disabling AUX link

When you press an AUX [1]–[8] button, the selection of the AUX [1]–[8] button is enabled (lit green).

Re-enabling AUX link

AUTO LINK	When you operate the [AUTO] button etc. to switch the video of the PGM bus, AUX link is automatically enabled.
MANUAL LINK	When you press the AUX/MEMORY button that is currently selected (lit green), AUX link is enabled.

Compositing Video with Split (SPLIT)

This composites two video streams in a split screen. The final output video is displayed above or on the left, and the preset video (the video to be output next) is displayed below or on the right.

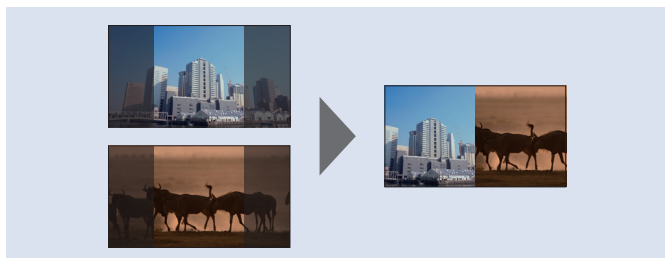

Specifying a Split Composition Pattern

This makes the settings for the split composition pattern to match the video you want to composite.

1. Press the [MENU] button → "SPLIT/VFX" → select "SPLIT/VFX A" or "SPLIT/VFX B", and press the [VALUE] knob.

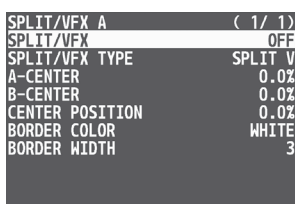

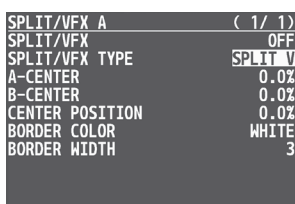

2. Use the [VALUE] knob to select "SPLIT/VFX TYPE", and press the [VALUE] knob.



3. Use the [VALUE] knob to select the SPLIT type, and press the [VALUE] knob.

You can select "SPLIT V" or "SPLIT H".

Value	Explanation
SPLIT V	This vertically crops the center section of the video. 
SPLIT H	This horizontally crops the center section of the video. 

4. Press the [MENU] button to quit the menu.

MEMO

For each of the split screens, you can adjust the displayed position of the video and change the color or width of the border. For details, refer to p. 68 of "Menu list".

Compositing Using Split

1. Press a Cross-point A [1]–[8] button to select the video you want to display above or on the left.

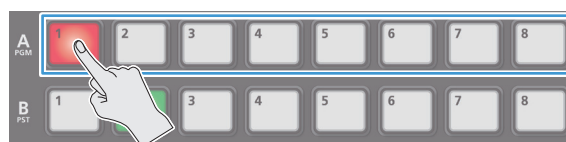

2. Press a Cross-point B [1]–[8] button to select the video you want to display below or on the right.

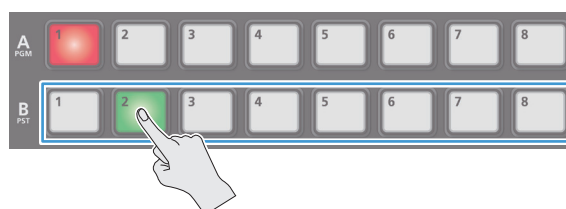

3. Press the SPLIT/VFX [A] or [B] button to turn on SPLIT (lighted).

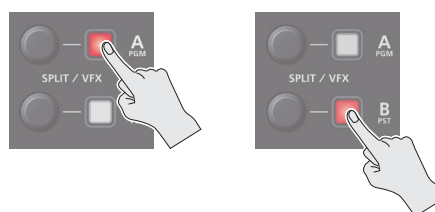

The video you selected in steps 1 and 2 is composited.

4. Use the SPLIT/VFX [A] or [B] knob to adjust the display position of the video.

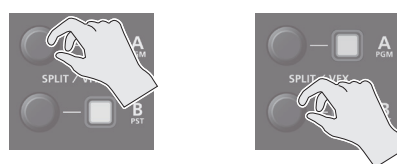

- By turning the knob while pressing it, you can adjust the position of the dividing line between the two videos.

5. To turn off SPLIT, press the SPLIT/VFX [A] or [B] button once again.

Using a Visual Effect (VFX)

Here's how you can apply an effect to the entire video, such as varying the video's color or shape.

You can apply a visual effect (VFX) to the A/PGM bus and B/PST bus respectively.

Selecting a Visual Effect

1. Press the [MENU] button → "SPLIT/VFX" → select "SPLIT/VFX A" or "SPLIT/VFX B", and press the [VALUE] knob.

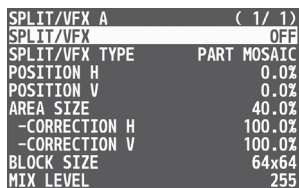

2. Use the [VALUE] knob to select "SPLIT/VFX TYPE", and press the [VALUE] knob.

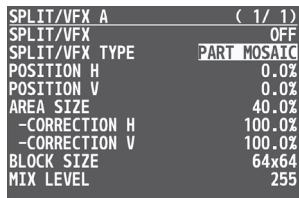

3. Use the [VALUE] knob to select the visual effect, and press the [VALUE] knob.

* With the factory settings, "PART MOSAIC" is specified.

Type	Explanation
PART MOSAIC	Applies a mosaic to the selected region.
BACKGROUND MOSAIC	Applies a mosaic to the portion outside the selected region.
FULL MOSAIC	Applies a mosaic to the entire screen.
WAVE	Makes the video wavy.
RGB REPLACE	Exchanges the colors.
COLORPASS	Turns the video black and white while preserving a specific color.
NEGATIVE	Inverts the brightness and saturation.
COLORIZE	Adds color to the video.
POSTERIZE	Changes the gradations in brightness.
SILHOUETTE	Separates the video into light and dark areas, and makes the dark areas black and adds a different color to the light areas.
EMBOSS	Adds a bas-relief effect to the video.
FIND EDGES	Extracts contours.
MONOCOLOR	Turns the video monochrome.
HUE OFFSET	Changes the visual character by controlling the hue.
SATURATION OFFSET	Changes the visual character by controlling the saturation.
VALUE OFFSET	Changes the visual character by controlling the brightness.

4. Press the [MENU] button to quit the menu.

Applying Visual Effects

1. Press a Cross-point A or B [1]–[8] button to output the video to which you want to apply the effect.

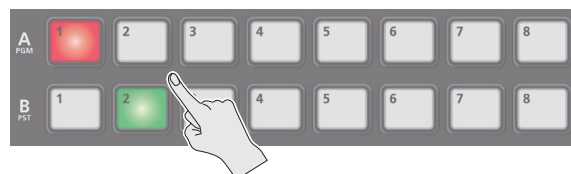

2. Press the SPLIT/VFX [A] or [B] button to turn on the visual effect (making the button light up).

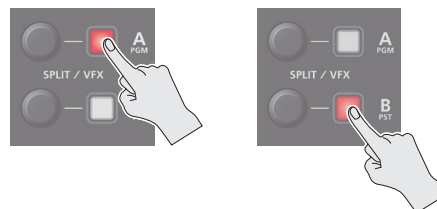

The visual effect is applied to the output video.

3. Use the SPLIT/VFX [A] or [B] knob to adjust the degree of effect applied.

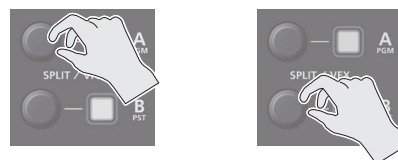

4. To turn off a visual effect, press the SPLIT/VFX [A] or [B] button once again.

MEMO

- For "PART MOSAIC" and "BACKGROUND MOSAIC", you can adjust the following settings.

Knob operation	Explanation
Turning	Adjusts the horizontal position of the selected area.
	While pressing an A or B [1]–[8] button: Adjusts the size of the selected area.
	Adjusts the vertical position of the selected area.
Turn while pressing	While pressing an A or B [1]–[8] button: Specifies the fineness (block size) of the mosaic.

- Settings for the effect that is controlled by the SPLIT/VFX [A] or [B] knobs can be checked in the VFX menu.
- By holding down the SPLIT/VFX [A] or [B] button and pressing the [MENU] button, the SPLIT/VFX A or B menu appears.
- By holding down the SPLIT/VFX [A] or [B] button and turning the SPLIT/VFX [A] or [B] knob, you can change the type of visual effect.

Compositing Video with Picture-in-Picture (PinP)

Here's how to composite an inset screen (a small separate screen) onto the background video.

You can use PinP 1 and PinP 2 simultaneously to composite two inset screens.

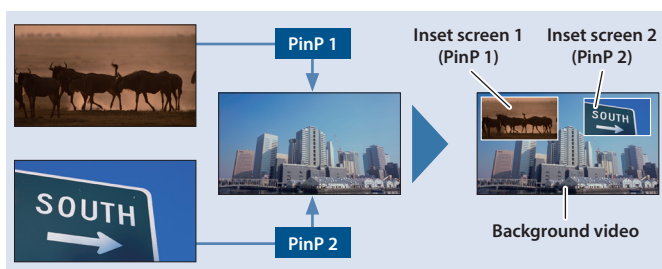

Here we explain the procedure for compositing video using "PinP 1". You can also composite video using the same procedure using "PinP 2".

1. Press a Cross-point A or B [1]–[8] button to select the video you want to make the background video.

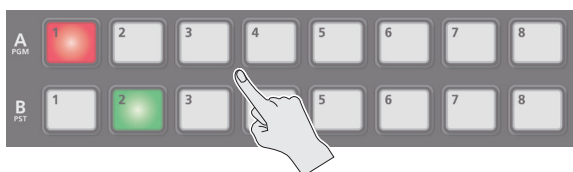

2. Press the [MODE] button to select "PinP 1 SOURCE".

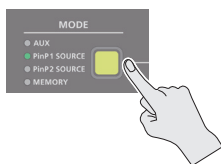

3. Press a PinP SOURCE [1]–[8] button to select the video you want to make the inset screen.

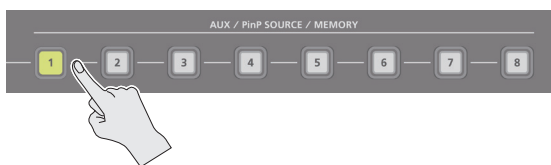

4. Press the PinP 1 [PVW] button to preview-output the video of the inset screen.

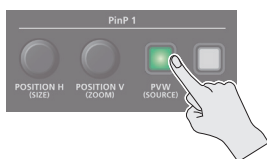

The PinP 1 [PVW] button lights up in green and the inset screen appears in the PVW section of the monitor, allowing you to check the inset screen's location and size.

At this stage, the final output has not yet been changed.

5. Use the PinP 1 [POSITION H] and [POSITION V] knobs to adjust the display position of the inset screen.

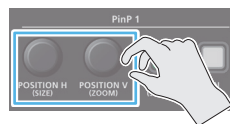

Knob	Explanation
[POSITION H]	Adjusts the inset screen's display position horizontally. Turn while pressing: Adjusts the size of the inset screen.
[POSITION V]	Adjusts the inset screen's display position vertically. Turn while pressing: Adjusts the zoom of the video shown in the inset screen.

6. Press the PinP 1 [ON] button to turn on PinP compositing (lit).

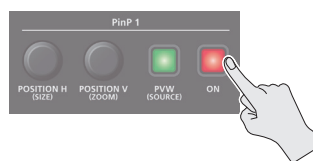

The PinP 1 [ON] button lights up in red, and the inset screen is composited onto the background video and the result is sent to final output.

7. To turn off PinP compositing, press the PinP 1 [ON] button once again.

MEMO

- By long-pressing the PinP 1 (2) [PVW] button, you can access the mode for selecting the inset screen without having to press the [MODE] button and then select "PinP 1 SOURCE" or "PinP 2 SOURCE".

While pressing the PinP 1 (2) [PVW] button, press a PinP SOURCE [1]–[8] button to select the video that you want to use as the inset screen.

- The fade time over which the inset screen appears or disappears when you press the [ON] button is specified by the setting of the TRANSITION TIME menu item "PinP 1 TIME" or "PinP 2 TIME".

- By holding down the PinP 1 (PinP 2) [PVW] button and pressing the [MENU] button, the PinP 1 or PinP 2 menu appears.

- You can make PinP/DSK composition (p. 22) turn on/off in tandem with the video transitions.

➔ "Turning PinP/DSK composition on/off in tandem with video transitions" (p. 13)

After step 5, use the [AUTO] and [CUT] buttons or operate the video fader to switch the video. PinP composition turns on, and the composited result that is previewed is sent to final output.

Making Detailed Settings for the Inset Screen

Detailed settings for size, shape, and border width etc. can be made for the PinP 1 and PinP 2 inset screens respectively.

1. Press the [MENU] button → “PinP” → select “PinP 1” or “PinP 2”, and press the [VALUE] knob.

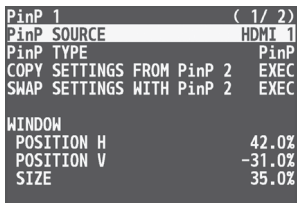

2. Use the [VALUE] knob to select a menu item, and press the [VALUE] knob.

Menu item	Explanation
WINDOW	Use the following items to adjust the inset screen.
POSITION H	Adjusts horizontal display position.
POSITION V	Adjusts vertical display position.
SIZE	Adjusts the size (zoom). This specifies the inset screen’s horizontal width as a proportion of the background video’s horizontal width.
CROPPING H	Adjusts the horizontal frame size.
CROPPING V	Adjusts the vertical frame size.
SHAPE	Specifies the shape (rectangle, circle, diamond).
BORDER COLOR	Specifies the color of the border.
BORDER WIDTH	Adjusts the width of the border.
VIEW	Use the following items to adjust the video that is shown in the inset screen.
POSITION H	Adjusts the horizontal position.
POSITION V	Adjusts the vertical position.
ZOOM	Adjusts the zoom.

3. Use the [VALUE] knob to change the value, and press the [VALUE] knob.

4. Press the [MENU] button to quit the menu.

Using Key Compositing to Remove the PinP Background Video

By changing the PinP type, you can composite the video by applying “luminance key” (p. 23) or “chroma key” (p. 25) to the PinP.

If you apply the luminance key function, the black or white portion of the inset screen becomes transparent, extracting the text or image and compositing it onto the background video.

If you apply the chroma key function, and a video that was shot against a blue or green backdrop is selected as the inset screen, the blue or green portion of the inset screen becomes transparent, extracting only the subject and compositing it onto the background video.

1. Press the [MENU] button → “PinP” → select “PinP 1” or “PinP 2”, and press the [VALUE] knob.

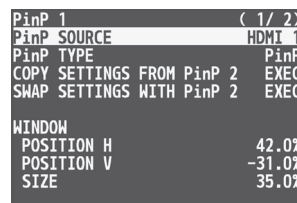

2. Use the [VALUE] knob to select “PinP TYPE”, and press the [VALUE] knob.

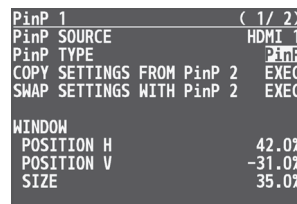

3. Use the [VALUE] knob to select the PinP type, and press the [VALUE] knob.

Type	Explanation
LUMINANCE-WHITE KEY	Composite using luminance key. Makes white portions transparent according to brightness.
LUMINANCE-BLACK KEY	Composite using luminance key. Makes black portions transparent according to brightness.
CHROMA KEY	Composite using chroma key. Makes the specified key color transparent according to hue.

4. Press the [MENU] button to quit the menu.

Copying the PinP Settings

You can copy the PinP 2 settings to PinP 1, or the settings of PinP 1 to PinP 2.

1. Press the [MENU] button → "PinP" → select "PinP 1" or "PinP 2", and press the [VALUE] knob.

```

PinP 1 ( 1 / 2 )
PinP SOURCE HDMI 1
PinP TYPE PinP
COPY SETTINGS FROM PinP 2 EXEC
SWAP SETTINGS WITH PinP 2 EXEC

WINDOW
POSITION H 42.0%
POSITION V -31.0%
SIZE 35.0%
  
```

2. Use the [VALUE] knob to select "COPY SETTINGS FROM PinP 2 (or PinP 1)", and press the [VALUE] knob.

A confirmation message appears.

```

PinP 1 ( 1 / 2 )
PinP SOURCE HDMI 1
PinP TYPE PinP
COPY SETTINGS FROM PinP 2 EXEC
SWAP SETTINGS WITH PinP 2 EXEC

WINDOW
POSITION H 42.0%
POSITION V -31.0%
SIZE 35.0%
  
```

UNSAVED SETTING
WILL BE LOST.
CANCEL OK

* If you decide to cancel, press the [EXIT] button.

3. Use the [VALUE] knob to select "OK", and press the [VALUE] knob.

The PinP settings are copied.

When the operation is finished, the message "COMPLETE" appears.

4. Press the [MENU] button to quit the menu.

Exchanging the PinP 1 and PinP 2 Settings

You can exchange the settings of PinP 1 and PinP 2.

By using this function when (for example) the PinP 1 inset screen is in the foreground and the PinP 2 inset screen is behind, you can exchange the settings so that the PinP 1 screen moves behind and the PinP 2 inset screen moves to the foreground.

1. Press the [MENU] button → "PinP" → select "PinP 1" or "PinP 2", and press the [VALUE] knob.

```

PinP 1 ( 1 / 2 )
PinP SOURCE HDMI 1
PinP TYPE PinP
COPY SETTINGS FROM PinP 2 EXEC
SWAP SETTINGS WITH PinP 2 EXEC

WINDOW
POSITION H 42.0%
POSITION V -31.0%
SIZE 35.0%
  
```

2. Use the [VALUE] knob to select "SWAP SETTINGS WITH PinP 2 (or PinP 1)", and press the [VALUE] knob.

A confirmation message appears.

```

PinP 1 ( 1 / 2 )
PinP SOURCE HDMI 1
PinP TYPE PinP
COPY SETTINGS FROM PinP 2 EXEC
SWAP SETTINGS WITH PinP 2 EXEC

WINDOW
POSITION H 42.0%
POSITION V -31.0%
SIZE 35.0%
  
```

SWAP PinP SETTINGS
ARE YOU SURE?
NO YES

* If you decide to cancel, press the [EXIT] button.

3. Use the [VALUE] knob to select "YES", and press the [VALUE] knob.

The PinP 1 and PinP 2 settings are exchanged.

When the operation is finished, the message "COMPLETE" appears.

4. Press the [MENU] button to quit the menu.

Compositing Video with Downstream Keyer (DSK)

Here's how you can turn a portion of the video transparent and composite it with the background video. You can use luminance key with either a black or a white background, or a chroma key with either a blue or green background.

You can additionally composite a variety of text and images with video that was composited using PinP or another method.

About DSK Mode

There are three DSK composition modes, "self key", "alpha key" and "external key".

The following video compositing is available according to the DSK mode.

Self key

Luminance key (p. 23)

You can cut out text or an image by turning its black or white portion transparent, and then superimpose it on the background video.



Chroma key (p. 25)

You can cut out a video by turning its blue or green portion transparent, and then superimpose it on the background video. You can select a color from the video material to set as the key color.



Alpha key (p. 27)

Use alpha channels (areas which contain transparency data) to cut out still images and place them against different background video as a composite.



External key (p. 28)

Sets the key signal (the shape to be cut out) and the fill video (the video to be composited) separately. This uses the key signal to cut out the fill video and superimpose it on the background video to create the composite.

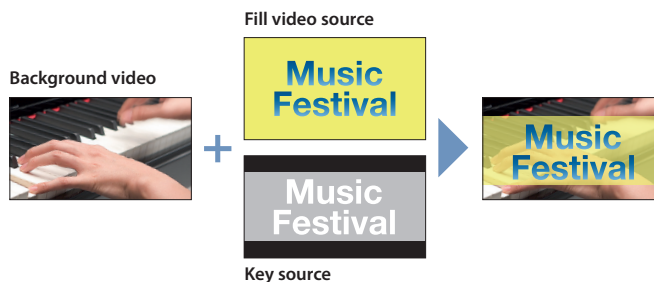

Using Luminance Key

Luminance key

This cuts out text or an image by turning the black or white portion transparent, and composites it onto the background video.



Setting the DSK mode, source and type

1. Press the [MENU] button → "DSK" → select "DSK MODE", "DSK SOURCE", or "DSK TYPE", and press the [VALUE] knob.

DSK	(1 / 3)
DSK MODE	SELF KEY
DSK SOURCE	STILL 1
DSK TYPE	LUMINANCE-WHITE
DSK LEVEL	30
DSK GAIN	62
MIX LEVEL	255

2. Use the [VALUE] knob to change the setting as shown below.

Menu item	Explanation
DSK MODE	SELF KEY
DSK SOURCE	Select the source of the text or image that you want to superimpose.
DSK TYPE	LUMINANCE-WHITE (Makes white portions transparent according to brightness.)
	LUMINANCE-BLACK (Makes black portions transparent according to brightness.)

3. Press the [MENU] button to quit the menu.

Compositing using luminance key

1. Output the background video.

At the PVW section of the monitor, check the video to be made the background.

2. Press the DSK [PVW] button to turn on the preview output (lit).

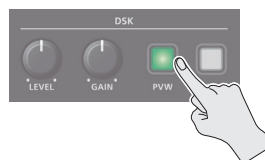

The DSK [PVW] button lights up in green, and a preview of the composition results is displayed in the PVW section of the monitor. At this stage, the final output has not yet been changed.

3. Use the DSK [LEVEL] and [GAIN] knob to adjust the degree of effect applied.



Knob	Explanation
[LEVEL]	Adjusts the degree of extraction (transparency) for the key.
[GAIN]	Adjusts the degree of edge blur (semi-transmissive region) for the key.

4. Press the DSK [ON] button to turn on luminance key composition (lit).



The DSK [ON] button lights up in red, and the composition results is sent to final output.

5. To turn off luminance key compositing, press the DSK [ON] button once again.

MEMO

- The fade time over which the text/image appears or disappears when you press the DSK [ON] button is specified by the setting of the TRANSITION TIME menu item "DSK TIME".
 - By holding down the DSK [PVW] button and pressing the [MENU] button, the DSK menu appears.
 - You can make DSK/PinP composition (p. 19) turn on/off in tandem with the video transitions.
 - ➔ "Turning PinP/DSK composition on/off in tandem with video transitions" (p. 13)
- After step 3, use the [AUTO] and [CUT] buttons or operate the video fader to switch the video. DSK composition turns on, and the composited result that is previewed is sent to final output.

Modifying the superimposed video

When using luminance key compositing, you can fill-in the superimposed image or add an edge to it.

* This setting is in common with chroma key.

1. Press the [MENU] button → select “DSK”, and press the [VALUE] knob.

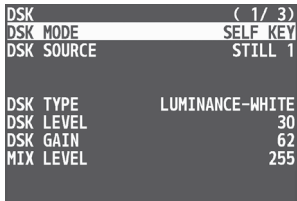

2. Use the [VALUE] knob to select the menu items shown below, and press the [VALUE] knob.



Menu item	Explanation
FILL TYPE	If this is set to “MATTE”, the superimposed text or image is filled-in with the specified color.
MATTE COLOR	
EDGE TYPE	Specifies the type of edge.
EDGE COLOR	Specifies the color of the edge.
EDGE WIDTH	Specifies the width of the edge.

3. Use the [VALUE] knob to change the value, and press the [VALUE] knob.
4. Press the [MENU] button to quit the menu.

Using Chroma Key

Chroma key

This cuts out a video by turning the blue or green portion transparent, and composites it onto the background video. Using this, you can composite only a subject that you are photographing against a blue screen or green screen.

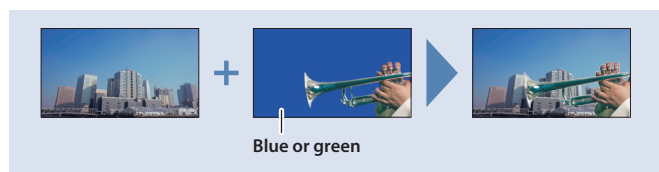

Setting the DSK mode, source and type

1. Press the [MENU] button → "DSK" → select "DSK MODE", "DSK SOURCE", "DSK TYPE", or "COLOR", and press the [VALUE] knob.

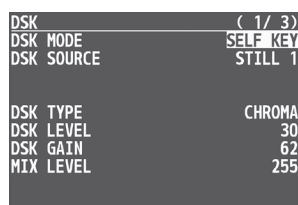

2. Use the [VALUE] knob to change the setting as shown below.

Menu item	Explanation
DSK MODE	SELF KEY
DSK SOURCE	Select the source of the video that you want to superimpose.
DSK TYPE	CHROMA
COLOR	Specify either "GREEN" or "BLUE" as the key color (the color to be removed). You can also specify a color you desire as the key color (p. 26).

3. Press the [MENU] button to quit the menu.

Compositing using chroma key

1. Output the background video.

At the PVW section of the monitor, check the video to be made the background.

2. Press the DSK [PVW] button to turn on the preview output (lit).

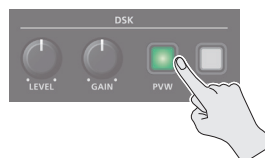

The DSK [PVW] button lights up in green, and a preview of the composition results is displayed in the PVW section of the monitor. At this stage, the final output has not yet been changed.

3. Use the DSK [LEVEL] and [GAIN] knob to adjust the degree of effect applied.



Knob	Explanation
[LEVEL]	Adjusts the degree of extraction (transparency) for the key.
[GAIN]	Adjusts the degree of edge blur (semi-transmissive region) for the key.

4. Press the DSK [ON] button to turn on chroma key composition (lit).



The DSK [ON] button lights up in red, and the composition results is sent to final output.

5. To turn off chroma key compositing, press the DSK [ON] button once again.

MEMO

- The fade time over which the video appears or disappears when you press the DSK [ON] button is specified by the setting of the TRANSITION TIME menu item "DSK TIME".
 - By holding down the DSK [PVW] button and pressing the [MENU] button, the DSK menu appears.
 - You can make DSK/PinP composition (p. 19) turn on/off in tandem with the video transitions.
 - ➔ "Turning PinP/DSK composition on/off in tandem with video transitions" (p. 13)
- After step 3, use the [AUTO] and [CUT] buttons or operate the video fader to switch the video. DSK composition turns on, and the composited result that is previewed is sent to final output.

Finely adjusting the key color (removed color)

1. Press the [MENU] button → select “DSK”, and press the [VALUE] knob.
2. Use the [VALUE] knob to select the menu items shown below, and press the [VALUE] knob.



Menu item	Explanation
CHROMA	Use the following items to make fine adjustments to the key color.
HUE WIDTH	Adjusts the hue width.
HUE FINE	Adjusts the center position of the hue.
SATURATION WIDTH	Adjusts the saturation width.
SATURATION FINE	Adjusts the center position of saturation.

3. Use the [VALUE] knob to change the value, and press the [VALUE] knob.
4. Press the [MENU] button to quit the menu.

Modifying the superimposed video

When using chroma key compositing, you can fill-in the superimposed image or add an edge to it.

* This setting is in common with luminance key.

1. Press the [MENU] button → select “DSK”, and press the [VALUE] knob.
2. Use the [VALUE] knob to select the menu items shown below, and press the [VALUE] knob.



Menu item	Explanation
FILL TYPE	If this is set to “MATTE”, the superimposed video is filled-in with the specified color.
MATTE COLOR	The fill-in color is specified by “MATTE COLOR”.
EDGE TYPE	Specifies the type of edge.
EDGE COLOR	Specifies the color of the edge.
EDGE WIDTH	Specifies the width of the edge.

3. Use the [VALUE] knob to change the value, and press the [VALUE] knob.
4. Press the [MENU] button to quit the menu.

To specify a desired color as the key color (sampling marker)

You can specify the key color to be made transparent simply by sampling (detecting) a color from the video. (This is called the sampling marker function.) You can also specify a key color other than green or blue.

1. Press the [MENU] button → “DSK” → select “SAMPLING MARKER”, and press the [VALUE] knob.

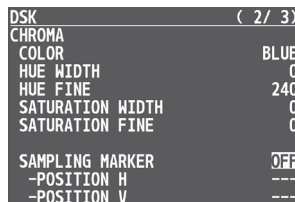

2. Use the [VALUE] knob to select “ON”, and press the [VALUE] knob.
The sampling marker (cross-shaped cursor) is shown on the monitor of the unit and in the OUTPUT 3 connector’s output video.
3. Use the [VALUE] knob to select “POSITION H” or “POSITION V”, and press the [VALUE] knob.
4. Use the [VALUE] knob to adjust the position of the sampling marker.

Menu item	Explanation
POSITION H	Adjusts the horizontal position.
POSITION V	Adjusts the vertical position.

5. Use the [VALUE] knob to select “SAMPLING EXECUTE”, and press the [VALUE] knob.

A confirmation message appears.



* If you decide to cancel, press the [EXIT] button.

6. Use the [VALUE] knob to select “YES”, and press the [VALUE] knob.
The key color is sampled.
The “HUE WIDTH”, “HUE FINE”, “SATURATION WIDTH”, and “SATURATION FINE” settings are adjusted automatically.
7. Press the [MENU] button to quit the menu.

Compositing a Still Image with Alpha Channel

Alpha key

Use alpha channels (areas which contain transparency data) to cut out still images and place them against different background video as a composite.



Setting the DSK mode or a still image to composite

1. Press the [MENU] button → "DSK" → select "DSK MODE" or "DSK SOURCE", and press the [VALUE] knob.

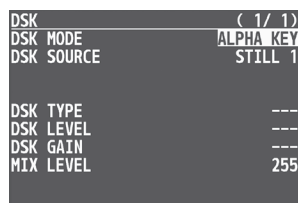

2. Use the [VALUE] knob to change the setting as shown below.

Menu item	Explanation
DSK MODE	ALPHA KEY
DSK SOURCE	Select the still image with alpha channel.

3. Press the [MENU] button to quit the menu.

Compositing using DSK

1. Output the background video.

At the PVW section of the monitor, check the video to be made the background.

2. Press the DSK [PVW] button to turn on the preview output (lit).

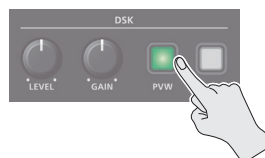

The DSK [PVW] button lights up in green, and a preview of the composition results is displayed in the PVW section of the monitor.

At this stage, the final output has not yet been changed.

3. Press the DSK [ON] button to turn on DSK compositing (lit).



The DSK [ON] button lights up in red, and the composition results is sent to final output.

4. To turn off DSK compositing, press the DSK [ON] button once again.

MEMO

- The fade time over which the still image appears or disappears when you press the DSK [ON] button is specified by the setting of the TRANSITION TIME menu item "DSK TIME".
- By holding down the DSK [PVW] button and pressing the [MENU] button, the DSK menu appears.
- You can make DSK/PinP composition (p. 19) turn on/off in tandem with the video transitions.
 - ➔ "Turning PinP/DSK composition on/off in tandem with video transitions" (p. 13)
- After step 2, use the [AUTO] and [CUT] buttons or operate the video fader to switch the video. DSK composition turns on, and the composited result that is previewed is sent to final output.
- If the DSK mode is set to "alpha key" or "external key" (p. 28), the same video that's sent to the PGM bus is also sent to the AUX bus (p. 16).
 - * This disables the AUX [1]–[8] button selection (the buttons go dark).

Using an External Key

External key

This sets the key signal (the shape to be cut out) and the fill video (the video to be composited) separately. With an external key, the key signal is used to cut out the fill video and superimpose it on the background video to create the composite.

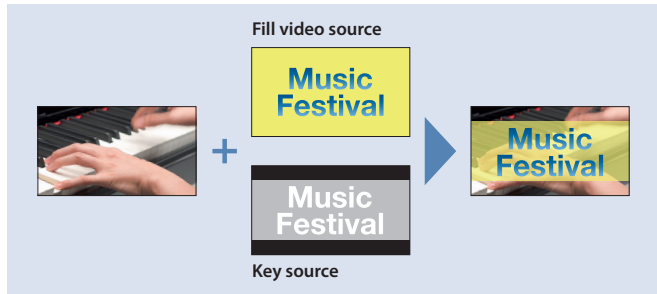

Setting the DSK mode or key/fill video

1. Press the [MENU] button → “DSK” → select “DSK MODE”, “KEY SOURCE”, or “FILL SOURCE”, and press the [VALUE] knob.

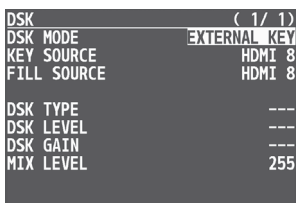

2. Use the [VALUE] knob to change the setting as shown below.

Menu item	Explanation
DSK MODE	EXTERNAL KEY
KEY SOURCE	Select the video to use as the key signal.
FILL SOURCE	Select the fill video source.

3. Press the [MENU] button to quit the menu.

Compositing using DSK

1. Output the background video.

At the PVW section of the monitor, check the video to be made the background.

2. Press the DSK [PVW] button to turn on the preview output (lit).



The DSK [PVW] button lights up in green, and a preview of the composition results is displayed in the PVW section of the monitor.

At this stage, the final output has not yet been changed.

3. Press the DSK [ON] button to turn on DSK compositing (lit).

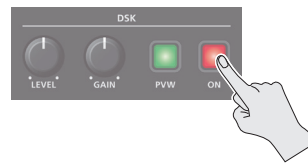

The DSK [ON] button lights up in red, and the composition results is sent to final output.

4. To turn off DSK compositing, press the DSK [ON] button once again.

MEMO

- The fade time over which the DSK video appears or disappears when you press the DSK [ON] button is specified by the setting of the TRANSITION TIME menu item “DSK TIME”.
- By holding down the DSK [PVW] button and pressing the [MENU] button, the DSK menu appears.
- You can make DSK/PinP composition (p. 19) turn on/off in tandem with the video transitions.
 - ➔ “Turning PinP/DSK composition on/off in tandem with video transitions” (p. 13)
- After step 2, use the [AUTO] and [CUT] buttons or operate the video fader to switch the video. DSK composition turns on, and the composited result that is previewed is sent to final output.
- If the DSK mode is set to “alpha key” (p. 27) or “external key”, the same video that’s sent to the PGM bus is also sent to the AUX bus (p. 16).
 - * This disables the AUX [1]–[8] button selection (the buttons go dark).

Using Imported Still Images

You can take a still image captured from input/output video or imported from a USB flash drive, assign it to channel 1 or 8, and output it in the same way as video. You can also use it as a source for DSK compositing (p. 22).

You can save up to eight still images in the unit.

* Sample materials are stored in this unit (STILL 1) by factory default.

To overwrite or delete the sample materials, revert the unit to its original state by performing a factory reset (p. 64).

* When still images are saved in the unit, startup takes longer time according to image size and the number of still images saved.

Capturing a Still Image from Input/Output Video

This captures a still image from input/output video and saves it in the unit.

NOTE

- All audio stops during still-image capture. You can make the audio keep playing while you capture images if you set the save method for still images to "temporarily save". With this setting, the imported still image is deleted when the power is turned off. Use the [MENU] button → "STILL IMAGE" → and set "SAVE TO INTERNAL STORAGE" to "DISABLE".
- Depending on the format of the input video, completion of still-image capture might take some time.

1. Press the [CAPTURE IMAGE] button to turn on (lit).



The monitor shows a list of still images (STILL 1-8).

The Cross-point A [1]-[8] buttons blink yellow.

2. Press a Cross-point A [1]-[8] button to select a save-destination (STILL 1-8) for the captured still image.

* If you decide to cancel, press the [EXIT] button.



- When you select the save-destination for the still image, the list of still images changes to a list of video inputs (HDMI 1-8).
- The Cross-point A buttons of channels that are inputting video and the [CUT] button blink red.

3. Press a button that is blinking red to capture a still image.

* If you decide to cancel, press the [EXIT] button.

If you press a Cross-point A [1]-[8] button

The still image is captured from the video that is being input to the channel whose button you pressed.

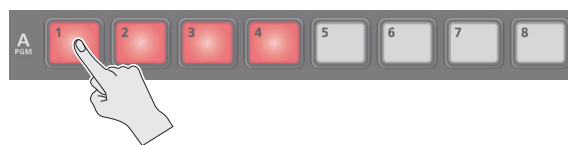

If you press the [CUT] button

The still image is captured from the PGM (final output) video.



- When you execute capture, the list of input video changes to a list of still images.

* Do not turn off the power while the "PLEASE WAIT" message is shown.

4. When the display indicates "COMPLETE", press the [EXIT] button to exit the operation.

MEMO

When you have captured from copyright-protected (HDCP) video, the created still image is treated the same way as HDCP applied video.

The still image is switched between displayed and hidden by turning HDCP on and off (p. 10).

Note, however, that when HDCP is switched from off to on, the still image is reloaded from where it's saved in memory, and so the still image might take some time to display.

Importing a Still Image from a USB Flash Drive

This imports into the unit a still image saved on a USB flash drive.

Supported still-image formats and resolutions

Format	Bitmap file (.bmp), 24-bit color, uncompressed
	PNG file (.png), 24-bit color
	* Alpha channel supported
Resolution	JPEG file (.jpg, .jpeg), 24-bit color
Resolution	In conformity with system format (p. 8)
File name	No more than 28 single-byte alphanumeric characters
	* Be sure to append the file extension.

Importing a still image

NOTE

- Large-size still-image files might take some time to import.
- When you're using a USB flash drive for the first time, be sure to format it on the V-8HD (p. 60).
- Depending on the USB flash drive, recognition of the flash drive might take some time.

1. Save the still image in the root directory of the USB flash drive.
2. Connect the USB flash drive containing the saved still image to the USB MEMORY port.
3. Press the [MENU] button → "STILL IMAGE" → select "LOAD FROM USB MEMORY", and press the [VALUE] knob.

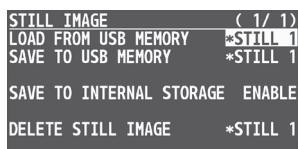

A "*" symbol is displayed for memory where a still image is already saved.

4. Use the [VALUE] knob to select the still image save-destination (STILL 1–8), and then press the [VALUE] knob.

The names of the files on the USB flash drive are displayed on this screen.

5. Select the still image file you want to import, and press the [VALUE] knob.

A confirmation message appears.



* If you decide to cancel, press the [EXIT] button.

6. Use the [VALUE] knob to select "YES", and press the [VALUE] knob.

The still image is imported into the unit.

7. Press the [MENU] button to quit the menu.

Assigning Still Images to Channel 1–8

Here's how a still image saved in this unit (STILL 1–8) can be assigned to channels 1–8.

1. Press the [MENU] button → "VIDEO INPUT" → select "INPUT 1"–"INPUT 8 (SCALER)", and press the [VALUE] knob.

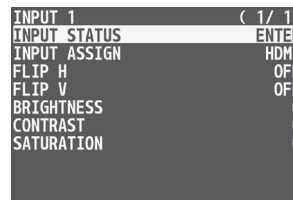

2. Use the [VALUE] knob to select "INPUT ASSIGN", and press the [VALUE] knob.

3. Use the [VALUE] knob to select "STILL 1"–"STILL 8", and press the [VALUE] knob.

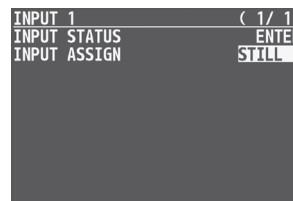

4. Press the [MENU] button to quit the menu.

MEMO

- By holding down the [EXIT] button and pressing a Cross-point A or B [1]–[8] button, you can switch between still images STILL 1–8 and select the still image that is assigned to the channel whose button you pressed.
- You can use the USER [1] or [2] button to output the specified still image.
This lets you directly output a still image to PGM and PVW without assigning it to a channel.
For details on this setting, refer to "Assigning the Functions of the USER [1] [2] Buttons" (p. 63).
- You can use the [OUTPUT FADE] knob to output a specified still image.
This lets you directly output a still image to PGM and PVW without assigning it to a channel.
For details on this setting, refer to "Specifying the function of the [OUTPUT FADE] knob" (p. 33).
- You can use a footswitch or expression pedal to output a specified still image. This lets you directly output a still image to PGM and PVW without assigning it to a channel.
For details on this setting, refer to the following.
 - "Using a Footswitch" (p. 61)
 - "Using an Expression Pedal" (p. 62)

Deleting a Still Image

Here's how to delete the still image that's saved in the unit.

1. Press the [MENU] button → "STILL IMAGE" → select "DELETE STILL IMAGE", and press the [VALUE] knob.



2. Use the [VALUE] knob to select the still image you want to delete, and press the [VALUE] knob.

A confirmation message appears.



* If you decide to cancel, press the [EXIT] button.

3. Use the [VALUE] knob to select "YES", and press the [VALUE] knob.

The still image is deleted. When the operation is finished, the message "COMPLETE" appears.

* Do not turn off the power while the "PLEASE WAIT" message is shown.

4. Press the [MENU] button to quit the menu.

Saving a Still Image to a USB Flash Drive

Here's how a still image captured from the input/output video (p. 29) can be saved to a USB flash drive.

* An image captured while HDCP is ON cannot be saved.

Saving a new still image file

1. Connect the USB flash drive to the USB MEMORY port.
2. Select the [MENU] button → "STILL IMAGE" → "SAVE TO USB MEMORY", and press the [VALUE] knob.



A "*" symbol is displayed for memory where a still image is already saved.

3. Use the [VALUE] knob to select the memory (STILL 1– 8) for the still image that you want to save, and press the [VALUE] knob.

The SAVE STILL IMAGE screen appears.

4. Use the [VALUE] knob to select "NEW FILE...!", then press the [VALUE] knob.

5. Use the [VALUE] knob to select the FILE TYPE, then press the [VALUE] knob.



- 1 Use the [VALUE] knob to Select the file format (BITMAP, PNG, JPEG).

- 2 Press the [VALUE] knob.

6. Enter a file name.

* You can enter a text string of up to 16 characters in length.



- 1 Use the [VALUE] knob to move the cursor.

Pressing the [EXIT] button deletes the character at the cursor location.

- 2 Press the [VALUE] knob to highlight the character at the cursor location.

- 3 Use the [VALUE] knob to change the character, and press the [VALUE] knob.

- When you finish entering the name, use the [VALUE] knob to select "SAVE"; then press the [VALUE] knob.

A confirmation message appears.



* If you decide to cancel, press the [EXIT] button.

- Use the [VALUE] knob to select "YES"; then press the [VALUE] knob.

The still image is written to the USB flash drive.

- Press the [MENU] button to quit the menu.

Overwrite-saving a still image file

- Connect the USB flash drive to the USB MEMORY port.
- Select the [MENU] button → "STILL IMAGE" → "SAVE TO USB MEMORY", and press the [VALUE] knob.

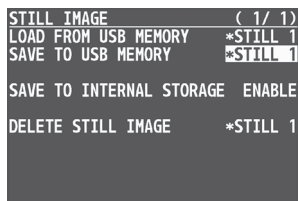

A "*" symbol is displayed for memory where a still image is already saved.

- Use the [VALUE] knob to select the memory (STILL 1–8) for the still image that you want to save, and press the [VALUE] knob.

The SAVE STILL IMAGE screen appears.

- Use the [VALUE] knob select the file to overwrite, and press the [VALUE] knob.

A confirmation message appears.

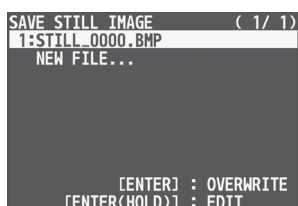

* If you decide to cancel, press the [EXIT] button.
 * If you long-press the [VALUE] knob, the edit screen opens with the file name and file format preserved.

- Press the [VALUE] knob.

The file (.V08) is newly saved on the USB flash drive.

- Press the [MENU] button to quit the menu.

Freezing Input Video (Freeze)

This temporarily pauses the incoming video.

You can apply transition effects and visual effects during a video freeze.

Setting the freeze mode

There are two freeze modes: "ALL" and "SELECT".

* With the factory settings, "ALL" is selected.

Mode	Explanation
ALL	Freezes all video that is being input.
SELECT	Freezes only the specified input video.

- Press the [MENU] button → "FREEZE" → select "TYPE", and press the [VALUE] knob.



- Use the [VALUE] knob to select "ALL" or "SELECT", and press the [VALUE] knob.

If "SELECT" is selected

- Use the [VALUE] knob to select "HDMI IN 1"–"HDMI IN 8", and press the [VALUE] knob.

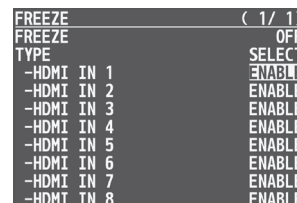

- Use the [VALUE] knob to select "ENABLE" or "DISABLE", and press the [VALUE] knob.

Value	Explanation
ENABLE	The input video freezes.
DISABLE	The input video does not freeze.

- Press the [MENU] button to quit the menu.

Applying a Fade to the Output Video (Output Fade)

You can apply a fade to the output video.

This lets you make the main output video fade to a black (or white) picture at times when you want to suppress video output, such as during intervals in a presentation, event or band performance.

Applying a Fade-out

1. Turn the [OUTPUT FADE] knob all the way clockwise or counterclockwise.

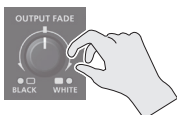

Turning the [OUTPUT FADE] knob clockwise performs a fade-out to white, and turning the knob counterclockwise performs a fade-out to black (factory setting).

Applying a fade makes the indicators to the left or right of the knob flash.

Applying a Fade-in

1. Return the [OUTPUT FADE] knob to its center position.

The indicator stops flashing and lights up steadily, and output starts.

Specifying the function of the [OUTPUT FADE] knob

You can assign the following functions to the [OUTPUT FADE] knob.

- Fade the output video.
- Adjusts the volume of the output audio.
- Output a specified still image.

1. Press the [MENU] button → “SYSTEM” → select OUTPUT FADE ASSIGN “TURN LEFT” or “TURN RIGHT”, and then press the [VALUE] knob.

```

SYSTEM ( 2 / 4 )
OUTPUT FADE ASSIGN
-TURN LEFT BLACK&AUDIO
-TURN RIGHT WHITE&AUDIO
USER 1 SW
-CATEGORY FREEZE
-VALUE ---
USER 2 SW
-CATEGORY AUTO SWITCHING
-VALUE AUTO SWITCHING SW
LED DIMMER 8
LCD DIMMER 8
    
```

2. Use the [VALUE] knob to select the function of the [OUTPUT FADE] knob, and then press the [VALUE] knob.

Value	Explanation
BLACK	Fade out to black.
WHITE	Fade out to white.
AUDIO	Adjust the volume of the output audio.
BLACK&AUDIO	Simultaneously apply the fade-to-black and the output audio volume adjustment functions.
WHITE&AUDIO	Simultaneously apply the fade-to-white and the output audio volume adjustment functions.
STILL 1-8 OUTPUT	Output the specified still image.

3. Press the [MENU] button to quit the menu.

Audio Operations

Adjusting the Volume Level

Here's how to adjust the volume of the audio input and audio output.

1. Press the [MENU] button → "AUDIO INPUT" → select "HDMI IN 1"–"HDMI IN 8" or "AUDIO IN", and press the [VALUE] knob.



2. Use the [VALUE] knob to select "INPUT LEVEL", and press the [VALUE] knob.
3. Use the [VALUE] knob to adjust the input volume, and press the [VALUE] knob.
4. Press the [MENU] button.

5. Press the [MENU] button → "AUDIO OUTPUT" → "MASTER OUTPUT" → select "OUTPUT LEVEL", and press the [VALUE] knob.



6. Use the [VALUE] knob to adjust the output volume, and press the [VALUE] knob.
7. Press the [MENU] button to quit the menu.

Level meter indication

The audio level meter is shown in each section of the multi-view monitor.

The level meter illumination lets you check whether the volume is adjusted appropriately.

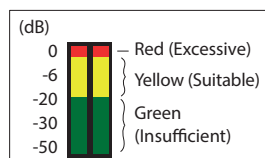

Indicator	Status
Red	Lights up at 0 dB or higher. It indicates an excessive volume level.
Yellow	Lights up at -20 to -1 dB. It indicates an appropriate volume level.
Green	Lights up at -50 to -21 dB. It indicates a too-low volume level.

* If the volume level of speaker output is unsuitable even when the volume level on the V-8HD has been adjusted so that level meter light up in yellow, adjust the volume for the speakers and amplifiers. Using "OUTPUT LEVEL" to make adjustments can sometimes result in distortion or poorer sound quality.

MEMO

- If the OUTPUT FADE ASSIGN (p. 33) setting is "BLACK&AUDIO" or "WHITE&AUDIO", using the [OUTPUT FADE] knob to fade-in/out the output video will simultaneously fade-in/out the output audio as well.
- If the OUTPUT FADE ASSIGN (p. 33) setting is "AUDIO", you can use the [OUTPUT FADE] knob to adjust only the output volume.
- You can output a test tone that is useful when making volume adjustments.
In the SYSTEM menu item "TEST TONE" (p. 87), specify the test tone that you want to output.

Adjusting the output volume of the AUX bus

1. Press the [MENU] button → "AUDIO OUTPUT" → "AUX" → select "AUX LEVEL", and press the [VALUE] knob.

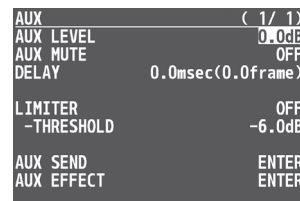

2. Use the [VALUE] knob to adjust the output volume, and press the [VALUE] knob.
3. Press the [MENU] button to quit the menu.

Applying Effects to Input Audio

You can modify the tonal character by applying effects to the audio input.

Using an effect preset

The V-8HD is equipped with effects that are adjusted for specific environments. These are called “effect presets”.

The effect presets are created using a combination of three effects (high-pass filter, compressor, equalizer).

Simply by selecting an effect preset, you can easily apply an effect that’s appropriate for your situation.

MEMO

- When you switch presets, the settings of each effect are overwritten.
- If you want to make fine adjustments to a preset, use the AUDIO INPUT menu to edit the high-pass filter, compressor, and equalizer settings.

Since the noise gate (an effect that eliminates noise) is not included in the presets, you’ll need to make separate settings for it.

For details on the effects, refer to p. 75.

1. Press the [MENU] button → “AUDIO INPUT” → select “HDMI IN 1” – “HDMI IN 8” or “AUDIO IN”, and press the [VALUE] knob.

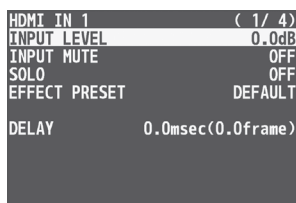

2. Use the [VALUE] knob to select “EFFECT PRESET”, and press the [VALUE] knob.

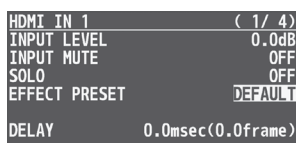

3. Use the [VALUE] knob to select the effect preset, and press the [VALUE] knob.

Value	Explanation
DEFAULT	For line input (default setting)
MEETING	For meetings
INTERVIEW	For interviews
AMBIENT MIC	For capturing ambient sound
WINDY FIELD	For capturing ambient sound in a windy area
DE-ESS & POPS SOFT	For reducing sibilants
DE-ESS & POPS HARD	For reducing plosives

A confirmation message appears.



* If you decide to cancel, press the [EXIT] button.

4. Use the [VALUE] knob to select “OK”, and press the [VALUE] knob.

The preset is loaded. When the operation is finished, the message “COMPLETE” appears.

5. Press the [MENU] button to quit the menu.

Correcting a time difference between video and audio (delay)

Here’s how you can correct a time difference between the video and audio by delaying the output of the input audio.

1. Press the [MENU] button → “AUDIO INPUT” → select “HDMI IN 1” – “HDMI IN 8” or “AUDIO IN”, and press the [VALUE] knob.

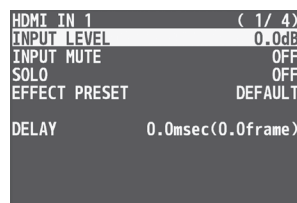

2. Use the [VALUE] knob to select “DELAY”, and press the [VALUE] knob.

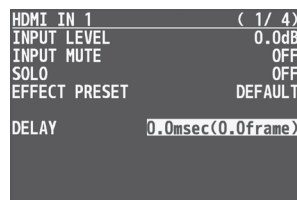

3. Use the [VALUE] knob to adjust the time by which the audio is delayed, and press the [VALUE] knob.

Delay the audio output so that the audio and video match.

4. Press the [MENU] button to quit the menu.

Applying Effects to Output Audio

You can modify the tonal character by applying effects to the audio output.

* You can apply a limiter (LIMITER) to the audio of the AUX bus.

1. Press the [MENU] button → "AUDIO OUTPUT" → select "MASTER OUTPUT" or "AUX", and press the [VALUE] knob.

```

MASTER OUTPUT ( 1 / 3 )
OUTPUT LEVEL 0.0dB
OUTPUT MUTE OFF

LIMITER OFF
-THRESHOLD -6.0dB
    
```

(for AUX)

```

AUX ( 1 / 1 )
AUX LEVEL 0.0dB
AUX MUTE OFF
DELAY 0.0msec(0.0frame)

LIMITER OFF
-THRESHOLD -6.0dB

AUX SEND ENTER
AUX EFFECT ENTER
    
```

2. Use the [VALUE] knob to select an effect menu item, and then press the [VALUE] knob.

```

MASTER OUTPUT ( 2 / 3 )
EQUALIZER OFF
-Hi GAIN 0.0dB
-Hi FREQUENCY 10.0kHz
-Mid GAIN 0.0dB
-Mid FREQUENCY 500Hz
-Mid Q 1.0
-Lo GAIN 0.0dB
-Lo FREQUENCY 100Hz
    
```

(for AUX)

```

AUX ( 1 / 1 )
AUX LEVEL 0.0dB
AUX MUTE OFF
DELAY 0.0msec(0.0frame)

LIMITER OFF
-THRESHOLD -6.0dB

AUX SEND ENTER
AUX EFFECT ENTER
    
```

3. Use the [VALUE] knob to change the value, and press the [VALUE] knob.

4. Press the [MENU] button to quit the menu.

Delay (DELAY)

* AUX only

This outputs audio with a delay.

Delaying audio output lets you align the output timing of video and audio.

Menu item	Explanation
DELAY	This adjusts the delay time for output audio.

LIMITER

This limits the output volume so that it does not exceed the set level.

Menu item	Explanation
LIMITER	Turn the limiter on or off.
THRESHOLD	Adjusts the level that becomes the threshold at which the limiter is applied. Compression is applied to audio that exceeds the threshold. The volume level of audio that is output is limited so as to stay to below the threshold.

EQUALIZER

This limits the output volume so that it does not exceed the set level.

Menu item	Explanation
EQUALIZER	Turns the equalizer on/off.
Hi GAIN	Boosts or attenuates the high band.
Hi FREQUENCY	Specifies the center frequency when changing the tone quality in the high band.
Mid GAIN	Boosts or attenuates the middle band.
Mid FREQUENCY	Specifies the center frequency when changing the tone quality in the middle band.
Mid Q	Adjusts the width of the frequency band when boosting or attenuating the middle band.
Lo GAIN	Boosts or attenuates the low band.
Lo FREQUENCY	Specifies the center frequency when changing the tone quality in the low band.

MULTI BAND COMPRESSOR

This applies separate compressors in individual frequency bands.

Menu item	Explanation
MULTI BAND COMPRESSOR	Turns the multi-band compressor on/off.
Hi THRESHOLD Mid THRESHOLD Lo THRESHOLD	Specify the individual levels that become the thresholds for the high, midrange, and low bands at which the compressor is applied. Compression is applied to audio that exceeds the threshold.
Hi RATIO Mid RATIO Lo RATIO	Specify the amount of compression applied in the high, midrange, and low bands. The state in which no compression is applied is defined as "1".

Interlinking Audio Output to Video Switching (Audio Follow)

You can associate audio with a video switch so that when the video is switched, the specified audio alone is output automatically, and other audio is automatically muted.

1. Follow the procedure in “Adjusting the Volume Level” (p. 34) to adjust to the volume level you want to output.
2. Press the [MENU] button → select “AUDIO FOLLOW”, and press the [VALUE] knob.

AUDIO FOLLOW	(1 / 1)
ALL AUDIO FOLLOW	OFF
INPUT 1	OFF
INPUT 2	OFF
INPUT 3	OFF
INPUT 4	OFF
INPUT 5	OFF
INPUT 6	OFF
INPUT 7	OFF
INPUT 8	OFF
AUDIO IN	OFF

3. Use the [VALUE] knob to select the video channel you want to use with Audio Follow, and press the [VALUE] knob.
If you select “ALL AUDIO FOLLOW”, all input channels are used.
4. Use the [VALUE] knob to select “ON”, and press the [VALUE] knob.

Value	Explanation
ON	Enables the Audio Follow feature. Muting is performed automatically when video on another channel is output.
OFF	Disables the Audio Follow feature.

5. Press the [MENU] button to quit the menu.
6. Switch the video.
On video channels where Audio Follow is on, audio is automatically muted when video on other channels is output.

Applying audio follow to the audio from AUDIO IN

1. Press the [MENU] button → “AUDIO FOLLOW” → select “AUDIO IN”, and press the [VALUE] knob.

AUDIO FOLLOW	(1 / 1)
ALL AUDIO FOLLOW	OFF
INPUT 1	OFF
INPUT 2	OFF
INPUT 3	OFF
INPUT 4	OFF
INPUT 5	OFF
INPUT 6	OFF
INPUT 7	OFF
INPUT 8	OFF
AUDIO IN	OFF

2. Use the [VALUE] knob to select the video channel you want to use with Audio Follow, and press the [VALUE] knob.

Value	Explanation
INPUT 1-8	Specify the input channels that use audio follow for the input audio. The AUDIO IN audio is muted for input channels other than those specified.
OFF	Disables the Audio Follow feature.

3. Press the [MENU] button to quit the menu.

Outputting AUX-bus Audio

The V-8HD has two types audio buses: MASTER OUTPUT and AUX. You can assign a desired bus to each output connector.

Audio bus	Explanation
MASTER OUTPUT	All input audio is mixed and output (master output).
AUX	This mixes and outputs only the input audio that is sent to the AUX bus. This allows you to output audio that is different than the master output. For example, in a live event, you might output a mix of all audio inputs, while separately outputting a mix of only specific audio inputs (the AUX bus) for recording or streaming.

Assigning the AUX Bus

1. Press the [MENU] button → "AUDIO OUTPUT" → "OUTPUT ASSIGN" → select the output jack, and press the [VALUE] knob.

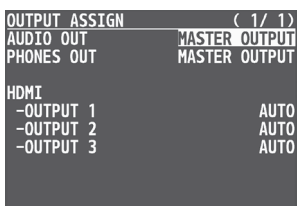

2. Use the [VALUE] knob to select "AUX" or "AUTO", and press the [VALUE] knob.

Value	Explanation						
AUTO (*1)	The audio bus automatically switches according to the video bus assignment (p. 10). <table border="1" style="margin-left: 20px;"> <thead> <tr> <th>Video bus</th> <th>Audio bus</th> </tr> </thead> <tbody> <tr> <td>Others besides AUX</td> <td>MASTER OUTPUT</td> </tr> <tr> <td>AUX</td> <td>AUX</td> </tr> </tbody> </table>	Video bus	Audio bus	Others besides AUX	MASTER OUTPUT	AUX	AUX
Video bus	Audio bus						
Others besides AUX	MASTER OUTPUT						
AUX	AUX						
MASTER OUTPUT	Output the audio of the MASTER OUTPUT bus.						
AUX	Output the audio of the AUX bus.						

(*1) For "HDMI OUTPUT 1"-"HDMI OUTPUT 3" only.

3. Press the [MENU] button to quit the menu.

Sending Audio to the AUX Bus

1. Press the [MENU] button → "AUDIO OUTPUT" → "AUX" → select "AUX SEND", and press the [VALUE] knob.

The AUX SEND menu appears.

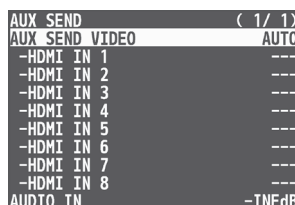

2. Use the [VALUE] knob to select the input audio, and press the [VALUE] knob.

* You can select HDMI IN 1-8 by setting "AUX SEND VIDEO" to "MANUAL".

When this is set to "AUTO", the audio is automatically sent to the AUX bus in tandem with the AUX bus video selection.

3. Use the [VALUE] knob to adjust the amount that is sent to the AUX bus, and press the [VALUE] knob.

4. Press the [MENU] button to quit the menu.

Setting the character of the sound

You can select whether to send either the original audio or the audio processed with effects to the AUX bus.

1. Press the [MENU] button → "AUDIO OUTPUT" → "AUX" → select "AUX EFFECT" and press the [VALUE] knob.

The AUX EFFECT menu appears.

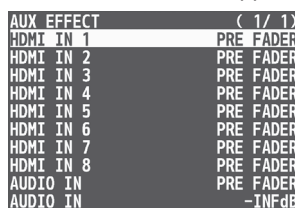

2. Use the [VALUE] knob to select the input audio, and press the [VALUE] knob.

3. Use the [VALUE] knob to select "DRY", "PRE FADE", or "POST FADER", and press the [VALUE] knob.

Value	Explanation
DRY	Sends the source audio with no effects applied.
PRE FADER	Sends the effect-applied audio. The send volume is constant, regardless of the volume (INPUT LEVEL).
POST FADER	Sends the effect-applied audio. The send volume can be changed by adjusting the volume (INPUT LEVEL).

4. Press the [MENU] button to quit the menu.

Silencing Only Specific Audio (Mute)

Here's how to temporarily silence specific input audio or output audio (the mute function).

Muting input audio

1. Press the [MENU] button → "AUDIO INPUT" → select "HDMI IN 1"–"HDMI IN 8" or "AUDIO IN", and press the [VALUE] knob.

HDMI IN 1	(1 / 4)
INPUT LEVEL	0.0dB
INPUT MUTE	OFF
SOLO	OFF
EFFECT PRESET	DEFAULT
DELAY	0.0msec(0.0frame)

2. Use the [VALUE] knob to select "INPUT MUTE", and press the [VALUE] knob.

HDMI IN 1	(1 / 4)
INPUT LEVEL	0.0dB
INPUT MUTE	OFF
SOLO	OFF
EFFECT PRESET	DEFAULT
DELAY	0.0msec(0.0frame)

3. Use the [VALUE] knob to select "ON", and press the [VALUE] knob.

4. Press the [MENU] button to quit the menu.

Muting output audio

1. Press the [MENU] button → "AUDIO OUTPUT" → "MASTER OUTPUT" → select "OUTPUT MUTE", and press the [VALUE] knob.

MASTER OUTPUT	(1 / 3)
OUTPUT LEVEL	0.0dB
OUTPUT MUTE	OFF
LIMITER	OFF
-THRESHOLD	-6.0dB

2. Use the [VALUE] knob to select "ON", and press the [VALUE] knob.

3. Press the [MENU] button to quit the menu.

Muting AUX-bus Audio

1. Press the [MENU] button → "AUDIO OUTPUT" → "AUX" → select "AUX MUTE", and press the [VALUE] knob.

AUX	(1 / 1)
AUX LEVEL	0.0dB
AUX MUTE	OFF
DELAY	0.0msec(0.0frame)
LIMITER	OFF
-THRESHOLD	-6.0dB
AUX SEND	ENTER
AUX EFFECT	ENTER

2. Use the [VALUE] knob to select "ON", and press the [VALUE] knob.

3. Press the [MENU] button to quit the menu.

Checking a Specific Audio Input (Solo)

Here's how you can temporarily monitor a specific audio input via the headphones (solo function).

* The solo function applies to the headphone output. It does not affect output other than the headphones.

1. Press the [MENU] button → "AUDIO INPUT" → select "HDMI IN 1" – "HDMI IN 8" or "AUDIO IN", and press the [VALUE] knob.

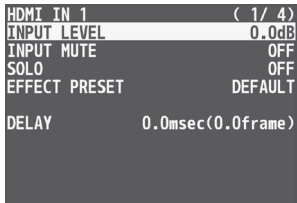

2. Use the [VALUE] knob to select "SOLO", and press the [VALUE] knob.

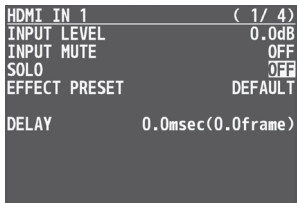

3. Use the [VALUE] knob to select "ON", and press the [VALUE] knob.
4. Press the [MENU] button to quit the menu.

Other Features

Saving/Recalling Settings (Preset Memory)

You can save the current settings, including the video/audio settings and the state of the operating panel, in preset memory and recall those settings for use when necessary. The V-8HD is provided with 24 preset memories.

* The settings are saved in preset memory as demo data by factory default.

About the last memory function

The V-8HD has a built-in Last Memory function. Last Memory is a function that saves the state of the unit that is in effect immediately before power-down, and automatically restores the state at the next startup. The Last Memory function is enabled by default. If you want the unit to recall a specific preset memory when it starts up, use the PRESET MEMORY menu item "START UP" to specify the preset memory number.

Saving to a Preset Memory

Preset memory 1–8

1. Use the [MODE] button to select "MEMORY".

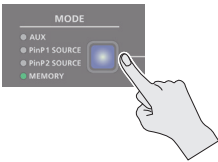

2. Long-press the MEMORY button for the number where you want to save the settings.

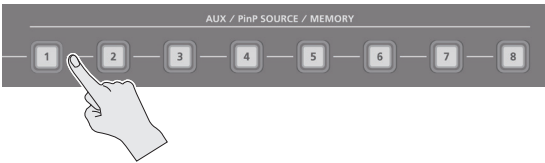

All of the MEMORY [1]–[8] buttons are briefly illuminated in light blue, and the current settings are saved in the selected preset memory.



Preset memory 9–24

1. Press the [MENU] button and select the memory number from "PRESET MEMORY" → "SAVE", and press the [VALUE] knob.

MEMO

- If you change [MENU] button → "PRESET MEMORY" → "NUMBER OF MEMORY SW" from 8 to 24, the A [1]–[8] buttons and B [1]–[8] buttons operate respectively as MEMORY 9–16 buttons and MEMORY 17–24 buttons when MODE is MEMORY.
- You can prohibit settings from being saved or initialized (p. 42) to protect the preset memories.
Use the [MENU] button → "PRESET MEMORY" → and set "MEMORY PROTECT" to "ON".
- Since settings related to the system, freeze and so on are common to the entire unit, they are not saved in a memory.
For details, refer to "SAVE" in "11: PRESET MEMORY" (p. 78).

Recalling a Preset Memory

Preset memory 1–8

1. Use the [MODE] button to select "MEMORY".

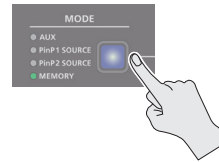

MEMORY [1]–[8] button illumination color	
Light blue	Currently selected memory
Blue	Memories in which data is saved
Unlit	Memories with no data (empty)

2. Press the MEMORY button for the number whose setting you want to recall.

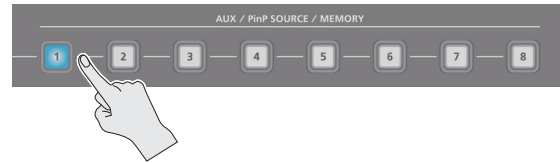

The settings are recalled.

Preset memory 9–24

1. Press the [MENU] button and select the memory number from "PRESET MEMORY" → "LOAD", and press the [VALUE] knob.

MEMO

When recalling a preset memory, you can specify the individual menu items that will be included in the recalled preset memory. To make this setting, use the [MENU] button → "PRESET MEMORY" → "LOAD PARAMETER".

Initializing a Preset Memory

You can initialize the settings of a specific preset memory and completely erase its settings.

1. Press the [MENU] button → “PRESET MEMORY” → select “INITIALIZE”, and press the [VALUE] knob.



2. Use the [VALUE] knob to select the preset memory (MEMORY 1–24) that you want to initialize, and press the [VALUE] knob.

A confirmation message appears.



* If you decide to cancel, press the [EXIT] button.

3. Use the [VALUE] knob to select “YES”, and press the [VALUE] knob.

The preset memory is initialized. When the operation is finished, the message “COMPLETE” appears.

4. Press the [MENU] button to quit the menu.

MEMO

About the preset memory demo data

Once you perform a factory reset (p. 64), any demo data you have edited or deleted is restored to its factory default settings.

Renaming a Preset Memory

Here’s how to rename a preset memory. You can assign a name of up to 8 characters to each memory.

1. Press the [MENU] button → “PRESET MEMORY” → select “NAME EDIT”, and press the [VALUE] knob.



2. Use the [VALUE] knob to select the preset memory (MEMORY 1–24) that you want to rename, and then press the [VALUE] knob.

The PRESET MEMORY NAME screen appears.

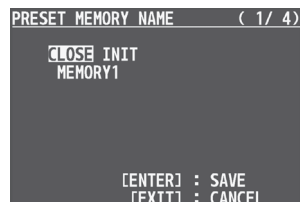

3. Use the [VALUE] knob to select the item that you want to execute, and then press the [VALUE] knob.

Item	Explanation
CLOSE	Saves the memory name and closes the PRESET MEMORY NAME screen.
INIT	Initializes the memory name.
(Memory name)	Edits the memory name (to step 4).

4. Input the memory name.

* You can input up to 8 characters.

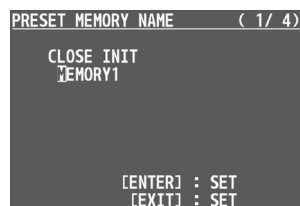

- 1 Use the [VALUE] knob to move the cursor.

If you press the [EXIT] button, the character at the cursor location is deleted.

- 2 Press the [VALUE] knob to highlight the character at the cursor location.

- 3 Use the [VALUE] knob to change the character, and then press the [VALUE] knob.

5. When you have finished inputting the name, use the [VALUE] knob to select “CLOSE”, and then press the [VALUE] knob.

* If you decide to cancel, press the [EXIT] button.

6. Press the [MENU] button to quit the menu.

Specifying the Preset Memory Switching Effect

Here's how to apply MIX/WIPE or PinP/DSK fade when switching preset memories.

1. Press the [MENU] button → “PRESET MEMORY” → select “FADE TIME”.

```
PRESET MEMORY ( 2 / 4 )
FADE TIME 0.0sec
-MIX/WIPE ON
-PinP 1 ON
-PinP 2 ON
-DSK ON
```

2. Use the [VALUE] knob to select the item that you want to set, and then press the [VALUE] knob.

Menu item	Explanation
FADE TIME	Specifies the time of the transition when loading a preset memory.
MIX/WIPE	Turns the switching effect on/off.
PinP 1	
PinP 2	
DSK	

3. Use the [VALUE] knob to change the setting, and then press the [VALUE] knob.
4. Press the [MENU] button to quit the menu.

Saving Preset Memories to a USB Flash Drive

You can group together the preset memories (1–24) into a single file (.V08preset) and save this to a USB flash drive connected to the USB MEMORY port. You can access saved preset files on the USB flash drive and load them into the unit to use as needed.

NOTE

- When using a USB flash drive for the first time, you must format it using the V-8HD (p. 60).
- Depending on the USB flash drive, recognition of the flash drive might take some time.

Saving

Saving a new file

1. Connect the USB flash drive to the USB MEMORY port.
2. Press the [MENU] button → “PRESET MEMORY” → select “SAVE TO USB MEMORY”, and press the [VALUE] knob.



The preset files on the USB flash drive are shown as a list.

3. Use the [VALUE] knob to select “NEW FILE...”, and press the [VALUE] knob.



4. Enter the file name.

* You can enter a text string of up to 16 characters in length.

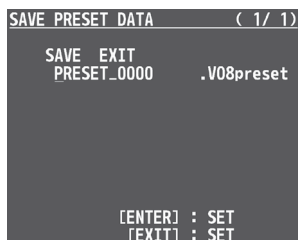

- 1 Use the [VALUE] knob to move the cursor.
Pressing the [EXIT] button deletes the character at the cursor location.
- 2 Press the [VALUE] knob to highlight the character at the cursor location.
- 3 Use the [VALUE] knob to change the character, and then press the [VALUE] knob.

5. When you finish entering the name, use the [VALUE] knob to select “SAVE”, and press the [VALUE] knob.

A confirmation message appears.



* If you decide to cancel, press the [EXIT] button.

6. Use the [VALUE] knob to select “YES”, and press the [VALUE] knob.

This saves the preset file (.V08preset) to the USB flash drive. When the operation is finished, the message “COMPLETE” appears.

7. Press the [MENU] button to close the menu.

Overwrite-saving a file

1. Connect the USB flash drive to the USB MEMORY port.

2. Press the [MENU] button → “PRESET MEMORY” → select “SAVE TO USB MEMORY”, and press the [VALUE] knob.

The preset files on the USB flash drive are shown as a list.

3. Use the [VALUE] knob select the preset file that you want to overwrite, and press the [VALUE] knob.

A confirmation message appears.



* If you decide to cancel, press the [EXIT] button.

4. Use the [VALUE] knob to select “YES”, and press the [VALUE] knob.

The preset file is overwritten. When the operation is finished, the message “COMPLETE” appears.

5. Press the [MENU] button to close the menu.

Loading

Here's how to load the preset memory settings that are saved on a USB flash drive. Doing this overwrites the preset memory (1-24) settings.

1. Press the [MENU] button → “PRESET MEMORY” → select “LOAD FROM USB MEMORY”, and press the [VALUE] knob.



The preset files on the USB flash drive are shown as a list.

2. Use the [VALUE] knob to select the macro settings file that you want to load, and press the [VALUE] knob.

A confirmation message appears.



* If you decide to cancel, press the [EXIT] button.

3. Use the [VALUE] knob to select “YES”, and press the [VALUE] knob.

The preset memory is recalled. When the operation is finished, the message “COMPLETE” appears.

4. Press the [MENU] button to close the menu.

Recording Multiple Operations to Automatically Execute (Macros)

This feature lets you record multiple operations and then automatically execute them (as a macro function). You only need to record the macro operation beforehand and then select the macro to perform the series of operations you recorded. This function is useful for executing exactly the same operations, even when a different operator is using the unit.

You can create up to 100 macros.

Recording a Macro

A single macro can contain up to 10 different operations. You can include a macro within another macro, to make a single macro execute a more complicated set of functions.

* The demo macro data in this unit that's available by factory default includes some recorded operations.

1. Press the [MENU] button → “MACRO” → select “LIST EDIT”, and press the [VALUE] knob.

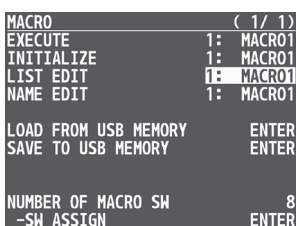

2. Use the [VALUE] knob to select the macro (1–100) you want to edit, and press the [VALUE] knob.

The list of operations recorded in the macro is shown.

3. Use the [VALUE] knob to select “ADD NEW FUNCTION”, and press the [VALUE] knob.

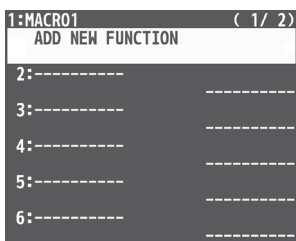

The FUNCTION EDIT menu appears.

4. Use the [VALUE] knob to select “FUNCTION”, and press the [VALUE] knob.

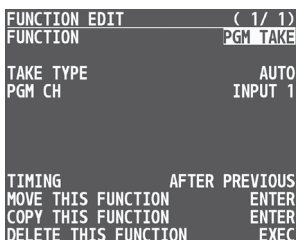

5. Select the operation to record to the macro using the [VALUE] knob, and then press the [VALUE] knob.

* For details on the operations you can record, see “FUNCTION” in “FUNCTION EDIT” (p. 80).

6. Use the [VALUE] knob to set the related menu item.

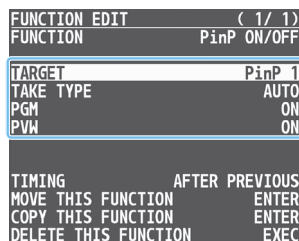

The related menu is shown according to the operation you selected in step 5.

7. Use the [VALUE] knob to select “TIMING”, and press the [VALUE] knob.

8. Use the [VALUE] knob to set the timing at which the operation is executed, and then press the [VALUE] knob.

Value	Explanation
AFTER PREVIOUS	The function is executed after the preceding one. The next sequential list number is used.
SAME AS PREVIOUS	Executes the operation at the same time as the preceding one. The same list number as the previous operation is used.

* If you place a function at the beginning of the macro, setting the timing has no effect.

9. Press the [EXIT] button to return to the previous screen.

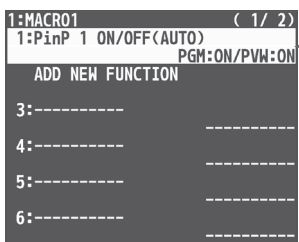

The operation is added to the list.

10. Repeat steps 3–9 to finish making the macro.

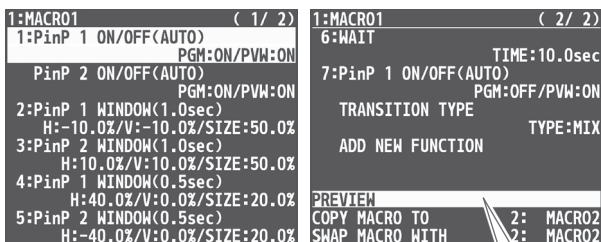

PREVIEW: Press the [VALUE] knob to preview the macro.

11. Press the [MENU] button to close the menu.

Editing a macro

You can edit the contents of a function, change the order in which it is executed, or copy/delete a function either while creating a macro or after the macro is finished.

1. In step 3 of “Renaming a Macro” (p. 50), select the function you want to edit in the list, and press the [VALUE] knob.

```

1:MACRO1 ( 1 / 2 )
1:PinP 1 ON/OFF(AUTO)
   PGM:ON/PVW:ON
   PinP 2 ON/OFF(AUTO)
   PGM:ON/PVW:ON
2:PinP 1 WINDOW(1.0sec)
   H:-10.0%/V:-10.0%/SIZE:50.0%
   PinP 2 WINDOW(1.0sec)
   H:10.0%/V:10.0%/SIZE:50.0%
3:PinP 1 WINDOW(0.5sec)
   H:40.0%/V:0.0%/SIZE:20.0%
4:PinP 2 WINDOW(0.5sec)
   H:-40.0%/V:0.0%/SIZE:20.0%
  
```

The FUNCTION EDIT menu appears.

2. Edit, move, copy or delete the function.

Editing the contents of a function

- 1 Follow steps 4–9 in “Recording a Macro” (p. 46) to edit the contents of the function.

```

FUNCTION EDIT ( 1 / 1 )
FUNCTION PinP WINDOW
TARGET PinP 1
TAKE TIME 0.5sec
POSITION H 40.0%
POSITION V 0.0%
SIZE 20.0%
TIMING AFTER PREVIOUS
MOVE THIS FUNCTION ENTER
COPY THIS FUNCTION ENTER
DELETE THIS FUNCTION EXEC
  
```

Moving a function

- 1 Use the [VALUE] knob to select “MOVE THIS FUNCTION”, and press the [VALUE] knob.

MOVE FUNCTION screen appears.

```

FUNCTION EDIT ( 1 / 1 )
FUNCTION PinP WINDOW
TARGET PinP 1
TAKE TIME 0.5sec
POSITION H 40.0%
POSITION V 0.0%
SIZE 20.0%
TIMING AFTER PREVIOUS
MOVE THIS FUNCTION ENTER
COPY THIS FUNCTION ENTER
DELETE THIS FUNCTION EXEC

MOVE FUNCTION ( 1 / 2 )
1:PinP 1 ON/OFF(AUTO)
   PGM:ON/PVW:ON
   PinP 2 ON/OFF(AUTO)
   PGM:ON/PVW:ON
2:PinP 1 WINDOW(1.0sec)
   H:-10.0%/V:-10.0%/SIZE:50.0%
   PinP 2 WINDOW(1.0sec)
   H:10.0%/V:10.0%/SIZE:50.0%
PinP 1 WINDOW(0.5sec)
   H:40.0%/V:0.0%/SIZE:20.0%
4:PinP 2 WINDOW(0.5sec)
   H:-40.0%/V:0.0%/SIZE:20.0%
  
```

- 2 Use the [VALUE] knob to select where you want to move the function, and then press the [VALUE] knob.

A confirmation message appears.

```

MOVE FUNCTION ( 1 / 2 )
1:PinP 1 ON/OFF(AUTO)
   PGM:ON/PVW:ON
   PinP 2 ON/OFF(AUTO)
   PGM:ON/PVW:ON
PinP 1 WINDOW(0.5sec)
   H:40.0%/V:0.0%/SIZE:20.0%
2:PinP 1 WINDOW(1.0sec)
   H:-10.0%/V:-10.0%/SIZE:50.0%
   PinP 2 WINDOW(1.0sec)
   H:10.0%/V:10.0%/SIZE:50.0%
4:PinP 2 WINDOW(0.5sec)
   H:-40.0%/V:0.0%/SIZE:20.0%

MOVE FUNCTION
ARE YOU SURE? NO YES
  
```

* If you decide to cancel, press the [EXIT] button.

- 3 Use the [VALUE] knob to select “YES”, and press the [VALUE] knob. The function is moved, and the message “COMPLETE” appears.

Copying a function

* Copying is disabled if the number of recorded functions have reached the limit (10).

- 1 Use the [VALUE] knob to select “COPY THIS FUNCTION”, and press the [VALUE] knob.

The COPY FUNCTION screen appears.

```

FUNCTION EDIT ( 1 / 1 )
FUNCTION PinP WINDOW
TARGET PinP 1
TAKE TIME 0.5sec
POSITION H 40.0%
POSITION V 0.0%
SIZE 20.0%
TIMING AFTER PREVIOUS
MOVE THIS FUNCTION ENTER
COPY THIS FUNCTION ENTER
DELETE THIS FUNCTION EXEC

COPY FUNCTION ( 1 / 2 )
1:PinP 1 ON/OFF(AUTO)
   PGM:ON/PVW:ON
   PinP 2 ON/OFF(AUTO)
   PGM:ON/PVW:ON
2:PinP 1 WINDOW(1.0sec)
   H:-10.0%/V:-10.0%/SIZE:50.0%
   PinP 2 WINDOW(1.0sec)
   H:10.0%/V:10.0%/SIZE:50.0%
PinP 1 WINDOW(0.5sec)
   H:40.0%/V:0.0%/SIZE:20.0%
3:PinP 1 WINDOW(0.5sec)
   H:40.0%/V:0.0%/SIZE:20.0%
  
```

- 2 Use the [VALUE] knob to select where you want to copy the function to, and then press the [VALUE] knob.

A confirmation message appears.

```

COPY FUNCTION ( 1 / 2 )
1:PinP 1 ON/OFF(AUTO)
   PGM:ON/PVW:ON
   PinP 2 ON/OFF(AUTO)
   PGM:ON/PVW:ON
PinP 1 WINDOW(0.5sec)
   H:40.0%/V:0.0%/SIZE:20.0%
2:PinP 1 WINDOW(1.0sec)
   H:-10.0%/V:-10.0%/SIZE:50.0%
   PinP 2 WINDOW(1.0sec)
   H:10.0%/V:10.0%/SIZE:50.0%
3:PinP 1 WINDOW(0.5sec)
   H:40.0%/V:0.0%/SIZE:20.0%

COPY FUNCTION
ARE YOU SURE? NO YES
  
```

* If you decide to cancel, press the [EXIT] button.

- 3 Use the [VALUE] knob to select “YES”, and press the [VALUE] knob.

The function is copied, and the message “COMPLETE” appears.

Deleting a function

- 1 Use the [VALUE] knob to select “DELETE THIS FUNCTION”, and press the [VALUE] knob.

A confirmation message appears.

```

FUNCTION EDIT ( 1 / 1 )
FUNCTION PinP WINDOW
TARGET PinP 1
TAKE TIME 0.5sec
POSITION H 40.0%
POSITION V 0.0%
SIZE 20.0%
TIMING AFTER PREVIOUS
MOVE THIS FUNCTION ENTER
COPY THIS FUNCTION ENTER
DELETE THIS FUNCTION EXEC

DELETE FUNCTION
ARE YOU SURE? NO YES
  
```

* If you decide to cancel, press the [EXIT] button.

- 2 Use the [VALUE] knob to select “YES”, and press the [VALUE] knob. The function is deleted, and the message “COMPLETE” appears.

3. Press the [MENU] button to close the menu.

Executing a Macro

Using the buttons (Macro 1–10)

1. Long-press the [MODE] button to make it light up orange.

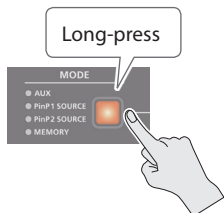

The AUX/PinP SOURCE/MEMORY [1]–[8] buttons function as macro selection buttons.

2. Press the AUX / PinP SOURCE / MEMORY button corresponding to the number of the macro you wish to execute.

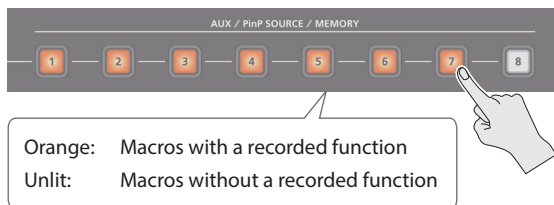

This executes the macro.

Using the menus

1. Press the [MENU] button → “MACRO” → select “EXECUTE”, and press the [VALUE] knob.

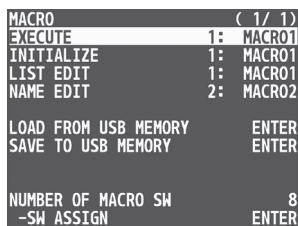

2. Use the [VALUE] knob to select the macro (1–100) that you want to execute, and press the [VALUE] knob.

A confirmation message appears.



* If you decide to cancel, press the [EXIT] button.

3. Use the [VALUE] knob to select “YES”, and press the [VALUE] knob.

The macro is executed.

4. Press the [MENU] button to close the menu.

MEMO

Using the cross-point buttons to select macros

When MODE is macro (the [MODE] button is lit orange), the cross-point buttons function as macro selection buttons.

Use the [MENU] button → “MACRO” → and set “NUMBER OF MACRO SW” to “24”.

Changing the macro assigned to a button

You can change the macros assigned to the buttons.

From the [MENU] button → “MACRO” → “SW ASSIGN”, specify a macro (1–100) to assign to the respective button, using the menu items shown below.

Menu item	Explanation
MACRO 1–8	AUX / PinP SOURCE / MEMORY [1]–[8] buttons
PGM/A 1–8 (*1)	Cross-point A [1]–[8] buttons
PST/B 1–8 (*1)	Cross-point B [1]–[8] buttons

(*1) This can be set if “NUMBER OF MACRO SW” is “24”.

Copying Macro Settings

Here's how to copy the settings from one macro to another.

1. Press the [MENU] button → “MACRO” → select “LIST EDIT”, and press the [VALUE] knob.

```
MACRO ( 1 / 1 )
EXECUTE 1: MACRO1
INITIALIZE 1: MACRO1
LIST EDIT 1: MACRO1
NAME EDIT 1: MACRO1

LOAD FROM USB MEMORY ENTER
SAVE TO USB MEMORY ENTER

NUMBER OF MACRO SW 8
-SW ASSIGN ENTER
```

2. Use the [VALUE] knob to select the copy source macro (1–100), and press the [VALUE] knob.

The list of operations recorded in the macro is shown.

3. Use the [VALUE] knob to select “COPY MACRO TO”, and press the [VALUE] knob.

```
1:MACRO1 ( 2 / 2 )
6:WAIT TIME:10.0sec
7:PinP 1 ON/OFF(AUTO) PGM:OFF/PVW:ON
TRANSITION TYPE TYPE:MIX
ADD NEW FUNCTION

PREVIEW
COPY MACRO TO 2: MACRO2
SWAP MACRO WITH 2: MACRO2
```

4. Use the [VALUE] knob to select the copy destination macro, and then press the [VALUE] knob.

A confirmation message appears.

```
COPY MACRO SETTINGS
ARE YOU SURE? NO YES
```

* If you decide to cancel, press the [EXIT] button.

5. Use the [VALUE] knob to select “YES”, and press the [VALUE] knob.

The macro settings are copied. When the operation is finished, the message “COMPLETE” appears.

6. Press the [MENU] button to close the menu.

Swapping the Macro Settings

Here's how to swap settings between macros.

1. Press the [MENU] button → “MACRO” → select “LIST EDIT”, and press the [VALUE] knob.

```
MACRO ( 1 / 1 )
EXECUTE 1: MACRO1
INITIALIZE 1: MACRO1
LIST EDIT 1: MACRO1
NAME EDIT 1: MACRO1

LOAD FROM USB MEMORY ENTER
SAVE TO USB MEMORY ENTER

NUMBER OF MACRO SW 8
-SW ASSIGN ENTER
```

2. Use the [VALUE] knob to select the swap source macro (1–100), and press the [VALUE] knob.

The list of operations recorded in the macro is shown.

3. Use the [VALUE] knob to select “SWAP MACRO WITH”, and press the [VALUE] knob.

```
1:MACRO1 ( 2 / 2 )
6:WAIT TIME:10.0sec
7:PinP 1 ON/OFF(AUTO) PGM:OFF/PVW:ON
TRANSITION TYPE TYPE:MIX
ADD NEW FUNCTION

PREVIEW
COPY MACRO TO 2: MACRO2
SWAP MACRO WITH 2: MACRO2
```

4. Use the [VALUE] knob to select the swap destination macro, and press the [VALUE] knob.

A confirmation message appears.

```
SWAP MACRO SETTINGS
ARE YOU SURE? NO YES
```

* If you decide to cancel, press the [EXIT] button.

5. Use the [VALUE] knob to select “YES”, and press the [VALUE] knob.

This swaps the settings of the macros. When the operation is finished, the message “COMPLETE” appears.

6. Press the [MENU] button to close the menu.

Initializing a Macro

You can initialize a macro and completely erase its settings.

1. Press the [MENU] button → “MACRO” → select “INITIALIZE”, and press the [VALUE] knob.

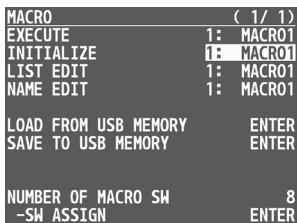

2. Use the [VALUE] knob to the macro you wish to select (ALL, 1–100), and press the [VALUE] knob.

A confirmation message appears.



* If you decide to cancel, press the [EXIT] button.

3. Use the [VALUE] knob to select “YES”, and press the [VALUE] knob.

The macro is initialized. When the operation is finished, the message “COMPLETE” appears.

4. Press the [MENU] button to close the menu.

MEMO
About the macro demo data
 Once you perform a factory reset (p. 64), any demo data you have edited or deleted is restored to its factory default settings.

Renaming a Macro

Here’s how to rename a macro.

1. Press the [MENU] button → “MACRO” → select “NAME EDIT”, and press the [VALUE] knob.



2. Use the [VALUE] knob to select the macro (1–100) that you want to rename, and then press the [VALUE] knob.

The MACRO NAME EDIT screen appears.

3. Input the macro name.

* You can input up to 8 characters.

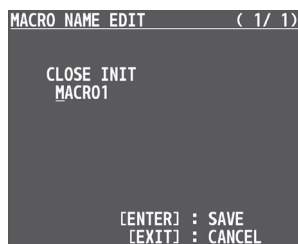

INIT: Initializes the name.

1. Use the [VALUE] knob to move the cursor.

Pressing the [EXIT] button deletes the character at the cursor location.

2. Press the [VALUE] knob to highlight the character at the cursor location.

3. Use the [VALUE] knob to change the character, and then press the [VALUE] knob.

4. When you have finished inputting the name, use the [VALUE] knob to select “CLOSE”, and then press the [VALUE] knob.

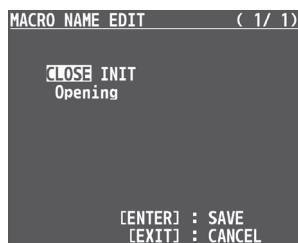

* If you decide to cancel, press the [EXIT] button.

5. Press the [MENU] button to close the menu.

Saving/Loading the Macro Settings

You can group together the macro settings (1–100) into a single file (.RMC) and save it to a USB flash drive connected to the USB MEMORY port. You can access the saved macro setting file on the USB flash drive and load it into the unit for use when needed.

NOTE

- When using a USB flash drive for the first time, you must format it using the V-8HD (p. 60).
- Depending on the USB flash drive, recognition of the flash drive might take some time.

Saving

Saving a new file

1. Connect the USB flash drive to the USB MEMORY port.
2. Press the [MENU] button → “MACRO” → select “SAVE TO USB MEMORY”, and press the [VALUE] knob.

```
MACRO ( 1 / 1)
EXECUTE 1: MACRO1
INITIALIZE 1: MACRO1
LIST EDIT 1: MACRO1
NAME EDIT 1: MACRO1

LOAD FROM USB MEMORY ENTER
SAVE TO USB MEMORY ENTER

NUMBER OF MACRO SW 8
-SW ASSIGN ENTER
```

The macro setting files in the USB flash drive are listed.

3. Use the [VALUE] knob to select “NEW FILE...”, and press the [VALUE] knob.

```
SAVE MACRO DATA ( 1 / 1)
NEW FILE...

[ENTER] : ENTER
[EXIT] : EXIT
```

4. Enter the file name.

* You can enter a text string of up to 16 characters in length.

```
SAVE MACRO DATA ( 1 / 1)

SAVE EXIT
MACRO_DATA_0000 .RMC

[ENTER] : EDIT
[EXIT] : DELETE
```

- 1 Use the [VALUE] knob to move the cursor.
Pressing the [EXIT] button deletes the character at the cursor location.
- 2 Press the [VALUE] knob to highlight the character at the cursor location.
- 3 Use the [VALUE] knob to change the character, and then press the [VALUE] knob.

5. When you finish entering the name, use the [VALUE] knob to select “SAVE”, and press the [VALUE] knob.

A confirmation message appears.

```
SAVE MACRO DATA ( 1 / 1)

SAVE EXIT
MACRO_Settings01.RMC

[ENTER] : SAVE
[EXIT] : EXIT
```

```
SAVE MACRO_settings0
ARE YOU SURE?
YES
```

* If you decide to cancel, press the [EXIT] button.

6. Use the [VALUE] knob to select “YES”, and press the [VALUE] knob.

The macro settings file (.RMC) is saved to the USB flash drive. When the operation is finished, the message “COMPLETE” appears.

7. Press the [MENU] button to close the menu.

Overwrite-saving a file

1. Connect the USB flash drive to the USB MEMORY port.
2. Press the [MENU] button → “MACRO” → select “SAVE TO USB MEMORY”, and press the [VALUE] knob.

The macro setting files in the USB flash drive are listed.

3. Use the [VALUE] knob select the macro settings file that you want to overwrite, and press the [VALUE] knob.

A confirmation message appears.

```
SAVE MACRO DATA ( 1 / 1)
1:MACRO_Settings01.RMC
2:MACRO_Settings02.RMC
NEW FILE...

[ENTER] : OVERWRITE
[EXIT] : EXIT
```

```
SAVE MACRO_settings0
ARE YOU SURE?
YES
```

* If you decide to cancel, press the [EXIT] button.

4. Use the [VALUE] knob to select “YES”, and press the [VALUE] knob.

The macro settings file is overwritten. When the operation is finished, the message “COMPLETE” appears.

5. Press the [MENU] button to close the menu.

Loading

Here's how to load the macro settings that are saved on a USB flash drive. Loading the settings overwrites the current settings for the macros (1–100).

1. Press the [MENU] button → “MACRO” → select “LOAD FROM USB MEMORY”, and press the [VALUE] knob.

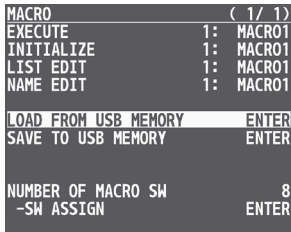

The macro setting files in the USB flash drive are listed.

2. Use the [VALUE] knob to select the macro settings file that you want to load, and press the [VALUE] knob.

A confirmation message appears.

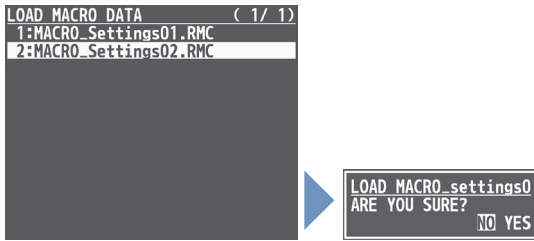

* If you decide to cancel, press the [EXIT] button.

3. Use the [VALUE] knob to select “YES”, and press the [VALUE] knob.

The macro settings are loaded. When the operation is finished, the message “COMPLETE” appears.

4. Press the [MENU] button to close the menu.

Combining Preset Memories and Macros for Operations (Sequencer)

The sequencer function lets you record functions such as recalling preset memories or macros, and then execute them in the order you specify. This lets you recreate the desired functions like editing the screen layout or inserting a title, by preparing the functions in line with how the events progress and then simply pressing the [AUTO] button. This feature is useful for smoothly carrying out operations at the place where you're working.

Recording to the Sequencer

Three types of functions can be recorded in the sequencer, including recalling a preset memory, executing a macro and switching between final output videos. Create a list of the functions you want to execute in order.

A list can contain up to 1,000 functions.

MEMO

The demo data in this unit that's available by factory default includes a list of recorded functions. You can completely erase the contents of this list by initializing it (p. 58).

1. Press the [MENU] button → "SEQUENCER" → select "LIST EDIT", and press the [VALUE] knob.

```
SEQUENCER ( 1 / 1 )
SEQUENCER OFF
-REPEAT EXECUTE ON
-AUTO SEQUENCE ---
LIST EDIT ENTER
INITIALIZE EXEC
LOAD FROM USB MEMORY ENTER
SAVE TO USB MEMORY ENTER
```

The list of operations recorded in the sequencer is shown.

2. Use the [VALUE] knob to select "ADD NEW FUNCTION", and press the [VALUE] knob.

```
LIST EDIT ( 1 / 1 )
ADD NEW FUNCTION
```

The FUNCTION EDIT menu appears.

3. Use the [VALUE] knob to select "FUNCTION", and press the [VALUE] knob.

```
FUNCTION EDIT ( 1 / 1 )
FUNCTION PGM TAKE
-PGM CH INPUT 1

NAME INPUT 1
-EDIT AUTO
AUTO SEQUENCE 5sec

MOVE THIS FUNCTION
COPY THIS FUNCTION
DELETE THIS FUNCTION
```

4. Use the [VALUE] knob to select the function to record to the sequencer, and then press the [VALUE] knob.

Value	Explanation
PGM TAKE	Switches the final output video.
PRESET MEMORY	Recalls a preset memory.
MACRO	Executes a macro.

5. Use the [VALUE] knob to set the related menu item.

```
FUNCTION EDIT ( 1 / 1 )
FUNCTION PRESET MEMORY
-LOAD 1: MEMORY1

NAME MEMORY1
-EDIT AUTO
AUTO SEQUENCE 5sec

MOVE THIS FUNCTION
COPY THIS FUNCTION
DELETE THIS FUNCTION
```

The related menu is shown according to the operation you selected in step 4.

6. Press the [EXIT] button to return to the previous screen.

```
LIST EDIT ( 1 / 1 )
1:MEMORY1 5sec
ADD NEW FUNCTION
```

The operation is added to the list.

7. Repeat steps 2–6 to finish making the list.

```
LIST EDIT ( 1 / 1 )
1:MEMORY1 5sec
2:MACRO1 5sec
3:MACRO10 5sec
4:MEMORY3 5sec
5:MACRO3 5sec
6:MACRO4 5sec
7:MACRO7 5sec
8:DEMO 8 5sec
ADD NEW FUNCTION
```

8. Press the [MENU] button to close the menu.

Editing a list

You can edit the contents of a function, change the order in which it is executed, or copy/delete a function while creating a list or after you've finished the list.

- In step 2 of "Recording to the Sequencer" (p. 53), select the function you want to edit in the list, and press the [VALUE] knob.

LIST EDIT (1 / 1)	
1:MEMORY2	5sec
2:MACRO1	5sec
3:MEMORY3	5sec
4:MACRO3	5sec
5:MACRO4	5sec
6:MACRO7	5sec
7:MACRO8	5sec
8:MACRO20	5sec
ADD NEW FUNCTION	

The FUNCTION EDIT menu appears.

- Edit, move, copy or delete the function.

Editing the contents of a function

- Follow steps 3–6 in "Recording to the Sequencer" (p. 53) to edit the contents of the function.

FUNCTION EDIT (1 / 1)	
FUNCTION	PRESET MEMORY
-LOAD	3: MEMORY3
NAME MEMORY3	
-EDIT	AUTO
AUTO SEQUENCE	5sec
MOVE THIS FUNCTION	
COPY THIS FUNCTION	
DELETE THIS FUNCTION	

Moving a function

- Use the [VALUE] knob to select "MOVE THIS FUNCTION"; and press the [VALUE] knob.

The MOVE FUNCTION screen appears.

FUNCTION EDIT (1 / 1)		MOVE FUNCTION (1 / 1)	
FUNCTION	PRESET MEMORY	1:MEMORY2	5sec
-LOAD	3: MEMORY3	2:MACRO1	5sec
NAME MEMORY3		MEMORY3	5sec
-EDIT	AUTO	4:MACRO3	5sec
AUTO SEQUENCE	5sec	5:MACRO4	5sec
MOVE THIS FUNCTION		6:MACRO7	5sec
COPY THIS FUNCTION		7:MACRO8	5sec
DELETE THIS FUNCTION		8:MACRO20	5sec

- Use the [VALUE] knob to select where you want to move the function, and then press the [VALUE] knob.

A confirmation message appears.

MOVE FUNCTION (1 / 1)	
1:MEMORY2	5sec
2:MACRO1	5sec
4:MACRO3	5sec
5:MACRO4	5sec
6:MACRO7	5sec
MEMORY3	5sec
7:MACRO8	5sec
8:MACRO20	5sec

MOVE FUNCTION	ARE YOU SURE?	NO	YES
---------------	---------------	----	-----

* If you decide to cancel, press the [EXIT] button.

- Use the [VALUE] knob to select "YES"; and press the [VALUE] knob.

The function is moved, and the message "COMPLETE" appears.

Copying a function

- Use the [VALUE] knob to select "COPY THIS FUNCTION", and press the [VALUE] knob.

The COPY FUNCTION screen appears.

FUNCTION EDIT (1 / 1)		COPY FUNCTION (1 / 1)	
FUNCTION	PRESET MEMORY	1:MEMORY2	5sec
-LOAD	3: MEMORY3	2:MACRO1	5sec
NAME MEMORY3		MEMORY3	5sec
-EDIT	AUTO	4:MACRO3	5sec
AUTO SEQUENCE	5sec	5:MACRO4	5sec
MOVE THIS FUNCTION		6:MACRO7	5sec
COPY THIS FUNCTION		7:MACRO8	5sec
DELETE THIS FUNCTION		8:MACRO20	5sec

- Use the [VALUE] knob to select where you want to copy the function to, and then press the [VALUE] knob.

A confirmation message appears.

COPY FUNCTION (1 / 1)	
1:MEMORY2	5sec
2:MACRO1	5sec
3:MEMORY3	5sec
4:MACRO3	5sec
5:MACRO4	5sec
MEMORY3	5sec
6:MACRO7	5sec
7:MACRO8	5sec
8:MACRO20	5sec

COPY FUNCTION	ARE YOU SURE?	NO	YES
---------------	---------------	----	-----

* If you decide to cancel, press the [EXIT] button.

- Use the [VALUE] knob to select "YES"; and press the [VALUE] knob.

The function is copied, and the message "COMPLETE" appears.

Deleting a function

- Use the [VALUE] knob to select "DELETE THIS FUNCTION"; and press the [VALUE] knob.

A confirmation message appears.

FUNCTION EDIT (1 / 1)	
FUNCTION	PRESET MEMORY
-LOAD	3: MEMORY3
NAME MEMORY3	
-EDIT	AUTO
AUTO SEQUENCE	5sec
MOVE THIS FUNCTION	
COPY THIS FUNCTION	
DELETE THIS FUNCTION	

DELETE FUNCTION	ARE YOU SURE?	NO	YES
-----------------	---------------	----	-----

* If you decide to cancel, press the [EXIT] button.

- Use the [VALUE] knob to select "YES"; and press the [VALUE] knob.

The function is deleted, and the message "COMPLETE" appears.

- Press the [MENU] button to close the menu.

Running the Sequencer

Press the button to make the functions recorded in the sequencer execute one at a time.

1. Press the [MENU] button → “SEQUENCER” → select “SEQUENCER”, and press the [VALUE] knob.

```

SEQUENCER ( 1 / 1 )
SEQUENCER OFF
-REPEAT EXECUTE ON
-AUTO SEQUENCE ---
LIST EDIT ENTER
INITIALIZE EXEC
LOAD FROM USB MEMORY ENTER
SAVE TO USB MEMORY ENTER
  
```

2. Use the [VALUE] knob to select “ON”, and press the [VALUE] knob.

The sequencer function turns on.

3. Press the [MENU] button to close the menu.

The list of operations recorded in the sequencer is shown.

```

SEQUENCER ( 1 / 2 )
CURRENT
START
NEXT
START (CURRENT)
1: MEMORY 1 5sec
2: MACRO1 5sec
3: MACRO10 5sec
4: MEMORY3 5sec
5: MACRO3 5sec
6: MACRO4 5sec
7: MACRO7 5sec
  
```

4. Press the [AUTO] button.

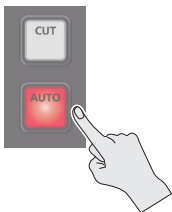

The first function in the list is executed.

The button blinks while the function is executing. When the function ends, the button remains lit.

5. Press the [AUTO] button at the timing when you want the next function to execute.

The function is executed.

[CUT] button

Press the [CUT] button if you want to return to the state at which the previous function was completed.

6. Repeat step 5.

7. To turn the sequencer function off, use the [MENU] button → “SEQUENCER” → and set “SEQUENCER” to “OFF”.

8. Press the [MENU] button to close the menu.

MEMO

Repeatedly executing a function in the list

You can repeatedly execute functions that are in a list. Once the last function is finished, press the [AUTO] button to execute the function at the beginning of the list.

Use the [MENU] button → “SEQUENCER” → and set “REPEAT EXECUTE” to “ON”.

Executing a function from the middle of the list

Use the [VALUE] knob to select a function from the list, and then press the [VALUE] knob to set the selected function to its completed state. You can press the [AUTO] button to execute the next function afterwards.

Using the USER buttons

You can assign the function to a USER button and turn sequencer on/off.

Use the [MENU] button → “SYSTEM” → “USER SW 1” or “UESR SW 2” → use the following menu items to change the function assignment.

Menu item	Explanation
CATEGORY	Choose “SEQUENCER”.
VALUE	Choose “MODE ON/OFF”.

Making the Sequencer Run Automatically (Auto Sequence)

Use the auto sequence feature when you want to make the functions recorded in the sequencer execute automatically.

Configuring the auto sequence settings

Set the action or function that's executed when the sequencer advances to the next function. You can add some delay time before the next function is executed, or pause the execution of a function.

1. Press the [MENU] button → "SEQUENCER" → select "LIST EDIT", and press the [VALUE] knob.

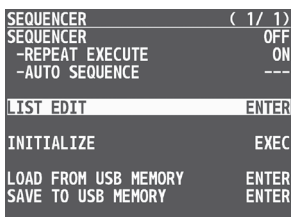

The list of operations recorded in the sequencer is shown.

2. Select the function in the list, and press the [VALUE] knob.

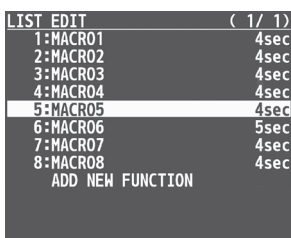

The FUNCTION EDIT menu appears.

3. Use the [VALUE] knob to select "AUTO SEQUENCE", and press the [VALUE] knob.

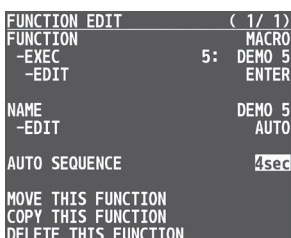

4. Use the [VALUE] knob to set the action that's executed when the sequencer advances to the next function, and then press the [VALUE] knob.

Value	Explanation
PAUSE	Pauses the auto sequence.
AUTO	Executes the next operation in the sequence.
1-120sec	Executes the next operation after delaying for a specified amount of time.

5. Press the [MENU] button to close the menu.

Running the auto sequence

1. Use the [MENU] button → "SEQUENCER" → and set "SEQUENCER" to "ON".

The sequencer function turns on.

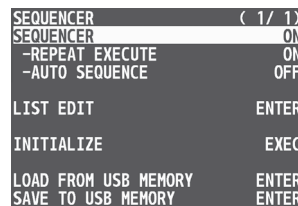

2. Use the [VALUE] knob to select "AUTO SEQUENCE", and set it to "ON".

The auto sequence turns on, and the functions in the list are executed, starting at the beginning. The [AUTO] button blinks while a function is executing.

When the last function is finished, the sequence stops automatically.

When a function is set to "PAUSE"

When the function is finished, auto sequence is paused. You can press the [AUTO] button to manually execute the next function.

- * When executing a function that's set to a value other than "PAUSE", the auto sequence is resumed.

3. To turn the auto sequence off, set "AUTO SEQUENCE" to "OFF".

4. Press the [MENU] button to close the menu.

MEMO

- You can repeatedly execute functions that are in a list. When the last function is finished, the sequencer returns to the beginning.
Use the [MENU] button → "SEQUENCER" → and set "REPEAT EXECUTE" to "ON".
- The list of operations recorded in the sequencer are shown when you turn the auto sequence (mentioned in step 2) on and close the menu. This lets you check which action is executed when the sequencer moves to the next function.

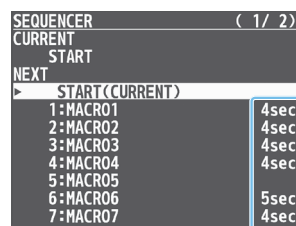

When the action is set to "PAUSE", this is blank.

- You can assign the function to a USER button and turn auto sequence on/off (p. 63).

Saving/Loading the Sequencer Settings

You can save the sequencer settings as a single file (.RSQ) to a USB flash drive connected to the USB MEMORY port. You can access the saved sequence file on the USB flash drive and load it into the unit for use when needed.

NOTE

- When using a USB flash drive for the first time, you must format it using the V-8HD (p. 60).
- Depending on the USB flash drive, recognition of the flash drive might take some time.

Saving

Saving a new file

1. Connect the USB flash drive to the USB MEMORY port.
2. Press the [MENU] button → “SEQUENCER” → select “SAVE TO USB MEMORY”, and press the [VALUE] knob.

```

SEQUENCER ( 1 / 1 )
SEQUENCER OFF
-REPEAT EXECUTE ON
-AUTO SEQUENCE ---

LIST EDIT ENTER
INITIALIZE EXEC

LOAD FROM USB MEMORY ENTER
SAVE TO USB MEMORY ENTER
  
```

The sequence files in the USB flash drive are listed.

3. Use the [VALUE] knob to select “NEW FILE...”, and press the [VALUE] knob.

```

SAVE SEQUENCER DATA ( 1 / 1 )
NEW FILE...

[ENTER] : ENTER
[EXIT] : EXIT
  
```

4. Enter the file name.

* You can enter a text string of up to 16 characters in length.

```

SAVE SEQUENCER DATA ( 1 / 1 )
SAVE EXIT
SEQ_DATA_0000 .RSQ

[ENTER] : EDIT
[EXIT] : DELETE
  
```

- 1 Use the [VALUE] knob to move the cursor.
Pressing the [EXIT] button deletes the character at the cursor location.
- 2 Press the [VALUE] knob to highlight the character at the cursor location.
- 3 Use the [VALUE] knob to change the character, and then press the [VALUE] knob.

5. When you finish entering the name, use the [VALUE] knob to select “SAVE”, and press the [VALUE] knob.

A confirmation message appears.

```

SAVE SEQUENCER DATA ( 1 / 1 )
SAVE EXIT
SEQ_Live001 .RSQ

[ENTER] : SAVE
[EXIT] : EXIT
  
```

```

SAVE_SEQ_Live001.RSQ
ARE YOU SURE?
NO YES
  
```

* If you decide to cancel, press the [EXIT] button.

6. Use the [VALUE] knob to select “YES”, and press the [VALUE] knob.

The sequence file (.RSQ) is saved to the USB flash drive. When the operation is finished, the message “COMPLETE” appears.

7. Press the [MENU] button to close the menu.

Overwrite-saving

1. Connect the USB flash drive to the USB MEMORY port.
2. Press the [MENU] button → “SEQUENCER” → select “SAVE TO USB MEMORY”, and press the [VALUE] knob.
The sequence files in the USB flash drive are listed.
3. Use the [VALUE] knob select the sequence file that you want to overwrite, and press the [VALUE] knob.
A confirmation message appears.

```

SAVE SEQUENCER DATA ( 1 / 1 )
1:SEQ_Live001.RSQ
2:SEQ_Show01.RSQ
NEW FILE...

[ENTER] : OVERWRITE
[EXIT] : EXIT
  
```

```

SAVE_SEQ_Show01.RSQ
ARE YOU SURE?
NO YES
  
```

* If you decide to cancel, press the [EXIT] button.

4. Use the [VALUE] knob to select “YES”, and press the [VALUE] knob.
The sequence file is overwritten. When the operation is finished, the message “COMPLETE” appears.
5. Press the [MENU] button to close the menu.

Loading

Here's how to load the sequencer settings that are saved on a USB flash drive. When you load settings, the current sequencer settings are overwritten.

1. Press the [MENU] button → "SEQUENCER" → select "LOAD FROM USB MEMORY", and press the [VALUE] knob.

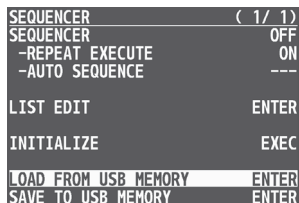

The sequence files in the USB flash drive are listed.

2. Use the [VALUE] knob to select the sequence file that you want to load, and press the [VALUE] knob.

A confirmation message appears.



* If you decide to cancel, press the [EXIT] button.

3. Use the [VALUE] knob to select "YES", and press the [VALUE] knob.

The sequencer settings are loaded. When the operation is finished, the message "COMPLETE" appears.

4. Press the [MENU] button to close the menu.

Initializing the Sequencer

Here's how to initialize the sequencer and erase all the settings.

1. Press the [MENU] button → "SEQUENCER" → select "INITIALIZE", and press the [VALUE] knob.

A confirmation message appears.

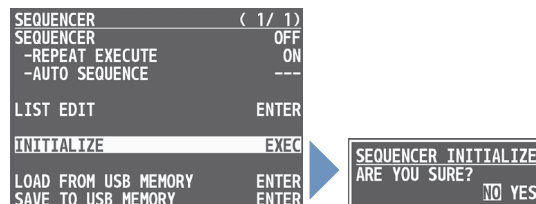

* If you decide to cancel, press the [EXIT] button.

2. Use the [VALUE] knob to select "YES", and press the [VALUE] knob.

The sequencer is initialized. When the operation is finished, the message "COMPLETE" appears.

3. Press the [MENU] button to close the menu.

MEMO

About the sequencer demo data

Once you perform a factory reset (p. 64), any demo data you have edited or deleted is restored to its factory default settings.

Saving the Unit's Settings on a USB Flash Drive

You can group together the unit's settings into a single file (.V08) and save it to a USB flash drive connected to the USB MEMORY port. You can access the saved file (.V08) on the USB flash drive and load it into the unit for use when needed.

NOTE

- When you're using a USB flash drive for the first time, be sure to format it on the V-8HD (p. 60).
- Depending on the USB flash drive, recognition of the flash drive might take some time.

Saving

Saving a new settings file

1. Press the [MENU] button → "USB MEMORY" → select "BACKUP ALL SETTINGS", and press the [VALUE] knob.

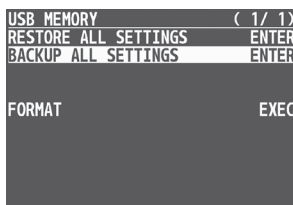

2. Use the [VALUE] knob to select "NEW FILE...," and press the [VALUE] knob.



3. Enter the file name.

* You can enter a text string of up to 16 characters in length.

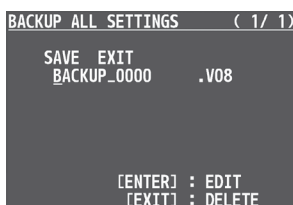

- 1 Use the [VALUE] knob to move the cursor.
Pressing the [EXIT] button deletes the character at the cursor location.
- 2 Press the [VALUE] knob to highlight the character at the cursor location.
- 3 Use the [VALUE] knob to change the character, and then press the [VALUE] knob.

4. When you finish entering the name, turn the [VALUE] knob to select "SAVE", and press the [VALUE] knob.

A confirmation message appears.



* If you decide to cancel, press the [EXIT] button.

5. Press the [VALUE] knob.

The file (.V08) is newly saved on the USB flash drive.

6. Press the [MENU] button to quit the menu.

Overwrite-saving a settings file

1. Press the [MENU] button → "USB MEMORY" → select "BACKUP ALL SETTINGS", and press the [VALUE] knob.



2. Use the [VALUE] knob select the file to overwrite, and press the [VALUE] knob.

A confirmation message appears.



* If you decide to cancel, press the [EXIT] button.

* If you long-press the [VALUE] knob, the edit screen opens with the file name preserved.

3. Press the [VALUE] knob.

The file (.V08) is newly saved on the USB flash drive.

4. Press the [MENU] button to quit the menu.

Recalling

This loads settings that are in a preset memory saved on a USB flash drive. Loading settings overwrites the preset memory on the unit.

1. Press the [MENU] button → “USB MEMORY” → select “RESTORE ALL SETTINGS”, and press the [VALUE] knob.

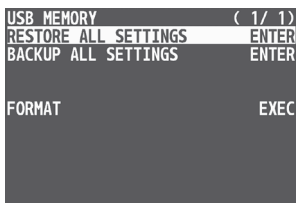

2. Use the [VALUE] knob to select the file you want to recall, and press the [VALUE] knob.

A confirmation message appears.



* If you decide to cancel, press the [EXIT] button.

3. Use the [VALUE] knob to select “YES”, and press the [VALUE] knob.

The settings are recalled, and the values in the unit’s preset memories are overwritten.

4. Press the [MENU] button to quit the menu.

Formatting USB Flash Drives

When using a USB flash drive for the first time, be sure to format it on the V-8HD.

NOTE

- You may not be able to normally use USB flash drives on the V-8HD that are formatted on a different device. Be sure to format the media on the V-8HD (in FAT32 format).
- * Depending on the original format, formatting the USB flash drive might take some time. If an error message like “USB memory not ready” is shown, format the media on the V-8HD so that you can use it.
- Performing formatting causes all data already saved on the USB flash drive to be deleted. If the ash drive contains necessary data, back it up onto a computer or elsewhere before formatting the drive.

1. Connect the USB flash drive to the USB MEMORY port.

2. Press the [MENU] button → “USB MEMORY” → select “FORMAT”, and press the [VALUE] knob.

A confirmation message appears.

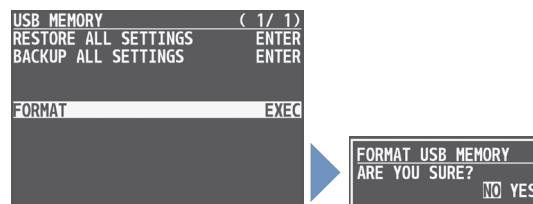

* If you decide to cancel, press the [EXIT] button.

3. Use the [VALUE] knob to select “YES”, and press the [VALUE] knob.

Formatting of the USB flash drive is carried out.

4. Press the [MENU] button to quit the menu.

Using a Footswitch

You can use a footswitch connected to the CTL/EXP 1, 2 jacks of the V-8HD to control the V-8HD with your foot.

You can assign various functions to the footswitch.

1. Connect a footswitch as described in p. 5.
2. Press the [MENU] button → “CTL/EXP” → “CTL/EXP 1” or “CTL/EXP 2” → select “CTL/EXP TYPE”, and press the [VALUE] knob.

CTL/EXP 1	(1 / 1)
CTL/EXP TYPE	OFF
ASSIGN	
-CTL A	
-CATEGORY	---
-VALUE	---
-CTL B	
-CATEGORY	---
-VALUE	---
-EXP	
-CATEGORY	---
-VALUE	---
EXP CALIBRATE	---

3. Use the [VALUE] knob to select “CTL A & CTL B”, and press the [VALUE] knob.
4. Use the [VALUE] knob to select CTL A or CTL B “CATEGORY” and “VALUE”, and press the [VALUE] knob.

CTL/EXP 1	(1 / 1)
CTL/EXP TYPE	CTL A & CTL B
ASSIGN	
-CTL A	
-CATEGORY	A/PGM CH SELECT
-VALUE	INPUT 1
-CTL B	
-CATEGORY	N/A
-VALUE	---
-EXP	
-CATEGORY	---
-VALUE	---
EXP CALIBRATE	---

5. Use the [VALUE] knob to select the function that you want to assign to CTL A or CTL B of the footswitch, and press the [VALUE] knob.

CATEGORY

Value	Explanation
N/A	No function is assigned.
PGM CH SELECT	Switches the video sent to the A/PGM bus.
PST CH SELECT	Switches the video sent to the B/PST bus.
AUX CH SELECT	Switches the video sent to the AUX bus.
INPUT 1-8 ASSIGN	Each time you press the footswitch, the video source of the specified input channel switches.
STILL OUTPUT	Pauses the normal output, and preview/final outputs a cut of the still image.
PinP 1, 2 SOURCE	Switches the video source of the inset screen.
DSK SOURCE	Switches the DSK video source.
SW CONTROL	This works the same as when you press the button selected in “VALUE”.
TAKE	Switches the video between A/PGM bus and B/PST bus.
AUDIO INPUT MUTE	Turns the mute function on/off for the input audio.
AUDIO OUTPUT MUTE	Turns the mute function on/off for the output audio.
AUDIO INPUT SOLO	Turns the solo function on/off for the input audio.
OUTPUT FADE	The same function as turning the [OUTPUT FADE] knob.

Value	Explanation
LOAD MEMORY	Recalls a preset memory.
INPUT SCAN	Each time you press the footswitch, the INPUT 1-8 video changes in order.
MEMORY SCAN	Each time you press the footswitch, preset memories 1-24 are recalled in order.
MACRO EXECUTE	Executes a macro (a series of recorded operations).
SEQUENCER	MODE ON/OFF: Turns sequencer function on/off.
	NEXT: When the sequencer function is on, the same operation as when you press the [AUTO] button.
	PREVIOUS: When the sequencer function is on, the same operation as when you press the [CUT] button.
	AUTO SEQUENCE: Turns the auto sequence function on/off.

VALUE

Configures the detailed settings related to “CATEGORY”.

6. Press the [MENU] button to quit the menu.

Using an Expression Pedal

You can use an expression pedal connected to the CTL/EXP 1, 2 jacks of the V-8HD to control the V-8HD with your foot.

Adjusting the pedal (pedal calibration)

The first time you use an expression pedal, you must calibrate (adjust) the pedal so that it will operate optimally.

In some cases, an expression pedal might no longer operate optimally due to the passage of time or changes in the operating conditions. If you notice problems such as slight movements of the pedal causing a major change in volume, or if the video fails to switch when you press the pedal, you should execute calibration.

1. Press the [MENU] button → “CTL/EXP” → “CTL/EXP 1” or “CTL/EXP 2” → select “CTL/EXP TYPE”, and press the [VALUE] knob.

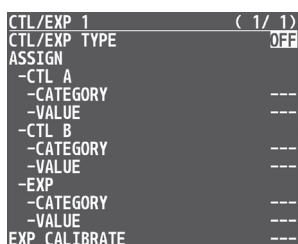

2. Use the [VALUE] knob to select “EXP”, and press the [VALUE] knob.

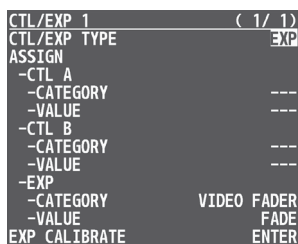

3. Use the [VALUE] knob to select “EXP CALIBRATE”, and press the [VALUE] knob.

The EXP CALIBRATE screen appears.

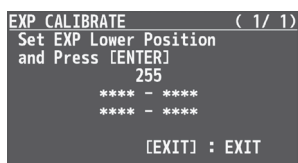

4. As directed by the screen, step on the pedal in the fully heel-down position, and press the [VALUE] knob.
5. As directed by the screen, step on the pedal in the fully toe-down position, and press the [VALUE] knob.
When the “Complete” indication appears, calibration is completed.
6. Press the [MENU] button to quit the menu.

MEMO

You should normally use the EV-5 with its minimum volume knob left in the zero position.
If you change the position of the minimum volume knob, you must execute pedal calibration.

Assigning a function to the pedal

A variety of functions can be assigned to the expression pedal.

1. Press the [MENU] button → “CTL/EXP” → “CTL/EXP 1” or “CTL/EXP 2”, → select “CTL/EXP TYPE”, and press the [VALUE] knob.
2. Use the [VALUE] knob to select “EXP”, and press the [VALUE] knob.
3. Use the [VALUE] knob to select EXP “CATEGORY” and “VALUE”, and press the [VALUE] knob.

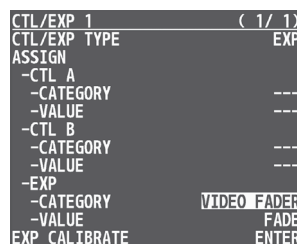

4. Use the [VALUE] knob to select the function that you want to assign to the expression pedal, and press the [VALUE] knob.

CATEGORY

Value	Explanation
N/A	No function is assigned.
VIDEO FADER	FADE: Operates the video fader. ▲ CUT ▼: Switches the video between A/PGM bus and B/PST bus as a cut.
VFX MIX LEVEL	Adjusts the density (output level) of the video that is processed by the visual effect.
OUTPUT FADE	The same function as turning the [OUTPUT FADE] knob.
STILL OUTPUT	Pauses the normal output, and preview/final outputs a cut of the still image.
AUDIO INPUT LEVEL	Adjusts the input volume.
AUDIO OUTPUT LEVEL	Adjusts the output volume.

VALUE

Configures the detailed settings related to “CATEGORY”.

5. Press the [MENU] button to quit the menu.

Assigning the Functions of the USER [1] [2] Buttons

* With the factory settings, the freeze function is assigned to the USER [1] button and the auto switching function is assigned to the USER [2] button.

1. Press the [MENU] button → “SYSTEM” → select USER 1 SW or USER 2 SW “CATEGORY” and “VALUE”, and press the [VALUE] knob.

```

SYSTEM ( 2 / 4 )
OUTPUT FADE ASSIGN
-TURN LEFT STILL 8 OUTPUT
-TURN RIGHT WHITE&AUDIO
USER 1 SW
-CATEGORY FREEZE
-VALUE ---
USER 2 SW
-CATEGORY AUTO SWITCHING
-VALUE AUTO SWITCHING SW
LED DIMMER 8
LCD DIMMER 8
  
```

2. Use the [VALUE] knob to select the function that you want to assign to the USER [1] or [2] button, and then press the [VALUE] knob.

CATEGORY

Value	Explanation
N/A	No function is assigned.
FREEZE	Turns the freeze function on/off.
AUTO SWITCHING	AUTO SWITCHING SW: Turns the auto switching function on/off.
BPM TAP	BPM TAP: If AUTO SWITCHING is “BPM SYNC”, you can set the BPM according to the tempo at which you press the button.
INPUT ASSIGN	Each time you press a button, the video source of the specified input channel switches.
STILL OUTPUT	Pauses the normal output, and preview/final outputs a cut of the still image.
AUDIO INPUT MUTE	Turns the mute function on/off for the input audio.
AUDIO OUTPUT MUTE	Turns the mute function on/off for the output audio.
INPUT SCAN	Each time you press a button, the INPUT 1–8 video changes in order.
MEMORY SCAN	Each time you press a button, preset memories 1–24 are recalled in order.
REC CONTROL	Controls the recorder’s video record start/stop if a recorder that supports HDMI REC TRIGGER functionality is connected.
SEQUENCER	MODE ON/OFF: Turns sequencer function on/off.
	NEXT: When the sequencer function is on, the same operation as when you press the [AUTO] button.
	PREVIOUS: When the sequencer function is on, the same operation as when you press the [CUT] button.
	AUTO SEQUENCE: Turns the auto sequence function on/off.

VALUE

Configures the detailed settings related to “CATEGORY”.

3. Press the [MENU] button to quit the menu.

Preventing Unintended Operation (Panel Lock)

Here’s how you can lock the V-8HD’s buttons and knobs to prevent unintended operation.

* The [MENU] button blinks when you try to operate a locked button, knob or other control.

1. Press the [MENU] button → “SYSTEM” → select “PANEL LOCK”, and press the [VALUE] knob.

The PANEL LOCK menu appears.

```

PANEL LOCK ( 1 / 4 )
ALL SW & VOLUME OFF
A/PGM 1 SW OFF
A/PGM 2 SW OFF
A/PGM 3 SW OFF
A/PGM 4 SW OFF
A/PGM 5 SW OFF
A/PGM 6 SW OFF
A/PGM 7 SW OFF
A/PGM 8 SW OFF
  
```

2. Use the [VALUE] knob to select a target for panel lock, and press the [VALUE] knob.

Menu item	Explanation
ALL SW & VOLUME	Turns on/off the settings of the following buttons and knobs in a single action.
A/PGM 1–8 SW	Cross-point A [1]–[8] buttons
B/PST 1–8 SW	Cross-point B [1]–[8] buttons
CUT SW	[CUT] button
AUTO SW	[AUTO] button
MODE SW	[MODE] button
AUX SW	AUX [1]–[8] buttons
PinP 1 SOURCE SW	PinP 1 [1]–[8] buttons
PinP 2 SOURCE SW	PinP 2 [1]–[8] buttons
MEMORY SW	MEMORY [1]–[8] buttons
MACRO SW	AUX / PinP SOURCE / MEMORY [1]–[8] buttons
TRANSITION SW	[TRANSITION] button
VIDEO FADER	Video fader
SPLIT/VFX A BLOCK	SPLIT/VFX [A] knob/button
SPLIT/VFX B BLOCK	SPLIT/VFX [B] knob/button
PinP 1 BLOCK	PinP 1 [POSITION H] [POSITION V] knobs, [PVW] [ON] buttons
PinP 2 BLOCK	PinP 2 [POSITION H] [POSITION V] knobs, [PVW] [ON] buttons
DSK BLOCK	DSK [LEVEL] [GAIN] knobs, [PVW] [ON] buttons
USER 1 SW	USER [1] button
USER 2 SW	USER [2] button
CAPTURE IMAGE SW	[CAPTURE IMAGE] button
OUTPUT FADE	[OUTPUT FADE] knob

3. Use the [VALUE] knob to specify whether panel lock is applied (ON) or not applied (OFF), and press the [VALUE] knob.
4. Repeat steps 2–3 as necessary.
5. Press the [MENU] button to quit the menu.

Controlling an External Recorder's Video Record Start/Stop from the V-8HD

If a recorder that supports the "HDMI REC TRIGGER" function is connected to an OUTPUT of the V-8HD, you can use the USER [1] or [2] button of the V-8HD to control video record start/stop on that recorder.

For more about recorders that support the HDMI REC TRIGGER function, refer to the Roland website.

<https://proav.roland.com/>

1. Press the [MENU] button → "SYSTEM" → select USER 1 SW or USER 2 SW "CATEGORY", and press the [VALUE] knob.

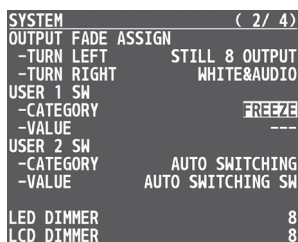

2. Use the [VALUE] knob to select "REC CONTROL", and press the [VALUE] knob.

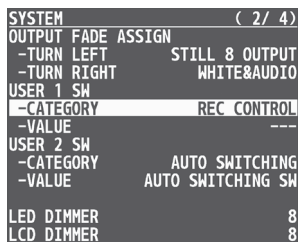

3. Press the [MENU] button to quit the menu.
4. Press the USER [1] or [2] button that is assigned to "REC CONTROL".

Each time you press the button, the recorder switches between video record start/stop.

The USER [1] or [2] button is lit red during recording, and is unlit when recording stops.

MEMO

- The lit/unlit state of the USER [1] [2] buttons indicates the state of the V-8HD, and does not reflect the state of the external recorder.
 This means that even if, while the USER [1] or [2] button is lit red, the external recorder stops recording because of an operation performed on it or because of the state of its storage, the USER [1] or [2] button does not go dark at that time.
- If you want to disable control of the recorder that supports the HDMI REC TRIGGER function, turn the VIDEO OUTPUT menu → OUTPUT 1-3 "REC CONTROL" setting "OFF".

Returning to the Factory Settings (Factory Reset)

Here's how you can return the settings of the V-8HD to their factory-set state. If following the procedures described in this manual does not cause the result you expect, try executing a factory reset.

NOTE

- When you execute factory reset, any previously specified content, any settings saved in preset memory (p. 41), and the still image (p. 29) saved in the unit will all be lost.
- Do not turn off the power while the "PLEASE WAIT" message is shown.

1. Press the [MENU] button → "SYSTEM" → select "FACTORY RESET", and press the [VALUE] knob.

A confirmation message appears.

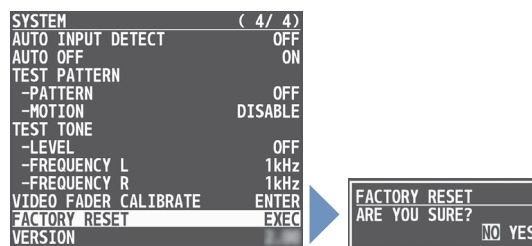

- * If you decide to cancel, press the [EXIT] button.
2. Use the [VALUE] knob to select "YES", and press the [VALUE] knob.
 The factory reset is executed.
 When the operation is finished, the message "COMPLETE" appears.
 3. Press the [MENU] button to quit the menu.

Menu List

When you press the [MENU] button, the menu is shown on this unit's monitor and on the display that's connected to the OUTPUT 3 connector.

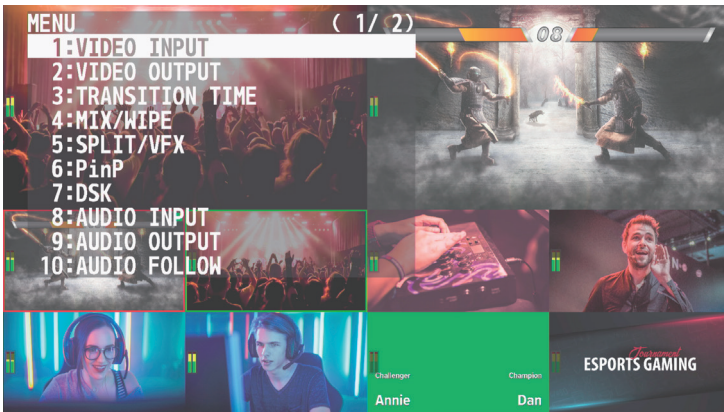

MEMO

- When a setting value has menu items that let you make more-detailed settings, "ENTER" is displayed at the top of the screen. Press the [VALUE] knob to go down a level.
- To execute an operation, press the [VALUE] knob.
- You can change a setting value rapidly by holding down the [VALUE] button and turning.
- Long pressing the [EXIT] button returns the currently selected setting to its default value.

1: VIDEO INPUT

INPUT 1–6

Menu item	Value (Bold: default)	Explanation
INPUT STATUS	ENTER	Displays information about the incoming video (format, size, etc.).
INPUT ASSIGN	HDMI , STILL 1–8	Selects the input source.
FLIP H	OFF , ON	If this is "ON", the video is input with left and right flipped.
FLIP V	OFF , ON	If this is "ON", the video is input with top and bottom flipped.
BRIGHTNESS	-32- 0 -31	Adjusts the brightness.
CONTRAST	-32- 0 -31	Adjusts the contrast.
SATURATION	-32- 0 -31	Adjusts the saturation.

INPUT 7, 8 (SCALER)

Menu item	Value (Bold: default)	Explanation
INPUT STATUS	ENTER	Displays information about the incoming video (format, size, etc.).
INPUT ASSIGN	HDMI , STILL 1–8	Selects the input source.
FLICKER FILTER	OFF , ON	If this is "ON", flickering is reduced.
FLIP H	OFF , ON	If this is "ON", the video is input with left and right flipped.
FLIP V	OFF , ON	If this is "ON", the video is input with top and bottom flipped.
EDID	INTERNAL SVGA (800x600) XGA (1024x768) WXGA (1280x800) FWXGA (1366x768) SXGA (1280x1024) SXGA+ (1400x1050) UXGA (1600x1200) WUXGA (1920x1200) 720p 1080i 1080p	Specifies the input format (EDID). If this is "INTERNAL", EDID information for all formats that can be input to the V-8HD will be transmitted. What is EDID? EDID is data that is transmitted from the V-8HD to the source device when the V-8HD is connected to a source device. EDID contains data such as the formats that can be input to the V-8HD (resolution, color space, color depth) and audio information. Based on the EDID information that the source device receives, it will output the most appropriate video format to the V-8HD.
ZOOM	10.0- 100.0 -1000.0% (*1)	Adjusts the zoom ratio.

Menu item	Value (Bold: default)	Explanation
SCALING TYPE	Specifies the scaling type.	
	FULL	Always displays the picture expanded to full screen, irrespective of the aspect ratio of the input video.
	LETTERBOX	Enlarges or reduces the incoming video to a full-screen view while keeping the aspect ratio unchanged.
	CROP	Enlarges or reduces the incoming video so that the output picture has no blank margins while keeping the aspect ratio unchanged. Video extending beyond the borders is cut off.
	DOT BY DOT	Performs no scaling.
MANUAL	Scale according to the "MANUAL SIZE H" and "MANUAL SIZE V" settings below.	
MANUAL SIZE H (*2)	-2000- 0 -2000 (*1)	Adjusts the horizontal size.
MANUAL SIZE V (*2)	-2000- 0 -2000 (*1)	Adjusts the vertical size.
POSITION H	-1920- 0 -1920	Adjusts the display position in the horizontal direction.
POSITION V	-1920- 0 -1920	Adjusts the display position in the vertical direction.
BRIGHTNESS	-32- 0 -31	Adjusts the brightness.
CONTRAST	-32- 0 -31	Adjusts the contrast.
SATURATION	-32- 0 -31	Adjusts the saturation.
RED	-64- 0 -63	Adjusts the red level.
GREEN	-64- 0 -63	Adjusts the green level.
BLUE	-64- 0 -63	Adjusts the blue level.

(*1) The valid range of setting values depends on conditions such as the input/output format.

(*2) This is valid when "SCALING TYPE" is set to "MANUAL".

2: VIDEO OUTPUT









OUTPUT 1-3

Menu item	Value (Bold: default)	Explanation
OUTPUT STATUS	—	Displays information about the output connector. When there's no connection, "NOT CONNECTED" is displayed.
OUTPUT ASSIGN	Specifies the video bus that is assigned to the OUTPUT connector.	
	PROGRAM	Outputs the program video. Default
	PREVIEW	Outputs the preview video (standby video). OUTPUT 1: PROGRAM OUTPUT 2: PREVIEW
	AUX	Outputs the AUX bus. OUTPUT 3: MULTI-VIEW
MULTI-VIEW	Outputs the multi-view monitor.	
COLOR SPACE	YPbPr 4:4:4 , RGB (0-255), RGB (16-235), YPbPr 4:2:2	Specifies the color space.
DVI-D/HDMI SIGNAL	HDMI , DVI-D	Specifies the output mode for HDMI output.
BRIGHTNESS	-64- 0 -63	Adjusts the brightness.
CONTRAST	-64- 0 -63	Adjusts the contrast.
SATURATION	-64- 0 -63	Adjusts the saturation.
RED	-64- 0 -63	Adjusts the red level.
GREEN	-64- 0 -63	Adjusts the green level.
BLUE	-64- 0 -63	Adjusts the blue level.
REC CONTROL	OFF, ON	Specifies whether video record start/stop on a recorder equipped with the HDMI REC TRIGGER function will (ON) or will not (OFF) be controlled from the V-8HD.

3: TRANSITION TIME

Menu item	Value (Bold: default)	Explanation
MIX/WIPE TIME	0.0– 1.0 –4.0sec	Specifies the video transition time.
PinP 1 TIME	0.0– 1.0 –4.0sec	Specifies the fade time with which the PinP 1 or PinP 2 inset screen appears or disappears when using Picture in Picture (PinP) compositing.
PinP 2 TIME	0.0– 1.0 –4.0sec	
DSK TIME	0.0– 1.0 –4.0sec	Specifies the fade time with which the superimposed logo or video appears or disappears when using DSK compositing.

4: MIX/WIPE

Menu item	Value (Bold: default)	Explanation			
TRANSITION TYPE	MIX , WIPE	Selects the mode of the transition effect. You can also use the [TRANSITION] button to switch between MIX and WIPE.			
MIX TYPE	Specifies the transition pattern for mix.				
	MIX	The two pictures are blended together as the video is switched.			
	FAM	Video transitions are made with the luminance levels of the two video streams maintained unchanged. This is an abbreviation of “full additive mix”.			
	NAM	The two video streams are compared, and transitions are made with display during transition starting with levels of high luminance. This is an abbreviation of “non-additive mix”.			
WIPE TYPE	Specifies the transition pattern for wipe.				
	HORIZONTAL	VERTICAL	UPPER LEFT	UPPER RIGHT	LOWER LEFT
					
	LOWER RIGHT	H-CENTER	V-CENTER		
					
WIPE DIRECTION	NORMAL, REVERSE, ROUND TRIP	Specifies the direction of wipe.			
WIPE BORDER COLOR	WHITE , YELLOW, CYAN, GREEN, MAGENTA, RED, BLUE, BLACK, SOFT EDGE	Specifies the color of the border added to the edge of the wipe area. If this is set to “SOFT EDGE”, the wipe border is blurred.			
WIPE BORDER WIDTH	0– 3 –14	Specifies the width of the border added to the edge of the wipe area.			

5: SPLIT/VFX

SPLIT/VFX A, B

Menu item	Value (Bold: default)	Explanation
SPLIT/VFX	OFF , ON	Turns the split/visual effect on/off. You can also use the SPLIT/VFX [A] or [B] button to turn this on/off.
SPLIT/VFX TYPE	SPLIT V , SPLIT H, PART MOSAIC, BACKGROUND MOSAIC, FULL MOSAIC, WAVE, RGB REPLACE, COLORPASS, NEGATIVE, COLORIZE, POSTERIZE, SILHOUETTE, EMBOSS, FIND EDGES, MONOCOLOR, HUE OFFSET, SATURATION OFFSET, VALUE OFFSET	Specifies the split/visual effect types. * The menu items differ for each split/visual effect.

■ SPLIT/VFX TYPE: SPLIT V

Composites two videos split vertically at their centers.

Menu item	Value (Bold: default)	Explanation
A-CENTER	-25.0- 0.0 -25.0%	Adjusts the horizontal position of the video shown on the left (A/PGM side). You can adjust this by turning the SPLIT/VFX [A] knob.
B-CENTER	-25.0- 0.0 -25.0%	Adjusts the horizontal position of the video shown on the right (B/PST side). You can adjust this by turning the SPLIT/VFX [B] knob.
CENTER POSITION	-50.0- 0.0 -50.0%	Adjusts the position of the boundary. You can change the size of the two videos by shifting the boundary line. You can adjust this by turning the SPLIT/VFX [A] or [B] knob while pressing it.
BORDER COLOR	WHITE , YELLOW, CYAN, GREEN, MAGENTA, RED, BLUE, BLACK	Specifies the color of the border.
BORDER WIDTH	0- 3 -14	Adjusts the width of the border.

■ SPLIT/VFX TYPE: SPLIT H

Composites two videos split horizontally at their centers.

Menu item	Value (Bold: default)	Explanation
A-CENTER	-25.0- 0.0 -25.0%	Adjusts the vertical position of the video shown above (A/PGM side). You can adjust this by turning the SPLIT/VFX [A] knob.
B-CENTER	-25.0- 0.0 -25.0%	Adjusts the vertical position of the video shown above (B/PST side). You can adjust this by turning the SPLIT/VFX [B] knob.
CENTER POSITION	-50.0- 0.0 -50.0%	Adjusts the position of the boundary. You can change the size of the two videos by shifting the boundary line. You can adjust this by turning the SPLIT/VFX [A] or [B] knob while pressing it.
BORDER COLOR	WHITE , YELLOW, CYAN, GREEN, MAGENTA, RED, BLUE, BLACK	Specifies the color of the border.
BORDER WIDTH	0- 3 -14	Adjusts the width of the border.

■ SPLIT/VFX TYPE: PART MOSAIC

Applies a mosaic to the selected region.

Menu item	Value (Bold: default)	Explanation
POSITION H	-100.0- 0.0 -100.0%	Adjusts the horizontal position of the selected area. You can adjust this by turning the SPLIT/VFX [A] or [B] knob.
POSITION V	-100.0- 0.0 -100.0%	Adjusts the vertical position of the selected area. You can adjust this by turning the SPLIT/VFX [A] or [B] knob while pressing it.
AREA SIZE	10.0- 40.0 -100.0%	Adjusts the size (zoom) of the selected area.
CORRECTION H	-2000- 0 -2000	Adjusts the horizontal size of the selected area.
CORRECTION V	-2000- 0 -2000	Adjusts the vertical size of the selected area.
BLOCK SIZE	OFF (1x1), 4x4, 8x8, 16x16, 32x32, 64x64 , 128x128, 256x256	Specifies the fineness (block size) of the mosaic.
MIX LEVEL	0- 255	Adjusts the intensity (output level) of the video with the visual effect applied.

■ SPLIT/VFX TYPE: BACKGROUND MOSAIC Applies a mosaic to the portion of the selected area.

Menu item	Value (Bold: default)	Explanation
POSITION H	-100.0- 0.0 -100.0%	Adjusts the horizontal position of the selected area. You can adjust this by turning the SPLIT/VFX [A] or [B] knob.
POSITION V	-100.0- 0.0 -100.0%	Adjusts the vertical position of the selected area. You can adjust this by turning the SPLIT/VFX [A] or [B] knob while pressing it.
AREA SIZE	10.0- 40.0 -100.0%	Adjusts the size (zoom) of the selected area.
CORRECTION H	-2000- 0 -2000	Adjusts the horizontal size of the selected area.
CORRECTION V	-2000- 0 -2000	Adjusts the vertical size of the selected area.
BLOCK SIZE	OFF (1x1), 4x4, 8x8, 16x16, 32x32, 64x64 , 128x128, 256x256	Specifies the fineness (block size) of the mosaic.
MIX LEVEL	0- 255	Adjusts the intensity (output level) of the video with the visual effect applied.

■ SPLIT/VFX TYPE: FULL MOSAIC Applies a mosaic to the entire screen.

Menu item	Value (Bold: default)	Explanation
BLOCK SIZE	OFF (1x1), 4x4, 8x8, 16x16, 32x32, 64x64 , 128x128, 256x256	Specifies the fineness (block size) of the mosaic.
MIX LEVEL	0- 255	Adjusts the intensity (output level) of the video with the visual effect applied.

■ SPLIT/VFX TYPE: WAVE Makes the video wavy.

Menu item	Value (Bold: default)	Explanation
GAIN	0- 127 -255	Adjust the height of the waves.
TYPE	1- 4 -7	Specifies the number of waves.
MIX LEVEL	0- 255	Adjusts the intensity (output level) of the video with the visual effect applied.

■ SPLIT/VFX TYPE: RGB REPLACE Exchanges the colors.

Menu item	Value (Bold: default)	Explanation
TYPE	OFF (R.G.B), B.R.G , G.B.R, R.B.G, G.R.B, B.G.R	Specifies the type of RGB replace.
MIX LEVEL	0- 255	Adjusts the intensity (output level) of the video with the visual effect applied.

■ SPLIT/VFX TYPE: COLOR PASS Turns the video black and white while preserving a specific color.

Menu item	Value (Bold: default)	Explanation
TYPE	1- 42 -63	Specifies the type of color pass.
MIX LEVEL	0- 255	Adjusts the intensity (output level) of the video with the visual effect applied.

■ SPLIT/VFX TYPE: NEGATIVE Inverts the brightness and colors.

Menu item	Value (Bold: default)	Explanation
TYPE	Pr, Pb, PbPr, Y , YPr, YPb, YPbPr	Specifies the type of negative.
MIX LEVEL	0- 255	Adjusts the intensity (output level) of the video with the visual effect applied.

■ SPLIT/VFX TYPE: COLORIZE Adds color to the video.

Menu item	Value (Bold: default)	Explanation
TYPE	1- 8	Specifies the type of colorize.
MIX LEVEL	0- 255	Adjusts the intensity (output level) of the video with the visual effect applied.

■ SPLIT/VFX TYPE: POSTERIZE Changes the gradations in brightness.

Menu item	Value (Bold: default)	Explanation
LEVEL	1- 3 -4	Specifies the gradation level for brightness.
MIX LEVEL	0- 255	Adjusts the intensity (output level) of the video with the visual effect applied.

■ SPLIT/VFX TYPE: SILHOUETTE Separates the video into light and dark areas, and makes the dark areas black and adds a different color to the light areas.

Menu item	Value (Bold: default)	Explanation
TYPE	1- 128	Specifies the hue to be colorized.
MIX LEVEL	0- 255	Adjusts the intensity (output level) of the video with the visual effect applied.

■ SPLIT/VFX TYPE: EMBOSS Adds a bas-relief effect to the video.

Menu item	Value (Bold: default)	Explanation
TYPE	1- 128	Specifies the type of emboss.
CONTRAST	0- 15	Adjusts the contrast.
MIX LEVEL	0- 255	Adjusts the intensity (output level) of the video with the visual effect applied.

■ SPLIT/VFX TYPE: FIND EDGES Extracts contours.

Menu item	Value (Bold: default)	Explanation
FG COLOR	0- 15	Specifies the color of the edge.
BG COLOR	0- 3 -15	Specifies the color of the background.
MIX LEVEL	0- 255	Adjusts the intensity (output level) of the video with the visual effect applied.

■ SPLIT/VFX TYPE: MONOCOLOR Turns the video monochrome.

Menu item	Value (Bold: default)	Explanation
Pb COLOR	0- 63	Specifies the color of the edge.
Pr COLOR	0- 63	Specifies the color of the background.
MIX LEVEL	0- 255	Adjusts the intensity (output level) of the video with the visual effect applied.

■ SPLIT/VFX TYPE: HUE OFFSET Changes the visual character by controlling the hue.

Menu item	Value (Bold: default)	Explanation
VALUE	0- 180 -359	Specifies the reference value for hue.
MIX LEVEL	0- 255	Adjusts the intensity (output level) of the video with the visual effect applied.

■ SPLIT/VFX TYPE: SATURATION OFFSET Changes the visual character by controlling the saturation.

Menu item	Value (Bold: default)	Explanation
VALUE	-256- 0 -255	Specifies the reference value for saturation.
MIX LEVEL	0- 255	Adjusts the intensity (output level) of the video with the visual effect applied.

■ SPLIT/VFX TYPE: VALUE OFFSET Changes the visual character by controlling the brightness.

Menu item	Value (Bold: default)	Explanation
VALUE	-256- 0 -255	Specifies the reference value for brightness.
MIX LEVEL	0- 255	Adjusts the intensity (output level) of the video with the visual effect applied.

6: PinP

PinP 1, 2

Menu item	Value (Bold: default)	Explanation
PinP SOURCE	HDMI 1 –8, STILL 1–8	Specifies the video source of the inset screen. If MODE is “PinP 1 SOURCE” or “PinP 2 SOURCE”, you can also use the PinP SOURCE [1]–[8] buttons to switch this.
PinP TYPE	PinP LUMINANCE-WHITE KEY LUMINANCE-BLACK KEY CHROMA KEY	Specifies the type of PinP compositing. * The menu items differ for each type.

■ PinP TYPE: PinP

Composites the video of the inset screen on top of the background video.

Menu item	Value (Bold: default)	Explanation
COPY SETTINGS FROM PinP 2 (or PinP 1)	EXEC	Copies the other PinP settings.
SWAP SETTINGS FROM PinP 2 (or PinP 1)	EXEC	Exchanges the settings of PinP 1 and PinP 2.
WINDOW	Adjusts the inset screen.	
POSITION H	-50.0– 40.0 –50.0%	Adjusts the inset screen’s display position horizontally.
POSITION V	-50.0– 40.0 –50.0%	Adjusts the inset screen’s display position vertically.
SIZE	10.0– 35.0 –100.0%	Adjusts the size (zoom) of the inset screen.
CROPPING H	0.0– 100.0%	Adjusts the horizontal size of the inset screen.
CROPPING V	0.0– 100.0%	Adjusts the vertical size of the inset screen.
SHAPE	RECTANGLE , CIRCLE, DIAMOND	Specifies the shape of the inset screen.
BORDER COLOR	WHITE , YELLOW, CYAN, GREEN, MAGENTA, RED, BLUE, BLACK, SOFT EDGE	Specifies the color of the border for the inset screen. If this is set to “SOFT EDGE”, the edge of the inset screen is blurred.
BORDER WIDTH	0– 3 –14	Adjusts the width of the border for the inset screen.
VIEW	Adjusts the video that is shown in the inset screen.	
POSITION H	-50.0– 0.0 –50.0%	Adjusts the horizontal position at which the inset screen is shown.
POSITION V	-50.0– 0.0 –50.0%	Adjusts the vertical position at which the inset screen is shown.
ZOOM	100 –400%	Adjusts the zoom of the inset screen.

■ PinP TYPE: LUMINANCE-WHITE KEY

Composites the video by applying a luminance key to the PinP to make its white areas transparent.

Menu item	Value (Bold: default)	Explanation
COPY SETTINGS FROM PinP 2 (or PinP 1)	EXEC	Copies the other PinP settings.
SWAP SETTINGS FROM PinP 2 (or PinP 1)	EXEC	Exchanges the settings of PinP 1 and PinP 2.
WINDOW	Adjusts the inset screen.	
POSITION H	-50.0– 40.0 –50.0%	Adjusts the inset screen’s display position horizontally.
POSITION V	-50.0– 40.0 –50.0%	Adjusts the inset screen’s display position vertically.
SIZE	10.0– 35.0 –100.0%	Adjusts the size (zoom) of the inset screen.
CROPPING H	0.0– 100.0%	Adjusts the horizontal size of the inset screen.
CROPPING V	0.0– 100.0%	Adjusts the vertical size of the inset screen.
VIEW	Adjusts the video that is shown in the inset screen.	
POSITION H	-50.0– 0.0 –50.0%	Adjusts the horizontal position at which the inset screen is shown.
POSITION V	-50.0– 0.0 –50.0%	Adjusts the vertical position at which the inset screen is shown.
ZOOM	100 –400%	Adjusts the zoom of the inset screen.
KEY LEVEL	0– 64 –255	Adjusts the degree of extraction (transparency) for the key.
KEY GAIN	0– 255	Adjusts the degree of edge blur (semi-transmissive region) for the key.
MIX LEVEL	0– 255	Adjusts the key’s overall density (output level).

Menu item	Value (Bold: default)	Explanation
FILL TYPE	BUS , MATTE	If this is "MATTE", the superimposed logo or video is filled-in with the specified color when using key compositing. The fill-in color is specified by "MATTE COLOR" listed below.
MATTE COLOR	WHITE, YELLOW, CYAN, GREEN, MAGENTA, RED , BLUE, BLACK	Specifies the color used when filling-in the superimposed logo or video. * This is valid when "FILL TYPE" is set to "MATTE".
EDGE TYPE	OFF , BORDER, DROP, SHADOW, OUTLINE	Specifies the type of edge applied to the superimposed logo or video.
EDGE COLOR	WHITE, YELLOW, CYAN, GREEN, MAGENTA, RED, BLUE, BLACK	Specifies the color of the edge applied to the superimposed logo or video.
EDGE WIDTH	0- 3 -14	Specifies the width of the edge applied to the superimposed logo or video.

■ PinP TYPE: LUMINANCE-BLACK KEY Composites the video by applying a luminance key to the PinP to make its black areas transparent.

Menu item	Value (Bold: default)	Explanation
COPY SETTINGS FROM PinP 2 (or PinP 1)	EXEC	Copies the other PinP settings.
SWAP SETTINGS FROM PinP 2 (or PinP 1)	EXEC	Exchanges the settings of PinP 1 and PinP 2.
WINDOW	Adjusts the inset screen.	
POSITION H	-50.0-- 40.0 -50.0%	Adjusts the inset screen's display position horizontally.
POSITION V	-50.0-- 40.0 -50.0%	Adjusts the inset screen's display position vertically.
SIZE	10.0- 35.0 -100.0%	Adjusts the size (zoom) of the inset screen.
CROPPING H	0.0- 100.0%	Adjusts the horizontal size of the inset screen.
CROPPING V	0.0- 100.0%	Adjusts the vertical size of the inset screen.
VIEW	Adjusts the video that is shown in the inset screen.	
POSITION H	-50.0- 0.0 -50.0%	Adjusts the horizontal position at which the inset screen is shown.
POSITION V	-50.0- 0.0 -50.0%	Adjusts the vertical position at which the inset screen is shown.
ZOOM	100 -400%	Adjusts the zoom of the inset screen.
KEY LEVEL	0- 64 -255	Adjusts the degree of extraction (transparency) for the key.
KEY GAIN	0- 255	Adjusts the degree of edge blur (semi-transmissive region) for the key.
MIX LEVEL	0- 255	Adjusts the key's overall density (output level).
FILL TYPE	BUS , MATTE	If this is "MATTE", the superimposed logo or video is filled-in with the specified color when using key compositing. The fill-in color is specified by "MATTE COLOR" listed below.
MATTE COLOR	WHITE, YELLOW, CYAN, GREEN, MAGENTA, RED , BLUE, BLACK	Specifies the color used when filling-in the superimposed logo or video. * This is valid when "FILL TYPE" is set to "MATTE".
EDGE TYPE	OFF , BORDER, DROP, SHADOW, OUTLINE	Specifies the type of edge applied to the superimposed logo or video.
EDGE COLOR	WHITE, YELLOW, CYAN, GREEN, MAGENTA, RED, BLUE, BLACK	Specifies the color of the edge applied to the superimposed logo or video.
EDGE WIDTH	0- 3 -14	Specifies the width of the edge applied to the superimposed logo or video.

■ PinP TYPE: CHROMA KEY

Composites the video by applying chroma key to the PinP.

Menu item	Value (Bold: default)	Explanation
COPY SETTINGS FROM PinP 2 (or PinP 1)	EXEC	Copies the other PinP settings.
SWAP SETTINGS FROM PinP 2 (or PinP 1)	EXEC	Exchanges the settings of PinP 1 and PinP 2.
WINDOW	Adjusts the inset screen.	
POSITION H	-50.0-- 40.0 -50.0%	Adjusts the inset screen's display position horizontally.
POSITION V	-50.0-- 40.0 -50.0%	Adjusts the inset screen's display position vertically.
SIZE	10.0-- 35.0 -100.0%	Adjusts the size (zoom) of the inset screen.
CROPPING H	0.0-- 100.0%	Adjusts the horizontal size of the inset screen.
CROPPING V	0.0-- 100.0%	Adjusts the vertical size of the inset screen.
VIEW	Adjusts the video that is shown in the inset screen.	
POSITION H	-50.0-- 0.0 -50.0%	Adjusts the horizontal position at which the inset screen is shown.
POSITION V	-50.0-- 0.0 -50.0%	Adjusts the vertical position at which the inset screen is shown.
ZOOM	100 -400%	Adjusts the zoom of the inset screen.
KEY LEVEL	0-- 64 -255	Adjusts the degree of extraction (transparency) for the key.
KEY GAIN	0-- 255	Adjusts the degree of edge blur (semi-transmissive region) for the key.
MIX LEVEL	0-- 255	Adjusts the key's overall density (output level).
CHROMA	Make detailed settings for chroma key.	
COLOR	GREEN, BLUE	Sets green or blue as the key color (the color to be removed). If you want a color other than green or blue to turn transparent, use "SAMPLING MARKER" to specify the key color.
HUE WIDTH	-30-- 0 -30	Adjusts the hue width for the key color.
HUE FINE	0-- 240 -360	Adjusts the center position of the hue for the key color.
SATURATION WIDTH	-30-- 0 -30	Adjusts the saturation width for the key color.
SATURATION FINE	0-- 255	Adjusts the center position of saturation for the key color.
SAMPLING MARKER	OFF , ON	If this is "ON", a sampling marker (cross-shaped cursor) is shown on the preview output video for you to sample (detect) the key color. When you execute sampling, the setting automatically turns "OFF".
POSITION H	-50-- 0 -50%	Adjusts the horizontal position of the sampling marker.
POSITION V	-50-- 0 -50%	Adjusts the vertical position of the sampling marker.
SAMPLING EXECUTE	EXEC	Executes key color sampling. The "HUE WIDTH", "HUE FINE", "SATURATION WIDTH", and "SATURATION FINE" settings are adjusted automatically.
FILL TYPE	BUS , MATTE	If this is "MATTE", the superimposed logo or video is filled-in with the specified color when using key compositing. The fill-in color is specified by "MATTE COLOR" listed below.
MATTE COLOR	WHITE, YELLOW, CYAN, GREEN, MAGENTA, RED , BLUE, BLACK	Specifies the color used when filling-in the superimposed logo or video. * This is valid when "FILL TYPE" is set to "MATTE".
EDGE TYPE	OFF , BORDER, DROP, SHADOW, OUTLINE	Specifies the type of edge applied to the superimposed logo or video.
EDGE COLOR	WHITE, YELLOW, CYAN, GREEN, MAGENTA, RED, BLUE, BLACK	Specifies the color of the edge applied to the superimposed logo or video.
EDGE WIDTH	0-- 3 -14	Specifies the width of the edge applied to the superimposed logo or video.

7: DSK

Menu item	Value (Bold: default)	Explanation
DSK MODE	Sets the DSK mode.	
	SELF KEY	Uses the luminance key (brightness) and chroma key (color) to cut out the video image and create a composite by overlaying the video on a background video.
	ALPHA KEY	Uses alpha channels (areas which contain transparency data) to cut out still images and place them against different background video as a composite.
	EXTERNAL KEY	Sets the key signal (the shape to be cut out) and the fill video (the video to be composited) separately (external key). This uses the key signal to cut out the fill video and superimpose it on the background video to create the composite.
DSK SOURCE	HDMI 1–8, STILL 1–8 * When DSK MODE = SELF KEY STILL 1–8 * When DSK MODE = ALPHA KEY	Select the source of the logo or image that you want to superimpose.
KEY SOURCE (*3)	HDMI 1–8 , STILL 1–8	Sets the video to use as the key signal (the shape to be cut out).
FILL SOURCE (*3)	HDMI 1–8 , STILL 1–8	Specifies the fill video (the video to be composited) source.
DSK TYPE (*4)	Specifies the DSK type used during DSK composition.	
	LUMINANCE-WHITE	Composite using luminance key. Makes white portions transparent according to brightness.
	LUMINANCE-BLACK	Composite using luminance key. Makes black portions transparent according to brightness.
	CHROMA	Composite using chroma key. Makes the specified key color transparent according to hue.
DSK LEVEL (*4)	0– 64 –255	Adjusts the degree of extraction (transparency) for the key.
DSK GAIN (*4)	0– 255	Adjusts the degree of edge blur (semi-transmissive region) for the key.
MIX LEVEL	0– 255	Adjusts the key's overall density (output level).
CHROMA	Make detailed settings for chroma key. * This can be set if "DSK TYPE" is "CHROMA".	
COLOR	GREEN, BLUE	Sets green or blue as the key color (the color to be removed). If you want a color other than green or blue to turn transparent, use "SAMPLING MARKER" to specify the key color.
HUE WIDTH	-30– 0 –30	Adjusts the hue width for the key color.
HUE FINE	0– 240 –360	Adjusts the center position of the hue for the key color.
SATURATION WIDTH	-30– 0 –30	Adjusts the saturation width for the key color.
SATURATION FINE	0– 255	Adjusts the center position of saturation for the key color.
SAMPLING MARKER	OFF , ON	If this is "ON", a sampling marker (cross cursor) is shown on the preview output video for you to sample (detect) the key color. When you execute sampling, the setting automatically turns "OFF".
POSITION H	-50– 0 –50%	Adjusts the horizontal position of the sampling marker.
POSITION V	-50– 0 –50%	Adjusts the vertical position of the sampling marker.
SAMPLING EXECUTE	EXEC	Executes key color sampling. The "HUE WIDTH", "HUE FINE", "SATURATION WIDTH", and "SATURATION FINE" settings are adjusted automatically.
FILL TYPE	BUS , MATTE	If this is "MATTE", the superimposed logo or video is filled-in with the specified color when using key compositing. The fill-in color is specified by "MATTE COLOR" listed below.
MATTE COLOR	WHITE, YELLOW, CYAN, GREEN, MAGENTA, RED , BLUE, BLACK	Specifies the color used when filling-in the superimposed logo or video. * This is valid when "FILL TYPE" is set to "MATTE".
EDGE TYPE	OFF , BORDER, DROP, SHADOW, OUTLINE	Specifies the type of edge applied to the superimposed logo or video.
EDGE COLOR	WHITE, YELLOW, CYAN, GREEN, MAGENTA, RED, BLUE, BLACK	Specifies the color of the edge applied to the superimposed logo or video.
EDGE WIDTH	0– 3 –14	Specifies the width of the edge applied to the superimposed logo or video.

(*3) This can be set if "DSK MODE" is "EXTERNAL KEY".

(*4) This can be set if "DSK MODE" is "SELF KEY".

8: AUDIO INPUT

HDMI IN 1–8, AUDIO INPUT

Menu item	Value (Bold: default)	Explanation
INPUT LEVEL	-INF- 0.0 -10.0dB	Adjusts the input volume.
INPUT MUTE	OFF , ON	Turns the mute function on/off. If this is "ON", the input audio is temporarily silenced.
MONO	Converts the input audio from stereo to mono.	
	OFF	Sends the stereo input audio without change.
	L ONLY	The audio of the L channel is sent to both L and R.
	R ONLY	The audio of the R channel is sent to both L and R.
	LR MIX	The audio of the L channel and R channel is mixed, and sent to both L and R.
SOLO	OFF , ON	Turns the solo function on/off. Only the audio for which this is "ON" is heard in the headphones. * The solo function applies to the headphone output. It does not affect output other than the headphones.
EFFECT PRESET	Specifies an effect preset (high-pass filter, compressor, equalizer). * When you change a preset, the settings of each effect are overwritten.	
	DEFAULT	For line input (default setting)
	MEETING	For meetings
	INTERVIEW	For interviews
	AMBIENT MIC	For capturing ambient sound
	WINDY FIELD	For capturing ambient sound in a windy area
	DE-ESS & POPS SOFT	For reducing sibilants
	DE-ESS & POPS HARD	For reducing plosives
DELAY	0.0 -500.0msec (0.0 -29.9/25.0frame)	Adjusts the delay time of the audio. Effect This outputs audio with a delay.
HIGH PASS FILTER 75Hz	OFF , ON	Turns the high-pass filter on/off. Effect Cuts off unneeded low-band audio. The cutoff frequency is 75 Hz.
NOISE GATE	OFF , ON	Turns the noise gate on/off. Effect This mutes audio that is below a specified level.
THRESHOLD	-80.0-- 50.0 -0.0dB	Specifies the level used as the threshold for removing audio. Audio below the level set here is removed.
RELEASE	30- 380 -5000ms	Adjusts the length of time until the audio is fully attenuated after audio falls below the threshold.
COMPRESSOR	OFF , ON	Turns the compressor on/off. Effect This compresses audio that exceeds a specified level.
THRESHOLD	-80.0-- 50.0 -0.0dB	Specifies the level used as the threshold at which the compressor is applied. Compression is applied to audio that exceeds the threshold.
RATIO	1.00: 1, 1.12: 1, 1.25: 1, 1.40: 1, 1.60: 1, 1.80: 1, 2.00: 1, 2.50: 1, 3.20: 1, 4.00: 1, 5.60: 1 , 8.00: 1, 16.0: 1, INF: 1	Specifies the degree of compression applied to the audio. The state in which no compression is applied is defined as "1".
ATTACK	0.2- 1 -100ms	Specifies the time until compression starts when audio exceeding the threshold is input.
RELEASE	30- 380 -5000ms	Adjusts the length of time until compression ends after audio falls below the threshold.
AUTO GAIN	OFF, ON	Turns the auto makeup gain feature on/off. If this is "ON", the final output volume level after applying the compressor is automatically adjusted according to the "THRESHOLD" and "RATIO" settings. The total of the "MAKEUP GAIN" setting value described below and the value calculated by auto makeup gain becomes the final output volume level (up to +34 dB).
MAKEUP GAIN	-40- 0 -40dB	Adjusts the final output volume after applying the compressor.
EQUALIZER	OFF , ON	Turns the equalizer on/off. Effect Adjusts the tone for each frequency band.
Hi GAIN	-15.0- 0.0 -15.0dB	Boosts or attenuates the high band.
Hi FREQUENCY	1.0- 10.0 -20.0kHz	Specifies the center frequency when changing the tone in the high band.
Mid GAIN	-15.0- 0.0 -15.0dB	Boosts or attenuates the middle band.

Menu item	Value (Bold: default)	Explanation
Mid FREQUENCY	20.0– 500Hz –20.0kHz	Specifies the center frequency when changing the tone in the middle band.
Mid Q	0.5– 1.0 –16.0	Adjusts the width of the frequency band when boosting or attenuating the middle band.
Lo GAIN	-15.0– 0.0 –15.0dB	Boosts or attenuates the low band.
Lo FREQUENCY	20.0– 500Hz –20.0kHz	Specifies the center frequency when changing the tone in the low band.

9: AUDIO OUTPUT

OUTPUT ASSIGN

Menu item	Value (Bold: default)	Explanation						
AUDIO OUT	MASTER OUTPUT , AUX	Specifies the audio bus that is assigned to each connector. MASTER OUTPUT: All input audio is mixed and output (master output).						
PHONES OUT	MASTER OUTPUT , AUX	AUX: Only the input audio sent to the AUX bus is mixed and output. This allows you to output audio that is different than the master output.						
HDMI OUTPUT 1–3	AUTO , MASTER OUTPUT, AUX	AUTO: The audio bus automatically switches according to the video bus assignment. <table border="1" style="margin-left: 20px;"> <thead> <tr> <th>Video bus</th> <th>Audio bus</th> </tr> </thead> <tbody> <tr> <td>Others besides AUX</td> <td>MASTER OUTPUT</td> </tr> <tr> <td>AUX</td> <td>AUX</td> </tr> </tbody> </table>	Video bus	Audio bus	Others besides AUX	MASTER OUTPUT	AUX	AUX
Video bus	Audio bus							
Others besides AUX	MASTER OUTPUT							
AUX	AUX							

MASTER OUTPUT

Menu item	Value (Bold: default)	Explanation
OUTPUT LEVEL	-INF– 0.0 –10.0dB	Adjusts the output volume.
OUTPUT MUTE	OFF , ON	Turns the mute function on/off. If this is “ON”, the output audio is temporarily silenced.
LIMITER	OFF , ON	Turns the limiter on or off. Effect This limits the output volume so that it does not exceed the set level.
THRESHOLD	-40.0– 6.0 –0.0db	Adjusts the level that becomes the threshold at which the limiter is applied. Compression is applied to audio that exceeds the threshold. The volume level of audio that is output is limited so as to stay to below the threshold.
EQUALIZER	OFF , ON	Turns the equalizer on/off. Effect Adjusts the tone for each frequency band.
Hi GAIN	-15.0– 0.0 –15.0dB	Boosts or attenuates the high band.
Hi FREQUENCY	1.0– 10.0 –20.0kHz	Specifies the center frequency when changing the tone in the high band.
Mid GAIN	-15.0– 0.0 –15.0dB	Boosts or attenuates the middle band.
Mid FREQUENCY	20.0– 500Hz –20.0kHz	Specifies the center frequency when changing the tone in the middle band.
Mid Q	0.5– 1.0 –16.0	Adjusts the width of the frequency band when boosting or attenuating the middle band.
Lo GAIN	-15.0– 0.0 –15.0dB	Boosts or attenuates the low band.
Lo FREQUENCY	20.0– 500Hz –20.0kHz	Specifies the center frequency when changing the tone in the low band.
MULTI BAND COMPRESSOR	OFF , ON	Turns the multi-band compressor on/off. Effect Applies separate compressors in individual frequency band.
Hi THRESHOLD	-40.0– 20.0 –0.0dB	Specifies the threshold level at which the compressor is applied to the high band. Compression is applied to audio that exceeds the threshold.
Hi RATIO	1.00: 1, 1.12: 1, 1.25: 1, 1.40: 1, 1.60: 1, 1.80: 1, 2.00: 1, 2.50: 1, 3.20: 1 , 4.00: 1, 5.60: 1, 8.00: 1, 16.0: 1, INF: 1	Specifies the amount of compression applied in the high band. The state in which no compression is applied is defined as “1”.
Mid THRESHOLD	-40.0– 16.0 –0.0dB	Specifies the threshold level at which the compressor is applied to the middle band. Compression is applied to audio that exceeds the threshold.

Menu item	Value (Bold: default)	Explanation
Mid RATIO	1.00: 1, 1.12: 1, 1.25: 1, 1.40: 1, 1.60: 1, 1.80: 1, 2.00: 1, 2.50: 1 , 3.20: 1, 4.00: 1, 5.60: 1, 8.00: 1, 16.0: 1, INF: 1	Specifies the amount of compression applied in the middle band. The state in which no compression is applied is defined as "1".
Lo THRESHOLD	-40.0-- 20.0 --0.0dB	Specifies the threshold level at which the compressor is applied to the low band. Compression is applied to audio that exceeds the threshold.
Lo RATIO	1.00: 1, 1.12: 1, 1.25: 1, 1.40: 1, 1.60: 1, 1.80: 1, 2.00: 1, 2.50: 1, 3.20: 1 , 4.00: 1, 5.60: 1, 8.00: 1, 16.0: 1, INF: 1	Specifies the amount of compression applied in the low band. The state in which no compression is applied is defined as "1".

AUX

Menu item	Value (Bold: default)	Explanation
AUX LEVEL	-INF- 0.0 --10.0dB	Adjusts the output volume of the AUX bus.
AUX MUTE	OFF , ON	Turns the mute function on/off. If this is "ON", the output audio of the AUX bus is temporarily silenced.
DELAY	0.0 --500.0msec (0.0 --29.9/25.0frame)	Adjusts the delay time for output audio.
LIMITER	OFF , ON	Turn the limiter on/off. Effect This limits the output volume so that it does not exceed the set level.
THRESHOLD	-40.0-- 6.0 --0.0db	Adjusts the level that becomes the threshold at which the limiter is applied. Compression is applied to audio that exceeds the threshold. The volume level of audio that is output is limited so as to stay to below the threshold.
AUX SEND	ENTER	Displays the following AUX SEND menu.
	Menu item	Value (Bold: default)
	AUX SEND VIDEO	<p>Selects how to configure the amount of signal sent to the AUX bus for INPUT 1–8.</p> <p>AUTO Audio is automatically sent to the AUX bus in tandem with the AUX bus video selection.</p> <p>MANUAL The amount of audio to send is adjusted manually.</p>
	HDMI IN 1–8	-INF -0dB Adjusts the amount of audio sent to the AUX bus for each input.
	AUDIO IN	-INF -0dB * You can configure HDMI 1–8 when AUX SEND VIDEO is set to "MANUAL".
AUX EFFECT	ENTER	Displays the following AUX EFFECT menu.
	Menu item	Value (Bold: default)
	HDMI IN 1–8	<p>Sets whether to send audio from each input to the AUX bus with effects applied or not.</p> <p>DRY Sends the source audio with no effects applied.</p> <p>PRE FADER Sends the effect-applied audio. The send volume is constant, regardless of the volume (INPUT LEVEL).</p>
	AUDIO IN	<p>POST FADER Sends the effect-applied audio. The send volume can be changed by adjusting the volume (INPUT LEVEL).</p>

10: AUDIO FOLLOW

Menu item	Value (Bold: default)	Explanation
ALL AUDIO FOLLOW	OFF , ON	Turns on/off the audio follow function for INPUT 1–8 in a single action.
INPUT 1–8	<p>Turns the audio follow function on/off. Audio follow is a function that automatically switches the audio output in tandem with video switching.</p> <p>OFF</p>	The audio is always output regardless of the video selection.
	ON	The audio is output only when the video is selected. The audio is automatically muted if another video is selected.
AUDIO IN	OFF , INPUT 1–8	Specifies the input video (INPUT 1–8) that uses audio follow for the audio of AUDIO IN. The audio of AUDIO IN is output only when the specified input video is selected. If this is "OFF", the audio of AUDIO IN is always output regardless of the input video selection.

11: PRESET MEMORY

Menu item	Value (Bold: default)	Explanation
LOAD	1: MEMORY1 –24: MEMORY24 (*5)	Selects the preset memory to load. Pressing the [VALUE] knob lets you load the preset memory.
SAVE	1: MEMORY1 –24: MEMORY24 (*5)	Selects a preset memory for saving settings. Pressing the [VALUE] knob lets you save the settings to the preset memory. * The state of the [OUTPUT FADE] knob and [PHONES] knob (headphone volume) is not saved in preset memory. * The following settings menu are common to the unit (one set for the entire unit), and therefore are not saved in preset memory. <ul style="list-style-type: none"> • PRESET MEMORY • MACRO • SEQUENCER • STILL IMAGE • FREEZE • AUTO SWITCHING • CTL/EXP • USB MEMORY • SYSTEM
INITIALIZE	1: MEMORY1 –24: MEMORY24 (*5)	Selects the preset memory to be initialized. Press the [VALUE] knob to initialize the preset memory.
NAME EDIT	1: MEMORY1 –24: MEMORY24 (*5)	Selects the preset memory to be renamed. Press the [VALUE] knob to edit the name.
START UP	Specifies the settings loaded at startup.	
	LAST MEMORY	Restores the state that was in effect immediately before the power was turned off (Last Memory function). The current settings (Last Memory values) are saved every 4 seconds, and when you exit a menu.
	1: MEMORY1 –24: MEMORY24 (*5)	Recall the settings at the selected memory number.
MEMORY PROTECT	OFF , ON	When this is "ON", prohibits settings from being saved or initialized. This protects the preset memories.
LOAD FROM USB MEMORY	ENTER	Shows a list of the preset files (.V08preset) that are on the USB flash drive. You can select a preset file and load the preset memory (1–24) into the unit.
SAVE TO USB MEMORY	ENTER	Shows a list of the preset files (.V08preset) that are on the USB flash drive. You can select the preset file used to overwrite the preset memory (1–24). If you selected "NEW FILE...", a new preset file is saved.
NUMBER OF MEMORY SW	When MEMORY is selected on the [MODE] button, this sets how many buttons function as memory selection buttons.	
	8	Preset memory 1–8: MEMORY [1]–[8] buttons
	24	Preset memory 1–8: MEMORY [1]–[8] buttons Preset memory 9–16: Cross-point A [1]–[8] buttons Preset memory 17–24: Cross-point B [1]–[8] buttons
FADE TIME	0.0 –4.0sec	Specifies the time of the transition when loading a preset memory.
MIX/WIPE	OFF, ON	Switches the transition effect on/off.
PinP 1	OFF, ON	
PinP 2	OFF, ON	
DSK	OFF, ON	
LOAD PARAMETER	Specifies the menu items that are applied when a preset memory is recalled.	
VIDEO INPUT	OFF, ON	Menu items for which this is "OFF" do not change when a preset memory is recalled.
VIDEO OUTPUT	OFF, ON	
TRANSITION TIME	OFF, ON	
MIX/WIPE	OFF, ON	
SPLIT/VFX	OFF, ON	
PinP	OFF, ON	
DSK	OFF, ON	
VIDEO CROSSPOINT	OFF, ON	
VIDEO FADER	INITIALIZE , ON	Switches whether to load the video fader position in a reset state (INITIALIZE) or to reproduce its state when the preset memory was saved (ON).
AUDIO INPUT	OFF, ON	Menu items for which this is "OFF" do not change when a preset memory is recalled.
AUDIO OUTPUT	OFF, ON	
AUDIO FOLLOW	OFF, ON	

(*5) If you edited a preset memory's name using "NAME EDIT", the edited name is shown.

12: MACRO

Menu item	Value (Bold: default)	Explanation	
EXECUTE	1: DEMO 1 – 100: MACRO100 (*6)	Select a macro (a series of recorded operations) to execute. Press the [VALUE] knob to execute the macro. If MODE is macro (the [MODE] button is lit orange), you can use the AUX / PinP SOURCE / MEMORY [1]–[8] buttons to execute macros 1–8.	
INITIALIZE	ALL, 1: DEMO 1 – 100: MACRO100 (*6)	Selects the macro to be initialized. Press the [VALUE] knob to initialize the macro.	
LIST EDIT	1: DEMO 1 – 100: MACRO100 (*6)	Selects the macro to edit. Press the [VALUE] knob to show the operations recorded in the macro.	
	Menu item	Value	Explanation
	1: (operation name) – 10: (operation name)	—	Shows the list of operations recorded in the macro. "-----" is shown if no operations are recorded. Select an operation or "ADD NEW FUNCTION" and press the [VALUE] knob to display the FUNCTION EDIT menu (p. 80) for editing the operation.
	PREVIEW	EXEC	Previews the macro.
	COPY MACRO TO	1: DEMO 1– 100: MACRO100 (*6)	Specifies the macro copy source. Press the [VALUE] knob to copy the macro.
	SWAP MACRO WITH	1: DEMO 1– 100: MACRO100 (*6)	Specifies the macro swap destination. Press the [VALUE] knob to swap the macro.
NAME EDIT	1: DEMO 1 – 100: MACRO100 (*6)	Selects the macro to be renamed. Press the [VALUE] knob to access the screen for editing the name.	
LOAD FROM USB MEMORY	ENTER	Shows a list of the macro setting files (.RMF) that are on the USB flash drive. You can select a macro setting file and load the macro (1–100) into the unit.	
SAVE TO USB MEMORY	ENTER	Shows a list of the macro setting files (.RMF) that are on the USB flash drive. You can select the macro settings file used to overwrite the macro (1–100) to the USB flash drive. If you selected "NEW FILE...", a new macro settings file is saved.	
NUMBER OF MACRO SW	When "MACRO" is selected on the [MODE] button, this sets how many buttons function as macro selection buttons.		
	8	Macro 1–8: AUX / PinP SOURCE / MEMORY [1]–[8] buttons	
	24	Macro 1–8: AUX / PinP SOURCE / MEMORY [1]–[8] buttons Macro 9–16: Cross-point A [1]–[8] buttons, Macro 17–24: Cross-point B [1]–[8] buttons	
SW ASSIGN	ENTER	Displays the following SW ASSIGN menu.	
	Specifies the macro assigned to each button.		
	Menu item	Value	Explanation
	MACRO 1–8	1: DEMO 1– 100: MACRO100 (*6)	AUX / PinP SOURCE / MEMORY [1]–[8] buttons
	PGM/A 1–8 (*7)		Cross-point A [1]–[8] buttons
PST/B 1–8 (*7)	Cross-point B [1]–[8] buttons		

(*6) If you edited a macro's name using "NAME EDIT", the edited name is shown.

(*7) This can be set if "NUMBER OF MACRO SW" is "24".

FUNCTION EDIT

Menu item	Value (Bold: default)	Explanation
FUNCTION	PGM TAKE	SPLIT/VFX TYPE
	PGM/PST SELECT	SPLIT POSITION
	AUX SELECT	AUDIO INPUT LEVEL
	INPUT ASSIGN	AUDIO INPUT MUTE
	TRANSITION TIME	AUDIO OUTPUT LEVEL
	TRANSITION TYPE	AUDIO OUTPUT MUTE
	PinP ON/OFF	PRESET MEMORY
	PinP SOURCE	MACRO
	PinP WINDOW	OUTPUT FADE
	DSK ON/OFF	REC CONTROL
	DSK SOURCE	WAIT
	SPLIT/VFX ON/OFF	
TIMING	Sets the timing of the operation to execute.	
	AFTER PREVIOUS	The function is executed after the preceding one. The next sequential list number is used.
	SAME AS PREVIOUS	Executes the operation at the same time as the preceding one. The same list number as the previous operation is used.
MOVE THIS FUNCTION	ENTER	Moves the operation being edited and resorts the list.
COPY THIS FUNCTION	ENTER	Copies the operation being edited into a position in the list you desire.
DELETE THIS FUNCTION	EXEC	Deletes the operation being edited.

13: SEQUENCER

Menu item	Value (Bold: default)	Explanation																																											
SEQUENCER	OFF , ON	Turns the sequencer function on/off.																																											
REPEAT EXECUTE	OFF , ON	When this is "ON", the recorded operation is repeatedly executed.																																											
AUTO SEQUENCE	OFF , ON	Turns the auto sequence function on/off. * This is valid when "SEQUENCER " is set to "ON".																																											
LIST EDIT	ENTER	Shows a list of operations recorded in the sequencer. Select an operation or "ADD NEW FUNCTION" and press the [VALUE] knob to show the following FUNCTION EDIT menu, where you can edit the operation.																																											
	<table border="1"> <thead> <tr> <th>Menu item</th> <th>Value</th> <th>Explanation</th> </tr> </thead> <tbody> <tr> <td rowspan="3">FUNCTION</td> <td colspan="2">Sets the operation to record to the sequencer. The related menu is shown according to the operation you set.</td> </tr> <tr> <td>PGM TAKE</td> <td>Switches the final output video.</td> </tr> <tr> <td>PRESET MEMORY</td> <td>Recalls a preset memory.</td> </tr> <tr> <td></td> <td>MACRO</td> <td>Executes a macro (a series of recorded operations).</td> </tr> <tr> <td>NAME</td> <td>—</td> <td>Shows the name of the operation.</td> </tr> <tr> <td rowspan="2">EDIT</td> <td colspan="2">Sets how naming is done.</td> </tr> <tr> <td>AUTO</td> <td>Names are automatically given.</td> </tr> <tr> <td></td> <td>CUSTOM</td> <td>Names can be assigned as you like. Press the [VALUE] knob to access the screen for editing the name.</td> </tr> <tr> <td rowspan="3">AUTO SEQUENCE</td> <td colspan="2">Sets the operation when auto sequence is on.</td> </tr> <tr> <td>PAUSE</td> <td>Pauses the auto sequence.</td> </tr> <tr> <td>AUTO</td> <td>Executes the next operation in the sequence.</td> </tr> <tr> <td></td> <td>1-5-120sec</td> <td>Executes the next operation after delaying for a specified amount of time.</td> </tr> <tr> <td>MOVE THIS FUNCTION</td> <td>ENTER</td> <td>Moves the operation being edited and resorts the list.</td> </tr> <tr> <td>COPY THIS FUNCTION</td> <td>ENTER</td> <td>Copies the operation being edited into a position in the list you desire.</td> </tr> <tr> <td>DELETE THIS FUNCTION</td> <td>ENTER</td> <td>Deletes the operation being edited.</td> </tr> </tbody> </table>		Menu item	Value	Explanation	FUNCTION	Sets the operation to record to the sequencer. The related menu is shown according to the operation you set.		PGM TAKE	Switches the final output video.	PRESET MEMORY	Recalls a preset memory.		MACRO	Executes a macro (a series of recorded operations).	NAME	—	Shows the name of the operation.	EDIT	Sets how naming is done.		AUTO	Names are automatically given.		CUSTOM	Names can be assigned as you like. Press the [VALUE] knob to access the screen for editing the name.	AUTO SEQUENCE	Sets the operation when auto sequence is on.		PAUSE	Pauses the auto sequence.	AUTO	Executes the next operation in the sequence.		1-5-120sec	Executes the next operation after delaying for a specified amount of time.	MOVE THIS FUNCTION	ENTER	Moves the operation being edited and resorts the list.	COPY THIS FUNCTION	ENTER	Copies the operation being edited into a position in the list you desire.	DELETE THIS FUNCTION	ENTER	Deletes the operation being edited.
	Menu item	Value	Explanation																																										
	FUNCTION	Sets the operation to record to the sequencer. The related menu is shown according to the operation you set.																																											
		PGM TAKE	Switches the final output video.																																										
		PRESET MEMORY	Recalls a preset memory.																																										
		MACRO	Executes a macro (a series of recorded operations).																																										
	NAME	—	Shows the name of the operation.																																										
	EDIT	Sets how naming is done.																																											
		AUTO	Names are automatically given.																																										
		CUSTOM	Names can be assigned as you like. Press the [VALUE] knob to access the screen for editing the name.																																										
	AUTO SEQUENCE	Sets the operation when auto sequence is on.																																											
		PAUSE	Pauses the auto sequence.																																										
		AUTO	Executes the next operation in the sequence.																																										
	1-5-120sec	Executes the next operation after delaying for a specified amount of time.																																											
MOVE THIS FUNCTION	ENTER	Moves the operation being edited and resorts the list.																																											
COPY THIS FUNCTION	ENTER	Copies the operation being edited into a position in the list you desire.																																											
DELETE THIS FUNCTION	ENTER	Deletes the operation being edited.																																											
INITIALIZE	EXEC	Initializes the sequencer.																																											
LOAD FROM USB MEMORY	ENTER	Shows a list of the sequence files (.SEQ) that are on the USB flash drive. You can select a sequence file to load the sequencer settings into this unit. The current sequencer settings are overwritten.																																											
SAVE TO USB MEMORY	ENTER	Shows a list of the sequence files (.SEQ) that are on the USB flash drive. You can select a sequence file to overwrite the current sequencer settings. If you selected "NEW FILE..."; a new sequence file is saved.																																											

14: STILL IMAGE

Menu item	Value (Bold: default)	Explanation
LOAD FROM USB MEMORY	STILL 1–8	Loads a still image from a USB flash drive and saves it in this unit. Specifies the save-destination for the still image that is loaded from the USB flash drive. If a still image is already saved, an “*” is shown. When you press the [VALUE] knob, a list of the still images on the USB flash drive is shown. Select the still image that you want to load, and press the [VALUE] knob to save the still image in this unit.
SAVE TO USB MEMORY	STILL 1–8	Saves a still image captured from the input video to a USB flash drive. Select the still image memory (“STILL 1”–“STILL 8”) that you want to save. Memories in which a still image is saved are indicated by a “*” symbol. Select the FILE TYPE (file format), and enter a file name. Select “SAVE”, and then press the [VALUE] knob to save the still image to the USB flash drive. * An image captured while HDCP is ON cannot be saved.
SAVE TO INTERNAL STORAGE	Use this to set whether to save still images you’ve captured or loaded to this unit’s internal memory.	
	DISABLE	Temporarily saves still images to internal memory. This lets you capture images while the audio is still playing. * When you turn off the power, the still image is deleted.
	ENABLE	Saves still images to internal memory. * All audio stops during still-image capture.
DELETE STILL IMAGE	ALL, STILL 1–8	Selects the still images to delete. Press the [VALUE] knob to delete the still images.

15: FREEZE

Menu item	Value (Bold: default)	Explanation
FREEZE	OFF , ON	Turns the freeze function on/off. If this is “ON”, the input video is temporarily frozen. If “FREEZE” is assigned to the USER [1] or [2] button, you can also switch this by pressing the button.
TYPE	Specifies the type of freeze function.	
	ALL	Freezes all video that is being input.
	SELECT	Freezes only the specified input video.
HDMI IN 1–8	ENABLE , DISABLE	For each input, specifies whether the freeze function is enabled (ENABLE) or disabled (DISABLE). * This is shown if TYPE is “SELECT”.

16: AUTO SWITCHING

Menu item	Value (Bold: default)	Explanation
AUTO SWITCHING	OFF , ON	Turns the auto switching function on/off. If this is "ON", the INPUT 1–8 video or preset memory are switched automatically. If "AUTO SWITCHING" is assigned to the USER [1] or [2] button, you can also switch this by pressing the button.
TYPE	INPUT SCAN PRESET MEMORY SCAN BPM SYNC	Specifies the type of auto switching function. * The menu items differ for each type.

■ TYPE: INPUT SCAN Automatically switches to the video of INPUT 1–8 when the specified time elapses.

Menu item	Value (Bold: default)	Explanation
SCAN SEQUENCE	Specifies the order in which video signals are shown. Channels that have no video input are skipped.	
	NORMAL	Switches in the order of INPUT 1 → 8.
	REVERSE	Switches in the order of INPUT 8 → 1.
	RANDOM	Switches randomly.
SCAN TRANSITION TIME	0.0– 1.0 –4.0sec	Specifies the video transition time.
SCAN TARGET	Specifies the video bus in which video transition.	
	A/B PinP 1, PinP 2	Switches between A/PGM bus and B/PST bus. Switches the video you want to make the inset screen of the PinP 1 or PinP 2.
INPUT 1–8 TIME	OFF, 1– 5 –120sec	Specifies the time that the video is shown. If this is "OFF", video switching does not affect the input.

■ TYPE: PRESET MEMORY SCAN This automatically switches between preset memories 1–8. The video and audio are switched according to the settings that are saved in each preset memory.

Menu item	Value (Bold: default)	Explanation
SCAN SEQUENCE	Specifies the order in which preset memories are switched. * Preset memories in which no settings have been saved are skipped.	
	NORMAL	Switches in the order of preset memory 1 → 24.
	REVERSE	Switches in the order of preset memory 24 → 1.
	RANDOM	Switches randomly.
MEMORY 1–24 TIME	OFF, 1– 5 –120sec	Specifies the time that the video is shown. If this is "OFF", video switching does not affect the input.

■ TYPE: BPM SYNC This automatically switches the video at specified BPM intervals.

Menu item	Value (Bold: default)	Explanation
BPM	20– 120 –250	Specifies the BPM.
MODE	Specifies how the picture is switched.	
	TRANSITION	The picture switches using the currently selected transition effect (mix or wipe).
	CUT	The picture switches instantly.
SPEED	x1/4, x1/2, x1 , x2	Specifies the picture switching speed as a multiple of the specified BPM.

17: CTL/EXP

CTL/EXP 1, 2

Menu item	Value (Bold: default)	Explanation	
CTL/EXP TYPE	Specifies the device (footswitch, expression pedal) that is connected to the CTL/EXP jack.		
	OFF	Disables the CTL/EXP jack.	
	CTL A & CTL B	Choose this if a footswitch is connected.	
	EXP	Choose this if an expression pedal is connected.	
ASSIGN	Specifies the functions that are assigned to CTL A and CTL B of the footswitch. * This is valid when "CTL/EXP TYPE" is set to "CTL A & CTL B".		
CTL A CTL B	CATEGORY	VALUE	Explanation
	N/A	---	No function is assigned.
	A/PGM CH SELECT	INPUT 1-8	Switches the video sent to the A/PGM bus.
	B/PST CH SELECT	INPUT 1-8	Switches the video sent to the B/PST bus.
	AUX CH SELECT	INPUT 1-8	Switches the video sent to the AUX bus.
	INPUT ASSIGN	INPUT 1-8	Each time you press the footswitch, the video source of the specified input channel switches.
	STILL OUTPUT	STILL 1-8	Pauses the normal output, and preview/final outputs a cut of the still image.
	PinP 1, 2 SOURCE	HDMI 1-8, STILL 1-8	Switches the video shown in the PinP 1 or PinP 2 inset screen.
	DSK SOURCE	HDMI 1-8, STILL 1-8	Switches the DSK video source.
	SW CONTROL	CUT SW, AUTO SW TRANSITION SW MODE SW SPLIT/VFX A, B SW PinP 1, 2 PVW SW PinP 1, 2 ON SW DSK PVW SW DSK ON SW USER 1, 2 SW	This works the same as when you press the button selected in "VALUE".
	TAKE	▲ AUTO TAKE ▼	Automatically switches the A/ PGM/ bus and B/PST bus videos.
		▲ CUT ▼	Switches the video between PGM/A bus and PST/B bus as a cut.
	AUDIO INPUT MUTE	HDMI IN 1-8, AUDIO IN	Turns the mute function on/off for the input audio.
	AUDIO OUTPUT MUTE	MASTER OUTPUT, AUX	Turns the mute function on/off for the output audio.
	AUDIO INPUT SOLO	HDMI IN 1-8, AUDIO IN	Turns the solo function on/off for the input audio.
	OUTPUT FADE	LEFT, RIGHT	The same function as turning the [OUTPUT FADE] knob to the left or right.
	LOAD MEMORY	MEMORY 1-24	Recalls a preset memory.
	INPUT SCAN	NORMAL	Each time you press the footswitch, the final output switches from INPUT 1-8 in sequential order.
		REVERSE	Each time you press the footswitch, the final output switches from INPUT 1-8 in reverse order.
	MEMORY SCAN	NORMAL	Each time you press the footswitch, preset memories 1-24 are recalled in sequential order.
		REVERSE	Each time you press the footswitch, preset memories are recalled in reverse order from 24 through 1.
	MACRO EXECUTE	MACRO 1-100	Executes a macro (a series of recorded operations).
	SEQUENCER	MODE ON/OFF	Turns sequencer function on/off.
		NEXT	When the sequencer function is on, the same operation as when you press the [AUTO] button.
		PREVIOUS	When the sequencer function is on, the same operation as when you press the [CUT] button.
		AUTO SEQUENCE	Turns the auto sequence function on/off.

Menu item	Value (Bold: default)	Explanation
EXP	Specifies the function that is assigned to the expression pedal. * This is valid when "CTL/EXP TYPE" is set to "EXP".	
	CATEGORY	VALUE
	N/A	---
	VIDEO FADER	FADE
		▲ CUT ▼
	VFX MIX LEVEL	VFX A, VFX B
	OUTPUT FADE	LEFT, RIGHT
	STILL OUTPUT	STILL 1–8
	AUDIO INPUT LEVEL	HDMI IN 1–8, AUDIO IN
AUDIO OUTPUT LEVEL	MASTER OUTPUT, AUX	
EXP CALIBRATE	ENTER	<p>Displays the EXP CALIBRATE screen.</p> <p>Following the direction on the screen, calibrate (adjust) the expression pedal.</p> <p>The first time you use the expression pedal, be sure to execute calibration so that the pedal will operate optimally.</p> <p>In some cases, the expression pedal might no longer be operating optimally because of the passage of time or the conditions of use. In such cases you should also execute expression pedal calibration.</p> <p>* This is valid when "CTL/EXP TYPE" is set to "EXP".</p>

18: USB MEMORY

Menu item	Value (Bold: default)	Explanation
RESTORE ALL SETTINGS	ENTER	<p>This loads settings that are in a preset memory saved on a USB flash drive.</p> <p>When you press the [VALUE] knob, a list of the files in the USB flash drive appears.</p> <p>When you select the file that you want to recall and press the [VALUE] knob, the contents of this unit are overwritten.</p>
BACKUP ALL SETTINGS	ENTER	<p>Saves the current settings as a file on the USB flash drive.</p> <p>When you press the [VALUE] knob, a list of the files in the USB flash drive appears.</p> <p>If you are saving as a new file, select "NEW FILE..." and enter a file name.</p> <p>If you are overwriting an existing file, select that file in the list.</p> <p>When you press the [VALUE] knob, the file is saved to the USB flash drive.</p>
FORMAT	EXEC	<p>Formats the USB flash drive.</p> <p>When you press the [VALUE] knob, format is executed.</p>

19: SYSTEM

Menu item	Value (Bold: default)	Explanation	
HDCP	OFF , ON	Specifies whether HDCP is enabled (ON) or disabled (OFF). When set to "ON", copyright-protected (HDCP) video can be input. HDCP is also added to the video that is output. * When you change the setting, the change is not applied until you press the [VALUE] knob to confirm.	
FRAME RATE	60, 59.94, 50, 30, 29.97, 25, 24, 23.976Hz	Specifies the frame rate. * A change in this setting does not take effect until you press the [VALUE] knob to confirm, and then restart the unit.	
SYSTEM FORMAT	1080p , 1080i, 720p	Specifies the system format for the V-8HD. * When you change the setting, the change is not applied until you press the [VALUE] knob to confirm.	
CUT SW ASSIGN	Specifies the function of the [CUT] button.		
	▲ AUTO TAKE	When the video of the B/PST bus is selected, switches to the video of the A/PGM bus.	
	▲ AUTO TAKE ▼	Switches the video between A/PGM bus and B/PST bus.	
	▲ CUT	When the video of the B/PST bus is selected, switches to the video of the A/PGM bus as a cut.	
	▲ CUT ▼	Switches the video between A/PGM bus and B/PST bus as a cut.	
▲ TRANSFORM	Switches to the video of the A/PGM bus as a cut only while you're holding down the button.		
AUTO SW ASSIGN	Specifies the function of the [AUTO] button.		
	AUTO TAKE ▼	When the video of the A/PGM bus is selected, switches to the video of the B/PST bus.	
	▲ AUTO TAKE ▼	Switches the video between A/PGM bus and B/PST.	
	CUT ▼	When the video of the A/PGM bus is selected, switches to the video of the B/PST bus as a cut.	
	▲ CUT ▼	Switches the video between A/PGM bus and B/PST as a cut.	
TRANSFORM ▼	Switches to the video of the B/PST bus as a cut only while you're holding down the button.		
PANEL OPERATION	A/B , PGM/PST	Specifies the operation mode for video transitions.	
EFFECTS TRANSITION SYNC	OFF , ON	Sets whether the PinP/DSK composites are switched on and off in tandem with the video transitions. When this is "ON", the PinP/DSK composition turn on/off in tandem with the video transitions. The composited result that is previewed is sent to final output when transitioning to a different video.	
PANEL LOCK	ENTER	Displays the following PANEL LOCK menu.	
	Enable (ON) or disable (OFF) the panel lock.		
	Menu item	Value (Bold: default)	Explanation
	ALL SW & VOLUME	OFF , ON	Turns on/off the settings of the following buttons and knobs in a single action.
	A/PGM 1-8 SW	OFF , ON	Cross-point A [1]-[8] buttons
	B/PST 1-8 SW	OFF , ON	Cross-point B [1]-[8] buttons
	CUT SW	OFF , ON	[CUT] button
	AUTO SW	OFF , ON	[AUTO] button
	MODE SW	OFF , ON	[MODE] button
	AUX SW	OFF , ON	AUX [1]-[8] buttons
	PinP 1 SOURCE SW	OFF , ON	PinP 1 [1]-[8] buttons
	PinP 2 SOURCE SW	OFF , ON	PinP 2 [1]-[8] buttons
	MEMORY SW	OFF , ON	MEMORY [1]-[8] buttons
	MACRO SW	OFF , ON	AUX / PinP SOURCE / MEMORY [1]-[8] buttons
	TRANSITION SW	OFF , ON	[TRANSITION] button
	VIDEO FADER	OFF , ON	Video fader
	SPLIT/VFX A BLOCK	OFF , ON	SPLIT/VFX [A] knob/button
	SPLIT/VFX B BLOCK	OFF , ON	SPLIT/VFX [B] knob/button
	PinP 1 BLOCK	OFF , ON	PinP 1's [POSITION H] knob, [POSITION V] knob, [PVW] button, [ON] button
	PinP 2 BLOCK	OFF , ON	PinP 2's [POSITION H] knob, [POSITION V] knob, [PVW] button, [ON] button
	DSK BLOCK	OFF , ON	DSK's [LEVEL] knob, [GAIN] knob, [PVW] button, [ON] button
	USER 1 SW	OFF , ON	USER [1] button
	USER 2 SW	OFF , ON	USER [2] button
CAPTURE IMAGE SW	OFF , ON	[CAPTURE IMAGE] button	
OUTPUT FADE	OFF , ON	[OUTPUT FADE] knob	

Menu item	Value (Bold: default)	Explanation	
AUX LINKED PGM	Specifies whether the same video as the PGM bus is sent to the AUX bus (AUX link).		
	OFF	Use the AUX [1]–[8] buttons to select the video of the AUX bus.	
	AUTO LINK MANUAL LINK	AUX link is enabled, and the same video as the PGM bus is sent to the AUX bus. Temporarily disabling AUX link When you press an AUX [1]–[8] button, the selection of the AUX [1]–[8] button is enabled (lit green). Re-enabling AUX link	
	AUTO LINK MANUAL LINK	When you operate the [AUTO] button etc. to switch the video of the PGM bus, AUX link is automatically enabled. When you press the AUX [1]–[8] button that is currently selected (lit green), AUX link is enabled.	
OUTPUT FADE ASSIGN	Specifies the functions that occur when you turn the [OUTPUT FADE] knob to the left (TURN LEFT) or to the right (TURN RIGHT).		
TURN LEFT TURN RIGHT	BLACK	Fade out to black.	
	WHITE	Fade out to white.	
	AUDIO	Adjust the volume of the output audio.	
	BLACK&AUDIO (TURN LEFT)	Simultaneously apply the fade-to-black and the output audio volume adjustment functions.	
	WHITE&AUDIO (TURN RIGHT)	Simultaneously apply the fade-to-white and the output audio volume adjustment functions.	
	STILL 1–8 OUTPUT	Outputs the specified still image.	
USER 1 SW USER 2 SW	Specifies the function of the USER [1] [2] buttons.		
ASSIGN	CATEGORY	VALUE	Explanation
	N/A	---	No function is assigned.
	FREEZE (USER 1)	---	Turns the freeze function on/off.
	AUTO SWITCHING (USER 2)	AUTO SWITCHING SW	Turns the auto switching function on/off.
		BPM TAP	If AUTO SWITCHING is “BPM SYNC”, you can set the BPM according to the tempo at which you press the button.
	INPUT ASSIGN	INPUT 1–8	Each time you press a button, the video source of the specified input channel switches.
	STILL OUTPUT	STILL 1–8	Pauses the normal output, and preview/final outputs a cut of the still image.
	AUDIO INPUT MUTE	HDMI 1–8, AUDIO IN	Turns the mute function on/off for the input audio.
	AUDIO OUTPUT MUTE	MASTER OUTPUT, AUX	Turns the mute function on/off for the output audio.
	INPUT SCAN	NORMAL	Each time you press a button, the final output switches from INPUT 1–8 in sequential order.
		REVERSE	Each time you press a button, the final output switches from INPUT 1–8 in reverse order.
	MEMORY SCAN N	NORMAL	Each time you press a button, preset memories 1–24 are recalled in sequential order.
		REVERSE	Each time you press a button, preset memories are recalled in reverse order from 24 through 1.
	REC CONTROL	---	Controls the recorder’s video record start/stop if a recorder that supports HDMI REC TRIGGER functionality is connected.
	SEQUENCER	MODE ON/OFF	Turns sequencer function on/off.
		NEXT	When the sequencer function is on, the same operation as when you press the [AUTO] button.
PREVIOUS		When the sequencer function is on, the same operation as when you press the [CUT] button.	
AUTO SEQUENCE		Turns the auto sequence function on/off.	
LED DIMMER	1–8	Adjusts the brightness when the buttons or indicators are lit.	
LCD DIMMER	1–8	Adjusts the brightness of this unit’s display.	
ON SCREEN MENU	UPPER LEFT , UPPER RIGHT, LOWER LEFT, LOWER RIGHT	Specifies the location of the OSD menu displayed on the multi-view monitor.	
TALLY FRAME	OFF, ON	Specifies whether the tally frame is visible (ON) or hidden (OFF) in the multi-view monitor.	

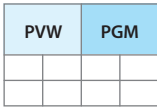
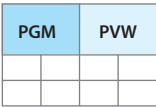
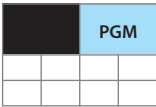
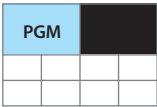
Menu item	Value (Bold: default)	Explanation												
AUX/PinP INDICATOR	OFF, ON	If this is "ON", a symbol is shown in the CH 1–8 section of the multi-view monitor.												
		<table border="1"> <thead> <tr> <th>[MODE] button</th> <th>Mark color</th> <th>Explanation</th> </tr> </thead> <tbody> <tr> <td>AUX</td> <td>Green</td> <td>Input channel being sent to the AUX bus</td> </tr> <tr> <td>PinP 1 SOURCE</td> <td>Yellow</td> <td>Input channel specified as the PinP 1 source image</td> </tr> <tr> <td>PinP 2 SOURCE</td> <td>Magenta</td> <td>Input channel specified as the PinP 2 source image</td> </tr> </tbody> </table>	[MODE] button	Mark color	Explanation	AUX	Green	Input channel being sent to the AUX bus	PinP 1 SOURCE	Yellow	Input channel specified as the PinP 1 source image	PinP 2 SOURCE	Magenta	Input channel specified as the PinP 2 source image
		[MODE] button	Mark color	Explanation										
		AUX	Green	Input channel being sent to the AUX bus										
PinP 1 SOURCE	Yellow	Input channel specified as the PinP 1 source image												
PinP 2 SOURCE	Magenta	Input channel specified as the PinP 2 source image												
REC INDICATOR	OFF, ON	Specifies whether a REC indicator is shown (ON) or not shown (OFF) to indicate that the REC button has been pressed on a connected camera that supports the HDMI REC TRIGGER function.												
AUDIO LEVEL METER	OFF, ON	Specifies whether the audio level meter is shown (ON) or not shown (OFF) in the multi-view monitor.												
AUDIO IN	OFF , LOWER, UPPER	Specifies whether the AUDIO IN audio level meter is shown (LOWER or UPPER) or not shown (OFF).												
MULTI-VIEW LABEL	OFF, ON	Specifies whether the label is shown (ON) or not shown (OFF) in the multi-view monitor.												
MULTI-VIEW LABEL EDIT	HDMI 1–8 , STILL 1–8, PROGRAM, PREVIEW, AUX	Edit the label name shown in the multi-view monitor. Press the [VALUE] knob to access the MULTI-VIEW LABEL EDIT screen.												
MULTI-VIEW LABEL SIZE	SMALL, NORMAL	Specifies the text size of the label shown in the multi-view monitor.												
MULTI-VIEW LAYOUT	Specifies the screen layout of the PVW section and PGM section shown in the multi-view monitor.													
	PVW.PGM	PGM.PVW	BLACK.PGM	PGM.BLACK										
														
		The PVW section is not shown.	The PVW section is not shown.											
OUTPUT 3 OSD	ENTER		Displays the following OUTPUT 3 OSD menu.											
	Menu item	Value (Bold: default)	Explanation											
	ON SCREEN MENU	OFF, ON	Specifies whether the menu is shown (ON) or not shown (OFF).											
	TALLY FRAME	OFF, ON	Specifies whether the tally frame is visible (ON) or hidden (OFF) in the multi-view monitor. * This is valid when "OUTPUT ASSIGN" is set to "MULTI-VIEW".											
LABEL/LEVEL METER/MARK	OFF, ON	Specifies whether the "label", "audio level meter", "AUX indicator", and "REC indicator" of the multi-view monitor are shown (ON) or not shown (OFF). * This is valid when "OUTPUT ASSIGN" is set to "MULTI-VIEW".												
AUTO INPUT DETECT	OFF , ON	Turns the auto input detect function on/off. If this is "ON", and the video that is being output as the program disappears, the program automatically switches to another input video.												
AUTO OFF	OFF, ON	Turns the Auto Off function on/off. If this is "ON", the power to the V-8HD turns off automatically when all of the following states persist for 240 minutes. <ul style="list-style-type: none"> No operation performed on the V-8HD No audio or video input No equipment is connected to the OUTPUT connectors 												
TEST PATTERN	Specifies the test pattern.													
	OFF , 75% COLOR BAR, 100% COLOR BAR, RAMP, STEP, HATCH		Selects the test pattern to display.											
	DISABLE , SLOW, FAST		Specifies the scroll speed of the test pattern.											
TEST TONE	Specifies the test tone.													
LEVEL	OFF , -20dB, -10dB, 0dB		Specifies the volume level of the test tone.											
FREQUENCY L	400Hz, 1kHz , 2kHz		Specifies the frequency of the test tone for the L-channel.											
FREQUENCY R	400Hz, 1kHz , 2kHz		Specifies the frequency of the test tone for the R-channel.											
VIDEO FADER CALIBRATE	ENTER		Displays the VIDEO FADER SET screen. Following the instructions on the screen, calibrate (adjust) the video fader. In some cases, because of continued use or transport, the video output might not reach 100% even if you slide the video fader all the way to the top or bottom. Execute video fader calibration in this case as well.											
FACTORY RESET	EXEC		Returns the unit to its factory defaults.											
VERSION	—		Displays the version of the system program.											

List of Shortcut Keys

You can set the following items without showing a menu.

Menu item	Operation	Remarks
MIX/WIPE		
MIX TYPE	Hold down the [TRANSITION] button and turn the SPLIT/VFX [A] knob	TRANSITION TYPE: MIX
WIPE TYPE	Hold down the [TRANSITION] button and turn the SPLIT/VFX [A] knob	TRANSITION TYPE: WIPE
WIPE DIRECTION	Hold down the [TRANSITION] button and turn the SPLIT/VFX [B] knob	
WIPE BORDER COLOR	Hold down the [TRANSITION] button and turn the SPLIT/VFX [A] knob while pressing	
WIPE BORDER WIDTH	Hold down the [TRANSITION] button and turn the SPLIT/VFX [B] knob while pressing	
SPLIT/VFX A		
SPLIT/VFX TYPE	Hold down the SPLIT/VFX [A] button and turn the SPLIT/VFX [A] knob	
AREA SIZE	Hold down a Cross-point A [1]–[8] button and turn the SPLIT/VFX [A] knob	VFX/SPLIT TYPE : PART MOSAIC, BACKGROUND MOSAIC
BLOCK SIZE	Hold down a Cross-point A [1]–[8] button and turn the SPLIT/VFX [A] knob while pressing	
CENTER POSITION	Turn while pressing the SPLIT/VFX [A] knob	VFX/SPLIT TYPE : SPLIT V, SPLIT H
SPLIT/VFX B		
SPLIT/VFX TYPE	Hold down the SPLIT/VFX [B] button and turn the SPLIT/VFX [A] knob	
AREA SIZE	Hold down a Cross-point B [1]–[8] button and turn the SPLIT/VFX [B] knob	VFX/SPLIT TYPE : PART MOSAIC, BACKGROUND MOSAIC
BLOCK SIZE	Hold down a Cross-point B [1]–[8] button and turn the SPLIT/VFX [B] knob while pressing	
CENTER POSITION	Turn while pressing the SPLIT/VFX [B] knob	VFX/SPLIT TYPE : SPLIT V, SPLIT H
INPUT 1–8		
INPUT ASSIGN	Hold down the [EXIT] button and press a Cross-point A or B [1]–[8] button	Switches the still image (STILL 1–8) assigned to each input channel
OUTPUT 3		
OUTPUT ASSIGN	Hold down the [EXIT] button and press [TRANSITION] button	Switch in the order of the PGM, PVW, AUX, and MULTI-VIEW bus.

When the shortcut key is operated, the following menu screen is shown.

Menu screen	Operation
DSK	Hold down the DSK [PVW] button and press [MENU] button
PinP 1, PinP 2	Hold down the PinP 1 (PinP 2) [PVW] button and press [MENU] button
SPLIT/VFX A, SPLIT/VFX B	Hold down the SPLIT/VFX [A] or [B] button and press [MENU] button
MIX/WIPE	Hold down the [TRANSITION] button and press [MENU] button

Appendix

Troubleshooting

If you suspect a malfunction, please check the following points. If this does not resolve the problem, contact a nearby Roland Service Center.

Problem	Items to check	Action	Page
Video-related problems			
No picture is input.	Could an AUX/PinP SOURCE/MEMORY [1]–[8] button and cross-point A or B [1]–[8] button be blinking?	Video in a format that differs from the setting on the V-8HD is being input. Set the system format to match the connected device.	p. 8
	Has the video source been correctly assigned to INPUT 1–8?	Specify the video source to assign to INPUT 1–8.	p. 30 p. 65
	Is copyright-protected (HDCP) video being input?	When inputting copyright-protected (HDCP) video signals, set “HDCP” to “ON”.	p. 10
Video from the computer is not displayed.	Is the format of the video output from the computer compatible with the V-8HD’s input formats?	The supported input formats on channels 1 through 6 are 1080p, 1080i, and 720p. Only channels 7 and 8 supports VESA-standard resolutions.	p. 8
Video from the computer is corrupted.	When a rapidly moving video is input from a computer, out-of-sync motion, flicker, or other picture corruption may occur.	This is called “tearing”, and does not indicate an equipment malfunction.	
No picture is output.	Could the [OUTPUT FADE] knob be turned all the way left or right?	If the fade function is assigned to the [OUTPUT FADE] knob, turning the knob all the way to the left or right applies a fade to the final output video. To output the video, set the [OUTPUT FADE] knob to the center position.	p. 33
	Is the display connected correctly?	When outputting copyright-protected (HDCP) video, connect an HDCP-compatible display.	p. 10
“Snowy”-noise video is output.	It is possible that the HDMI signal is not being sent and received correctly.	Reconnect the HDMI cable.	
The colors on the monitor screen connected via HDMI are incorrect.	Do the color space settings of the connected display and of the V-8HD match?	Use VIDEO OUTPUT menu → “OUTPUT 1–3” → “COLOR SPACE” to change the setting.	p. 66
		Depending on the device, the color space might be interlinked with the selection of DVI or HDMI or the selected format. In such cases, changing the color space on the output device might bring about improvement for the problem.	
The edge of the video is cut off on the connected display	Are the display settings compatible?	In the case of HDMI signals, automatic overscan occurs on some displays. Change the display’s settings.	
Compositing a logo or video cannot be accomplished.	Has the correct key type (extraction color) been selected for DSK?	Go to the DSK menu and use “KEY TYPE” to select the key type (extraction color) to match the background color of the logo or video.	p. 23
		Use the [LEVEL] and [GAIN] knobs to adjust the position to just the right degree of extraction for the logo or image.	p. 25
Still-image cannot be imported.	Are you importing a still image whose format and resolution are supported by the V-8HD?	Still images of unsupported formats or resolutions are not recognized. Prepare a still image whose format and resolution are supported by the V-8HD.	p. 30
	Does still image have a proper file name?	Use a file name composed of no more than 8 single-byte alphanumeric characters. Also, be sure to append the “bmp”, “png” or “jpg” file extension. Still images without proper file names are not recognized.	
Audio-related Problems			
No audio is output. Audio volume is low.	Could the volume of the connected amp or speaker be lowered?	Adjust the volume appropriately.	
	Is the volume turned down on the V-8HD?	Adjust each input to an appropriate volume level.	p. 34
	Could the audio be muted?	In the AUDIO INPUT menu, defeat muting.	p. 39
Other Problems			
Buttons and knobs cannot be operated.	Is panel lock turned on?	If the [MENU] button is blinking, panel lock is on. In the SYSTEM menu item “PANEL LOCK”, turn panel lock off.	p. 63
Switching is not complete even when the video fader is moved.	Factors such as continued use and transportation can sometimes cause the video to fail to be switched completely.	Perform calibration of the video fader. Go to the SYSTEM menu, then select and execute “VIDEO FADER CALIBRATE”.	p. 87
A USB flash drive cannot be read.	Has the USB flash drive been formatted on the V-8HD?	You may not be able to normally use USB flash drives on the V-8HD that are formatted on a different device. Be sure to format the media on the V-8HD (in FAT32 format). Operation has been tested for commonly available USB flash drives, but operation of all USB flash drives is not assured. Depending on the manufacturer and type of the USB flash drive, correct operation may not be possible.	p. 60

Main Specifications

Video				
Video Processing	4:2:2 (Y/Pb/Pr), 8-bit			
Input Connectors	INPUT 1-6	HDMI type A x 6 * HDCP supported		
	INPUT 7-8	HDMI type A x 2 * HDCP and Multi-format supported		
Output Connectors	OUTPUT 1-3	HDMI type A x 3 * HDCP supported		
Input Formats	INPUT 1-6	720/59.94p, 720/60p (*1) (*3)		
		720/50p (*1) (*4)		
		1080/59.94i, 1080/60i, 1080/59.94p, 1080/60p, 1080/29.97p, 1080/30p (*2) (*3)		
1080/50i, 1080/50p, 1080/25p (*2) (*4)				
1080/23.98p, 1080/24p (*2)				
* The input interlaced video signal is converted to progressive video signal by internal processing. (*1) SYSTEM FORMAT = 720p (*2) SYSTEM FORMAT = 1080i or 1080p (*3) FRAME RATE = 59.94, 60 Hz, 29.97 Hz, 30 Hz (*4) FRAME RATE = 50 Hz or 25 Hz				
INPUT 7, 8	480/59.94i, 480/59.94p, 720/59.94p, 720/60p, 1080/59.94i, 1080/60i, 1080/59.94p, 1080/60p, 1080/29.97p, 1080/30p (*1)			
	576/50i, 576/50p, 720/50p, 1080/50i, 1080/50p, 1080/25p (*2)			
	1080/23.98p, 1080/24p			
	VGA (640x480/60 Hz)	SVGA (800x600/60 Hz)	XGA (1024x768/60 Hz)	
	WXGA (1280x800/60 Hz)	SXGA (1280x1024/60 Hz)	FWXGA (1366x768/60 Hz)	
	SXGA + (1400x1050/60 Hz)	UXGA (1600x1200/60 Hz)	WUXGA (1920x1200/60 Hz)	
* The refresh rate is the maximum value of each resolution. * Conforms to CEA-861-E, VESA DMT Version 1.0 Revision 11. * 1920 x 1200/60 Hz: Reduced blanking * The input interlaced video signal is converted to progressive video signal by internal processing. (*1) FRAME RATE = 59.94 Hz, 60 Hz, 29.97 Hz, 30 Hz (*2) FRAME RATE = 50 Hz or 25 Hz				
Still Image	Bitmap File (.bmp): Maximum 1920 x 1080 pixels, 24-bit color, uncompressed			
	PNG File (.png): Maximum 1920 x 1080 pixels, 24-bit color			
	JPEG File (.jpg, .jpeg): Maximum 1920 x 1080 pixels, 24-bit color			
* It can be stored up to 24 files in the internal memory. * It can be exported in the USB flash drive. * PNG alpha channel supported (Exclusive with alpha bus or AUX bus).				
Output Formats	OUTPUT 1, 2	720/59.94p (*1) (*4)	720/60p (*1) (*5)	720/50p (*1) (*8)
		1080/59.94i (*2) (*4)	1080/60i (*2) (*5)	1080/50i (*2) (*8)
		1080/59.94p (*3) (*4)	1080/60p (*3) (*5)	1080/29.97p (*3) (*6)
		1080/30p (*3) (*7)	1080/50p (*3) (*8)	1080/25p (*3) (*9)
		1080/23.98p (*3) (*10)	1080/24p (*3) (*11)	
		(*1) SYSTEM FORMAT = 720p (*7) FRAME RATE = 30 Hz (*2) SYSTEM FORMAT = 1080i (*8) FRAME RATE = 50 Hz (*3) SYSTEM FORMAT = 1080p (*9) FRAME RATE = 25 Hz (*4) FRAME RATE = 59.94 Hz (*10) FRAME RATE = 23.98 Hz (*5) FRAME RATE = 60 Hz (*11) FRAME RATE = 24 Hz (*6) FRAME RATE = 29.97 Hz		
	OUTPUT 3	1080/59.94p (*1)	1080/60p (*2)	1080/29.97p (*3)
		1080/30p (*4)	1080/50p (*5)	1080/25p (*6)
		1080/23.98p (*7)	1080/24p (*8)	
		(*1) FRAME RATE = 59.94 Hz (*5) FRAME RATE = 50 Hz (*2) FRAME RATE = 60 Hz (*6) FRAME RATE = 25 Hz (*3) FRAME RATE = 29.97 Hz (*7) FRAME RATE = 23.98 Hz (*4) FRAME RATE = 30 Hz (*8) FRAME RATE = 24 Hz		
Video Effects	Transition	CUT, MIX (DISSOLVE/FAM/NAM), WIPE (8 types)		
	Composition	PinP x 2: SQUARE, CIRCLE, DIAMOND, SPLIT (2 types), Keyer x 2: Luminance Key, Chroma Key DSK: Luminance Key, Chroma Key, Alpha Key (*1), External Key (*1) (*1) Exclusive with alpha bus or AUX bus		
	Others	Flip horizontal, Flip vertical, Still Image Capture, Still Image Playback, Output fade (Audio, Video: WHITE or BLACK), Test pattern output		

■ Audio		
Audio Processing	Sample rate: 24 bits/48 kHz	
Audio Formats	Linear PCM, 24 bits/48 kHz, 2 ch	
Input Connectors	INPUT 1–8	HDMI Type A x 8
	AUDIO IN	RCA phono type
Output Connectors	OUTPUT 1–3	HDMI Type A x 3
	AUDIO OUT	RCA phono type
	PHONES	Stereo miniature type
Input Level	AUDIO IN: -10 dBu (Maximum: +8 dBu)	
Input Impedance	AUDIO IN: 38 kΩ	
Output Level	AUDIO OUT	-10 dBu (Maximum: +8 dBu)
	PHONES	92 mW + 92 mW (32 Ω)
Output Impedance	AUDIO OUT	1 kΩ
	PHONES	10 Ω
Audio Effects	Delay, High pass filter, Compressor, Noise gate, Equalizer, Multi-band compressor, Limiter, Test tone output	
■ Others		
Other Connectors	USB MEMORY	USB A type (for USB flash drive)
	REMOTE	USB B Type (for remote control from PC and iPad)
	CTL/EXP	1/4-inch TRS phone type
Other Functions	Preset Memory (24 types) Macro Control (100 types) Sequencer Control Panel lock function EDID Emulator Auto Switching Auto Input Detect Rec Control	
Display	4.3 inches TFT Color LCD: 480 x 272 dots	
Power Supply	AC Adaptor	
Current Draw	3.3 A	
Power Consumption	39.6 W	
Operation Temperature	+0 to +40 degrees Celsius	
	+32 to +104 degrees Fahrenheit	
Dimensions	317 (W) x 193 (D) x 70 (H) mm	
	12-1/2 (W) x 7-5/8 (D) x 2-13/16 (H) inches	
Weight (excluding AC adaptor)	2.0 kg	
	4 lbs 7 oz	
Accessories	Startup Guide, AC adaptor, Power cord	

* 0 dBu = 0.775 Vrms

* This document explains the specifications of the product at the time that the document was issued. For the latest information, refer to the Roland website.

Dimensions

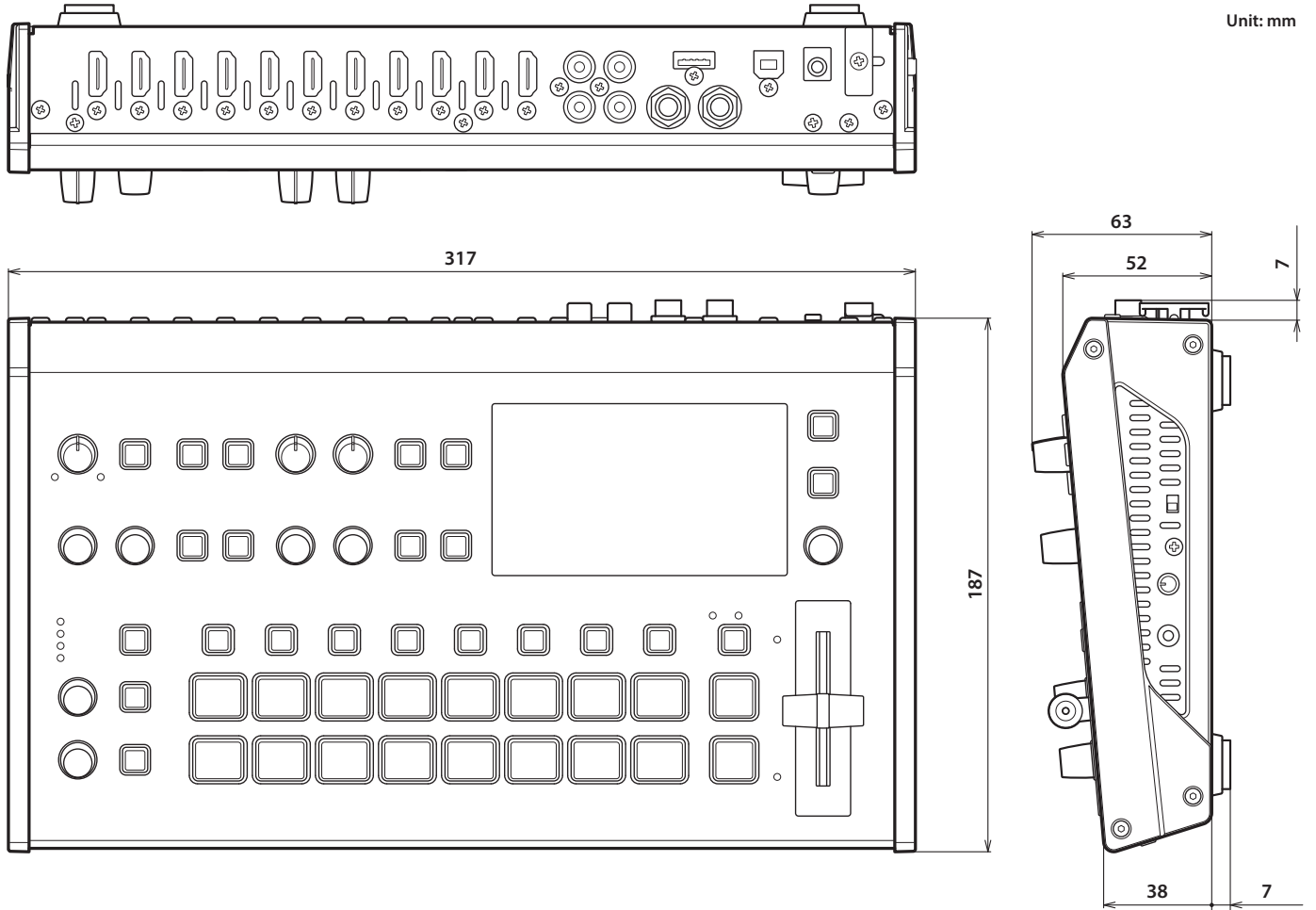

MIDI Implementation

Model: V-8HD
Date: October 8, 2021
Version: 2.00

Symbol	Item	Setting Range
n	MIDI Channel	Fixed at 00H

1. MIDI Messages Received at MIDI IN

Channel Voice Messages

Control Change

○ Panpot (Controller Number 10)

This control the position of video fader.

Status	2nd Byte	3rd Byte
BnH	0AH	vvH

vv = 00H–7FH (00H: bottom edge, 7FH: top edge)

○ Expression (Controller Number 11)

This control the value of TRANSITION TYPE.

Status	2nd Byte	3rd Byte
BnH	0BH	vvH

vv = 00H–03H (MIX, WIPE)

○ Effect Control 1 (Controller Number 12)

This control the value of MIX/WIPE TIME.

Status	2nd Byte	3rd Byte
BnH	0CH	vvH

vv = 00H–28H (0.0–4.0sec)

○ Effect Control 2 (Controller Number 13)

This control the value of PinP 1 TIME.

Status	2nd Byte	3rd Byte
BnH	0DH	vvH

vv = 00H–28H (0.0–4.0sec)

○ Undefined (Controller Number 14)

This control the value of PinP 2 TIME.

Status	2nd Byte	3rd Byte
BnH	0EH	vvH

vv = 00H–28H (0.0–4.0sec)

○ Undefined (Controller Number 15)

This control the value of DSK TIME.

Status	2nd Byte	3rd Byte
BnH	0FH	vvH

vv = 00H–28H (0.0–4.0sec)

○ General Purpose Controllers 1 (Controller Number 16)

This control the value of PinP 1 SOURCE.

Status	2nd Byte	3rd Byte
BnH	10H	vvH

vv = 00H–0FH (HDMI 1–8, STILL 1–8)

○ General Purpose Controllers 2 (Controller Number 17)

This control the value of PinP 1 POSITION H.

Status	2nd Byte	3rd Byte
BnH	11H	vvH

vv = 0AH–64H (-50–50%)

○ General Purpose Controllers 3 (Controller Number 18)

This control the value of PinP 1 POSITION V.

Status	2nd Byte	3rd Byte
BnH	12H	vvH

vv = 0AH–64H (-50–50%)

○ General Purpose Controllers 4 (Controller Number 19)

This control the value of PinP 1 SIZE.

Status	2nd Byte	3rd Byte
BnH	13H	vvH

vv = 0AH–64H (10–100%)

○ Undefined (Controller Number 20)

This control the value of PinP 1 VIEW ZOOM.

Status	2nd Byte	3rd Byte
BnH	14H	vvH

vv = 0AH–64H (100–1000%)

○ Undefined (Controller Number 21)

This control the value of PinP 2 SOURCE.

Status	2nd Byte	3rd Byte
BnH	15H	vvH

vv = 00H–0FH (HDMI 1–8, STILL 1–8)

○ Undefined (Controller Number 22)

This control the value of PinP 2 POSITION H.

Status	2nd Byte	3rd Byte
BnH	16H	vvH

vv = 0AH–64H (-50–50%)

○ Undefined (Controller Number 23)

This control the value of PinP 2 POSITION V.

Status	2nd Byte	3rd Byte
BnH	17H	vvH

vv = 0AH–64H (-50–50%)

○ Undefined (Controller Number 24)

This control the value of PinP 2 SIZE.

Status	2nd Byte	3rd Byte
BnH	18H	vvH

vv = 0AH–64H (10–100%)

○ Undefined (Controller Number 25)

This control the value of PinP 2 VIEW ZOOM.

Status	2nd Byte	3rd Byte
BnH	19H	vvH

vv = 0AH–64H (100–1000%)

○ Undefined (Controller Number 26)

This control the value of DSK SOURCE.

Status	2nd Byte	3rd Byte
BnH	1AH	vvH

vv = 00H–0FH (HDMI 1–8, STILL 1–8)

○ Undefined (Controller Number 27)

This control the value of DSK LEVEL.

Status	2nd Byte	3rd Byte
BnH	1BH	vvH

vv = 00H–7FH (Converted to 0–255)

○ Undefined (Controller Number 28)

This control the value of DSK GAIN.

Status	2nd Byte	3rd Byte
BnH	1CH	vvH

vv = 00H–7FH (Converted to 0–255)

○ Undefined (Controller Number 29)

This control the value of DSK MIX LEVEL.

Status	2nd Byte	3rd Byte
BnH	1DH	vvH

vv = 00H–7FH (Converted to 0–255)

○ Undefined (Controller Number 30)

This control the value of SPLIT/VFX A SW.

Status	2nd Byte	3rd Byte
BnH	1EH	vvH

vv = 00H, 01H (OFF, ON)

○ Undefined (Controller Number 31)

This control the value of SPLIT/VFX A TYPE.

Status	2nd Byte	3rd Byte
BnH	1FH	vvH

vv = 00H–11H (refer to p. 99)

○ Bank select (Controller Number 32)

This control the value of SPLIT/VFX B SW.

Status	2nd Byte	3rd Byte
BnH	20H	vvH

vv = 00H, 01H (OFF, ON)

○ Modulation (Controller Number 33)

This control the value of SPLIT/VFX B TYPE.

Status	2nd Byte	3rd Byte
BnH	21H	vvH

vv = 00H–11H (refer to p. 99)

○ Bless Controller (Controller Number 34)

This control the [OUTPUT FADE] knob position (counter-clockwise)

Status	2nd Byte	3rd Byte
BnH	22H	vvH

vv = 00H–3FH

○ Undefined (Controller Number 35)

This control the [OUTPUT FADE] knob position (clockwise)

Status	2nd Byte	3rd Byte
BnH	23H	vvH

vv = 00H–3FH

○ Foot Controller (Controller Number 36)

This control the value of AUDIO INPUT LEVEL (INPUT 1).

Status	2nd Byte	3rd Byte
BnH	24H	vvH

vv = 00H–7FH (refer to "Control Value–Input/Output Level Correspondence Table" (p. 95))

○ Portamento Time (Controller Number 37)

This control the value of AUDIO INPUT LEVEL (INPUT 2).

Status	2nd Byte	3rd Byte
BnH	25H	vvH

vv = 00H–7FH (refer to "Control Value–Input/Output Level Correspondence Table" (p. 95))

○ Data Entry (Controller Number 38)

This control the value of AUDIO INPUT LEVEL (INPUT 3).

Status	2nd Byte	3rd Byte
BnH	26H	vvH

vv = 00H–7FH (refer to "Control Value–Input/Output Level Correspondence Table" (p. 95))

○ Channel volume (Controller Number 39)

This control the value of AUDIO INPUT LEVEL (INPUT 4).

Status	2nd Byte	3rd Byte
BnH	27H	vvH

vv = 00H–7FH (refer to "Control Value–Input/Output Level Correspondence Table" (p. 95))

○ Balance (Controller Number 40)

This control the value of AUDIO INPUT LEVEL (INPUT 5).

Status	2nd Byte	3rd Byte
BnH	28H	vvH

vv = 00H–7FH (refer to "Control Value–Input/Output Level Correspondence Table" (p. 95))

○ Undefined (Controller Number 41)

This control the value of AUDIO INPUT LEVEL (INPUT 6).

Status	2nd Byte	3rd Byte
BnH	29H	vvH

vv = 00H–7FH (refer to "Control Value–Input/Output Level Correspondence Table" (p. 95))

○ Panpot (Controller Number 42)

This control the value of AUDIO INPUT LEVEL (INPUT 7).

Status	2nd Byte	3rd Byte
BnH	2AH	vvH

vv = 00H–7FH (refer to "Control Value–Input/Output Level Correspondence Table" (p. 95))

○ Expression (Controller Number 43)

This control the value of AUDIO INPUT LEVEL (INPUT 8).

Status	2nd Byte	3rd Byte
BnH	2BH	vvH

vv = 00H–7FH (refer to "Control Value–Input/Output Level Correspondence Table" (p. 95))

○ Effect Control 1 (Controller Number 44)

This control the value of AUDIO INPUT LEVEL (AUDIO IN).

Status	2nd Byte	3rd Byte
BnH	2CH	vvH

vv = 00H–7FH (refer to "Control Value–Input/Output Level Correspondence Table" (p. 95))

○ Effect Control 2 (Controller Number 45)

This control the value of AUDIO OUTPUT LEVEL.

Status	2nd Byte	3rd Byte
BnH	2DH	vvH

vv = 00H–7FH (refer to "Control Value–Input/Output Level Correspondence Table" (p. 95))

○ Undefined (Controller Number 52)

Presses or release the [CUT] button.

Status	2nd Byte	3rd Byte
BnH	34H	vvH

vv = 00H, 01H (OFF, ON)

○ Undefined (Controller Number 53)

Presses release the [AUTO] button.

Status	2nd Byte	3rd Byte
BnH	35H	vvH

vv = 00H, 01H (OFF, ON)

○ Undefined (Controller Number 54)

Switches the video as "▲ CUT ▼".

Status	2nd Byte	3rd Byte
BnH	36H	vvH

vv = any (00H–7FH)

○ Undefined (Controller Number 55)

Switches the video as "▲ AUTO TAKE ▼".

Status	2nd Byte	3rd Byte
BnH	37H	vvH

vv = any (00H–7FH)

Undefined (Controller Number 56)

This control the value of AUDIO INPUT MUTE (INPUT 1).

<u>Status</u>	<u>2nd Byte</u>	<u>3rd Byte</u>
BnH	38H	vvH

vv = 00H, 01H (OFF, ON)

Undefined (Controller Number 57)

This control the value of AUDIO INPUT MUTE (INPUT 2).

<u>Status</u>	<u>2nd Byte</u>	<u>3rd Byte</u>
BnH	39H	vvH

vv = 00H, 02H (OFF, ON)

Undefined (Controller Number 58)

This control the value of AUDIO INPUT MUTE (INPUT 3).

<u>Status</u>	<u>2nd Byte</u>	<u>3rd Byte</u>
BnH	3AH	vvH

vv = 00H, 03H (OFF, ON)

Undefined (Controller Number 59)

This control the value of AUDIO INPUT MUTE (INPUT 4).

<u>Status</u>	<u>2nd Byte</u>	<u>3rd Byte</u>
BnH	3BH	vvH

vv = 00H, 04H (OFF, ON)

Undefined (Controller Number 60)

This control the value of AUDIO INPUT MUTE (INPUT 5).

<u>Status</u>	<u>2nd Byte</u>	<u>3rd Byte</u>
BnH	3CH	vvH

vv = 00H, 05H (OFF, ON)

Undefined (Controller Number 61)

This control the value of AUDIO INPUT MUTE (INPUT 6).

<u>Status</u>	<u>2nd Byte</u>	<u>3rd Byte</u>
BnH	3DH	vvH

vv = 00H, 06H (OFF, ON)

Undefined (Controller Number 62)

This control the value of AUDIO INPUT MUTE (INPUT 7).

<u>Status</u>	<u>2nd Byte</u>	<u>3rd Byte</u>
BnH	3EH	vvH

vv = 00H, 07H (OFF, ON)

Undefined (Controller Number 63)

This control the value of AUDIO INPUT MUTE (INPUT 8).

<u>Status</u>	<u>2nd Byte</u>	<u>3rd Byte</u>
BnH	3FH	vvH

vv = 00H, 08H (OFF, ON)

Hold 1 (Controller Number 64)

This control the value of AUDIO INPUT MUTE (AUDIO IN).

<u>Status</u>	<u>2nd Byte</u>	<u>3rd Byte</u>
BnH	40H	vvH

vv = 00H, 09H (OFF, ON)

Portamento Switch (Controller Number 65)

This control the value of AUDIO OUTPUT MUTE.

<u>Status</u>	<u>2nd Byte</u>	<u>3rd Byte</u>
BnH	41H	vvH

vv = 00H, 10H (OFF, ON)

■ **Control Value–Input/Output Level Correspondence Table (unit: dB)**

0	-Inf	32	-33.1	64	-11.3	96	-0.3
1	-80.0	33	-32.3	65	-10.7	97	0.0
2	-76.7	34	-31.5	66	-10.3	98	0.3
3	-73.3	35	-30.8	67	-10.0	99	0.7
4	-70.0	36	-30.0	68	-9.7	100	1.0
5	-66.7	37	-29.3	69	-9.3	101	1.3
6	-63.3	38	-28.7	70	-9.0	102	1.7
7	-60.0	39	-28.0	71	-8.7	103	2.0
8	-58.6	40	-27.3	72	-8.3	104	2.3
9	-57.1	41	-26.7	73	-8.0	105	2.7
10	-55.7	42	-26.0	74	-7.7	106	3.0
11	-54.3	43	-25.3	75	-7.3	107	3.3
12	-52.9	44	-24.7	76	-7.0	108	3.7
13	-51.4	45	-24.0	77	-6.7	109	4.0
14	-50.0	46	-23.3	78	-6.3	110	4.3
15	-48.9	47	-22.7	79	-6.0	111	4.7
16	-47.8	48	-22.0	80	-5.7	112	5.0
17	-46.7	49	-21.3	81	-5.3	113	5.3
18	-45.6	50	-20.7	82	-5.0	114	5.7
19	-44.4	51	-20.0	83	-4.7	115	6.0
20	-43.3	52	-19.3	84	-4.3	116	6.3
21	-42.2	53	-18.7	85	-4.0	117	6.7
22	-41.1	54	-18.0	86	-3.7	118	7.0
23	-40.0	55	-17.3	87	-3.3	119	7.3
24	-39.2	56	-16.7	88	-3.0	120	7.7
25	-38.5	57	-16.0	89	-2.7	121	8.0
26	-37.7	58	-15.3	90	-2.3	122	8.3
27	-36.9	59	-14.7	91	-2.0	123	8.7
28	-36.2	60	-14.0	92	-1.7	124	9.0
29	-35.4	61	-13.3	93	-1.3	125	9.3
30	-34.6	62	-12.7	94	-1.0	126	9.7
31	-33.8	63	-12.0	95	-0.7	127	10.0

● **Program Change**

This message recalls a preset memory.

<u>Status</u>	<u>2nd Byte</u>
CnH	ppH

pp = Memory number: 00H–07H (MEMORY 1–MEMORY 8)

■ System Exclusive Messages

<u>Status</u>	<u>Data Byte</u>	<u>Status</u>
F0H	iiH, ddH, ..., eeH	F7H
F0H:	Status of system exclusive message	
ii= ID number:	This is the ID to recognize manufacturer of the exclusive message (manufacturer ID). The manufacturer ID of Roland is 41H. The ID numbers of 7EH and 7FH are expansion of MIDI standards and used as universal non-realtime message (7EH) of universal realtime message (7FH).	
dd, ..., ee= data:	00H–7FH (0–127)	
F7H:	EOX (end of exclusive)	

● Data Request 1 (RQ1)

This is the message to request of "send data" to the connected device. Specify data type and amount using address and size. When this is received, the unit sends the requested data as "Data Set 1 (DT1)" message in case the unit is in status where the sending of data is possible and requested address and size are appropriate. If not, the unit sends nothing.

<u>Status</u>	<u>Data Byte</u>	<u>Status</u>
F0H	41H, 10H, 00H, 00H, 00H, 68H, 11H, aaH, bbH, ccH, ssH, ttH, uuH, sum	F7H
<u>Byte</u>	<u>Explanation</u>	
F0H	Exclusive Status	
41H	Manufacturer ID (Roland)	
10H	Device ID	
00H	1st byte of model ID (V-8HD)	
00H	2nd byte of model ID (V-8HD)	
00H	3rd byte of model ID (V-8HD)	
68H	4th byte of model ID (V-8HD)	
11H	Command ID (RQ1)	
aaH	Address upper byte	
bbH	Address middle byte	
ccH	Address lower byte	
ssH	Size upper byte	
ttH	Size middle byte	
uuH	Size lower byte	
sum	Checksum	
F7H	EOX (end of exclusive)	

* Depending on the data type, the amount of single-time transmission is specified. It is necessary to execute data request according to the specified first address and size. Refer to the "2. Parameter Address Map" (p. 97) for address and size.

* See "Example of an Exclusive Message and Calculating a Checksum" (p. 107) for checksum.

● Data Set 1 (DT1)

This is the message of actual data transmission. Use this when you want to set data to the unit.

<u>Status</u>	<u>Data Byte</u>	<u>Status</u>
F0H	41H, 10H, 00H, 00H, 00H, 68H, 12H, aaH, bbH, ccH, ddH, ..., eeH, sum	F7H
<u>Byte</u>	<u>Explanation</u>	
F0H	Exclusive Status	
41H	Manufacturer ID (Roland)	
10H	Device ID	
00H	1st byte of model ID (V-8HD)	
00H	2nd byte of model ID (V-8HD)	
00H	3rd byte of model ID (V-8HD)	
68H	4th byte of model ID (V-8HD)	
12H	Command ID (DT1)	
aaH	Address upper byte	
bbH	Address middle byte	
ccH	Address lower byte	
ddH	Data: actual data to transmit. Multiple byte data is sent in address order.	
:	:	
eeH	Data	
sum	Checksum	
F7H	EOX (end of exclusive)	

* Depending on the data type, the amount of single-time transmission is specified. It is necessary to execute data request according to the specified first address and size. Refer to the "2. Parameter Address Map" (p. 97) for address and size.

* See "Example of an Exclusive Message and Calculating a Checksum" (p. 107) for checksum.

* Data exceeding 256 bytes should be divided into packets of 256 bytes or smaller. If you send data set 1 successively, set interval of 20 ms or longer between packets.

2. Parameter Address Map

Start Address	Description
00H 00H 00H	Video Parameter Area
01H 00H 00H	Audio Parameter Area
02H 00H 00H	System Parameter Area
0AH 00H 00H	Other Parameter Area
0CH 00H 00H	Tally Parameter Area
10H 00H 00H	Video Parameter (Memory 1)
11H 00H 00H	Audio Parameter (Memory 1)
12H 00H 00H	Video Parameter (Memory 2)
13H 00H 00H	Audio Parameter (Memory 2)
14H 00H 00H	Video Parameter (Memory 3)
15H 00H 00H	Audio Parameter (Memory 3)
16H 00H 00H	Video Parameter (Memory 4)
17H 00H 00H	Audio Parameter (Memory 4)

Start Address	Description
18H 00H 00H	Video Parameter (Memory 5)
19H 00H 00H	Audio Parameter (Memory 5)
1AH 00H 00H	Video Parameter (Memory 6)
1BH 00H 00H	Audio Parameter (Memory 6)
1CH 00H 00H	Video Parameter (Memory 7)
1DH 00H 00H	Audio Parameter (Memory 7)
1EH 00H 00H	Video Parameter (Memory 8)
1FH 00H 00H	Audio Parameter (Memory 8)
:	:
3EH 00H 00H	Video Parameter (Memory 24)
3FH 00H 00H	Audio Parameter (Memory 24)
60H 00H 00H	Preset Memoey Name Area

● Video Parameter Area

○ Video Input

* "xxH" corresponds to the respective channels as indicated below.
xxH: 00H–05H (CH1–CH6)

Address	Parameter Name	Sys.Ex.Value	Meaning of Value
00H xxH 00H	INPUT ASSIGN	00H–08H	HDMI, STILL 1–8
00H xxH 01H	FLIP H	00H–01H	OFF, ON
00H xxH 02H	FLIP V	00H–01H	OFF, ON
00H xxH 03H	BRIGHTNESS	60H–00H–1FH	-32–0–31
00H xxH 04H	CONTRAST	60H–00H–1FH	-32–0–31
00H xxH 05H	SATURATION	60H–00H–1FH	-32–0–31

○ Video Input (SCALER)

* "xxH" corresponds to the respective channels as indicated below.
xxH: 06H–05H (CH7–CH8)

Address	Parameter Name	Sys.Ex.Value	Meaning of Value
00H xxH 00H	INPUT ASSIGN	00H–08H	HDMI, STILL 1–8
00H xxH 01H	FLICKER FILTER	00H–01H	OFF, ON
00H xxH 02H	FLIP H	00H–01H	OFF, ON
00H xxH 03H	FLIP V	00H–01H	OFF, ON
00H xxH 04H	EDID	00H–0BH	INTERNAL, SVGA (800x600), XGA (1024x768), WXGA (1280x800), FWXGA (1366x768), SXGA (1280x1024), SXGA + (1400x1050), UXGA (1600x1200), WUXGA (1920x1200), 720p, 1080i, 1080p
00H xxH 05H 06H	ZOOM	00H 64H–4EH 10H	10.0–1000.0%
00H xxH 07H	SCALING TYPE	00H–04H	FULL, LETTERBOX, CROP, DOT BY DOT, MANUAL
00H xxH 08H 09H	MANUAL SIZE H	70H 30H–00H –0FH 50H	-2000–0–2000
00H xxH 0AH 0BH	MANUAL SIZE V	70H 30H–00H–0FH 50H	-2000–0–2000
00H xxH 0CH 0DH	POSITION H	71H 00H–00H–0FH 00H	-1920–0–1920
00H xxH 0EH 0FH	POSITION V	76H 50H–00H–09H 30H	-1200–0–1200
00H xxH 10H	BRIGHTNESS	60H–00H–1FH	-32–0–31
00H xxH 11H	CONTRAST	60H–00H–1FH	-32–0–31
00H xxH 12H	SATURATION	60H–00H–1FH	-32–0–31
00H xxH 13H	RED	40H–00H–3FH	-64–0–63
00H xxH 14H	GREEN	40H–00H–3FH	-64–0–63
00H xxH 15H	BLUE	40H–00H–3FH	-64–0–63

○ Video Output

* "xxH" corresponds to the respective channels as indicated below.
xxH: 08H-0AH (OUTPUT 1-3)

Address	Parameter Name	Sys.Ex.Value	Meaning of Value
00H xxH 00H	OUTPUT ASSIGN	00H-03H	PROGRAM, PREVIEW, AUX, MULTI VIEW
00H xxH 01H	COLOR SPACE	00H-02H	YPbPr, RGB (0-255), RGB (16-235)
00H xxH 02H	DVI-D/HDMI SIGNAL	00H-01H	HDMI, DVI-D
00H xxH 03H	BRIGHTNESS	40H-00H-3FH	-64-0-63
00H xxH 04H	CONTRAST	40H-00H-3FH	-64-0-63
00H xxH 05H	SATURATION	40H-00H-3FH	-64-0-63
00H xxH 06H	RED	40H-00H-3FH	-64-0-63
00H xxH 07H	GREEN	40H-00H-3FH	-64-0-63
00H xxH 08H	BLUE	40H-00H-3FH	-64-0-63
00H xxH 09H	REC CONTROL	00H-01H	OFF, ON

○ TRANSITION TIME

Address	Parameter Name	Sys.Ex.Value	Meaning of Value
00H 0BH 00H	MIX/WIPE TIME	00H-28H	0.0-4.0sec
00H 0BH 01H	PinP 1 TIME	00H-28H	0.0-4.0sec
00H 0BH 02H	PinP 2 TIME	00H-28H	0.0-4.0sec
00H 0BH 03H	DSK TIME	00H-28H	0.0-4.0sec

○ MIX/WIPE

Address	Parameter Name	Sys.Ex.Value	Meaning of Value
00H 0CH 00H	TRANS TYPE	00H-01H	MIX, WIPE
00H 0CH 01H	MIX TYPE	00H-02H	MIX, FAM, NAM
00H 0CH 02H	WIPE TYPE	00H-07H	HORIZONTAL, VERTICAL, UPPER LEFT, UPPER RIGHT, LOWER LEFT, LOWER RIGHT, H-CENTER, V-CENTER
00H 0CH 03H	WIPE DIRECTION	00H-02H	NORMAL, REVERSE, ROUND TRIP
00H 0CH 04H	WIPE BORDER COLOR	00H-08H	WHITE, YELLOW, CYAN, GREEN, MAGENTA, RED, BLUE, BLACK, SOFT EDGE
00H 0CH 05H	WIPE BORDER WIDTH	00H-0EH	0-14

○ PinP

* "xxH" corresponds to the respective channels as indicated below.
xxH: 0DH-0EH (PinP 1, 2)

Address	Parameter Name	Sys.Ex.Value	Meaning of Value
00H xxH 00H	PGM SW	00H-01H	OFF, ON
00H xxH 01H	PVW SW	00H-01H	OFF, ON
00H xxH 02H	SOURCE	00H-0FH	HDMI1-8, STILL1-8
00H xxH 03H	TYPE	00H-03H	PinP, LUMINANCE-WHITE KEY, LUMINANCE-BLACK KEY, CHROMA KEY
00H xxH 04H 05H	POSITION H	7CH 0CH-00H 00H-03H 74H	-50.0-0.0-50.0%
00H xxH 06H 07H	POSITION V	7CH 0CH-00H 00H-03H 74H	-50.0-0.0-50.0%
00H xxH 08H 09H	SIZE	00H 64H-07H 68H	10.0-100.0%
00H xxH 0AH 0BH	CROPPING H	00H 00H-07H 68H	0.0-100.0%
00H xxH 0CH 0DH	CROPPING V	00H 00H-07H 68H	0.0-100.0%
00H xxH 0EH	SHAPE	00H-02H	RECTANGLE, CIRCLE, DIAMOND
00H xxH 0FH	BORDER COLOR	00H-08H	WHITE, YELLOW, CYAN, GREEN, MAGENTA, RED, BLUE, BLACK, SOFT EDGE
00H xxH 10H	BORDER WIDTH	00H-0EH	0-14
00H xxH 11H 12H	VIEW POSITION H	00H 64H-07H 68H	10.0-100.0%
00H xxH 13H 14H	VIEW POSITION V	00H 64H-07H 68H	10.0-100.0%
00H xxH 15H 16H	VIEW ZOOM	00H 64H-03H 10H	100-400%
00H xxH 17H 18H	KEY LEVEL	00H 00H-01H 7FH	0-255
00H xxH 19H 1AH	KEY GAIN	00H 00H-01H 7FH	0-255
00H xxH 1BH 1CH	MIX LEVEL	00H 00H-01H 7FH	0-255
00H xxH 1DH	CHROMA COLOR	00H-01H	GREEN, BLUE
00H xxH 1EH	HUE WIDTH	62H-00H-1EH	-30-0-30

Address	Parameter Name	Sys.Ex.Value	Meaning of Value
00H xxH 1FH 20H	HUE FINE	00H 00H-02H 68H	0-360
00H xxH 21H 22H	SATURATION WIDTH	7FH 00H-00H 00H-00H 7FH	-128-0-127
00H xxH 23H 24H	SATURATION FINE	00H 00H-01H 7FH	0-255
00H xxH 25H	FILL TYPE	00H-01H	BUS, MATTE
00H xxH 26H	MATTE COLOR	00H-07H	WHITE, YELLOW, CYAN, GREEN, MAGENTA, RED, BLUE, BLACK
00H xxH 27H	EDGE TYPE	00H-04H	OFF, BORDER, DROP, SHADOW, OUTLINE
00H xxH 28H	EDGE COLOR	00H-07H	WHITE, YELLOW, CYAN, GREEN, MAGENTA, RED, BLUE, BLACK
00H xxH 29H	EDGE WIDTH	00H-0EH	0-14

○ DSK

Address	Parameter Name	Sys.Ex.Value	Meaning of Value
00H 0FH 00H	PGM SW	00H-01H	OFF, ON
00H 0FH 01H	PVW SW	00H-01H	OFF, ON
00H 0FH 02H	FILL SOURCE	00H-0FH	HDMI 1-8, STILL 1-8
00H 0FH 03H	TYPE	00H-02H	LUMINANCE-WHITE, LUMINANCE-BLACK, CHROMA
00H 0FH 04H 05H	DSK LEVEL	00H 00H-01H 7FH	0-255
00H 0FH 06H 07H	DSK GAIN	00H 00H-01H 7FH	0-255
00H 0FH 08H 09H	MIX LEVEL	00H 00H-01H 7FH	0-255
00H 0FH 0AH	CHROMA COLOR	00H-01H	GREEN, BLUE
00H 0FH 0BH	HUE WIDTH	62H-00H-1EH	-30-0-30
00H 0FH 0CH 0DH	HUE FINE	00H 00H-02H 68H	0-360
00H 0FH 0EH 0FH	SATURATION WIDTH	7FH 00H-00H 00H-00H 7FH	-128-0-127
00H 0FH 10H 11H	SATURATION FINE	00H 00H-01H 7FH	0-255
00H 0FH 12H	FILL TYPE	00H-01H	BUS, MATTE
00H 0FH 13H	MATTE COLOR	00H-07H	WHITE, YELLOW, CYAN, GREEN, MAGENTA, RED, BLUE, BLACK
00H 0FH 14H	EDGE TYPE	00H-04H	OFF, BORDER, DROP, SHADOW, OUTLINE
00H 0FH 15H	EDGE COLOR	00H-07H	WHITE, YELLOW, CYAN, GREEN, MAGENTA, RED, BLUE, BLACK
00H 0FH 16H	EDGE WIDTH	00H-0EH	0-14
00H 0FH 17H	DSK MODE	00H ~ 02H	SELF KEY, ALPHA KEY, EXTERNAL KEY
00H 0FH 18H	KEY SOURCE	00H ~ 0FH	HDMI 1-8, STILL 1-8
00H 0FH 19H	reserved		

○ SPLIT/VFX

* "xxH" corresponds to the respective channels as indicated below.
xxH: 10H-11H (SPLIT/VFX A, B)

Address	Parameter Name	Sys.Ex.Value	Meaning of Value
00H xxH 00H	SPLIT/VFX SW	00H-01H	OFF, ON
00H xxH 01H	SPLIT/VFX TYPE	00H-11H	SPLIT_V, SPLIT_H, PART MOSAIC, BACKGROUND MOSAIC, FULL MOSAIC, WAVE, RGB REPLACE, COLOR PASS, NEGATIVE, COLORIZE, POSTERIZE, SILHOUETTE, EMBOSS, FIND EDGES, MONOCOLOR, HUE OFFSET, SATURATION OFFSET, VALUE OFFSET
00H xxH 02H 03H	MIX LEVEL	00H 00H-01H 7FH	0-255
00H xxH 04H	PART MOSAIC MODE	00H-07H	OFF (1x1), 4 x 4, 8 x 8, 16 x 16, 32 x 32, 64 x 64, 128 x 128, 256 x 256
00H xxH 05H 06H	PART MOSAIC POSITION H	7CH 0CH-00H 00H-03H 74H	-50.0-0.0-50.0%
00H xxH 07H 08H	PART MOSAIC POSITION V	7CH 0CH-00H 00H-03H 74H	-50.0-0.0-50.0%
00H xxH 09H 0AH	PART MOSAIC AREA SIZE	00H 64H-07H 68H	10.0-100.0%
00H xxH 0BH 0CH	PART MOSAIC AREA CORRECTION H	00H 64H-07H 68H	10.0-100.0%
00H xxH 0DH 0EH	PART MOSAIC AREA CORRECTION V	00H 64H-07H 68H	10.0-100.0%
00H xxH 0FH	BG MOSAIC MODE	00H-07H	OFF (1x1), 4 x 4, 8 x 8, 16 x 16, 32 x 32, 64 x 64, 128 x 128, 256 x 256
00H xxH 10H 11H	BG MOSAIC POSITION H	7CH 0CH-00H 00H-03H 74H	-50.0-0.0-50.0%

Address	Parameter Name	Sys.Ex.Value	Meaning of Value
00H xxH 12H 13H	BG MOSAIC POSITION V	7CH 0CH–00H 00H–03H 74H	-50.0–0.0–50.0%
00H xxH 14H 15H	BG MOSAIC AREA SIZE	00H 64H–07H 68H	10.0–100.0%
00H xxH 16H 17H	BG MOSAIC AREA CORRECTION H	00H 64H–07H 68H	10.0–100.0%
00H xxH 18H 19H	BG MOSAIC AREA CORRECTION V	00H 64H–07H 68H	10.0–100.0%
00H xxH 1AH	FULL MOSAIC MODE	00H–07H	OFF (1x1), 4 x 4, 8 x 8, 16 x 16, 32 x 32, 64 x 64, 128 x 128, 256 x 256
00H xxH 1BH 1CH	WAVE GAIN	00H 00H–01H 7FH	0–255
00H xxH 1DH	WAVE TYPE	00H–07H	0–7
00H xxH 1EH	RGB REPLACE TYPE	00H–05H	OFF (R.G.B), B.R.G, G.B.R, R.B.G, G.R.B, B.G.R
00H xxH 1FH	COLOR PASS TYPE	01H–3FH	1–63
00H xxH 20H	NEGATIVE TYPE	01H–07H	Pr, Pb, PbPr, Y, YPr, YPb, YPbPr
00H xxH 21H	COLORIZE TYPE	00H–07H	1–8
00H xxH 22H	POSTERIZE LEVEL	00H–03H	1–4
00H xxH 23H	SILHOUETTE TYPE	00H–7FH	1–128
00H xxH 24H	EMBOSS TYPE	00H–7FH	1–128
00H xxH 25H	EMBOSS CONTRAST	00H–0FH	0–15
00H xxH 26H	FIND EDGES FG COLOR	00H–0FH	0–15
00H xxH 27H	FIND EDGES BG COLOR	00H–0FH	0–15
00H xxH 28H	MONOCOLOR Pb COLOR	00H–3FH	0–63
00H xxH 29H	MONOCOLOR Pr COLOR	00H–3FH	0–63
00H xxH 2AH 2BH	HUE OFFSET VALUE	00H 00H–02H 67H	0–359
00H xxH 2CH 2DH	SATURATION OFFSET VALUE	7EH 00H–00H 00H– 01H 7FH	-256–0–255
00H xxH 2EH 2FH	VALUE OFFSET VALUE	7EH 00H–00H 00H–01H 7FH	-256–0–255
00H xxH 30H 31H	SPLIT CENTER A	7CH 0CH–00H 00H–03H 74H	-50.0–0.0–50.0%
00H xxH 32H 33H	SPLIT CENTER B	7CH 0CH–00H 00H–03H 74H	-50.0–0.0–50.0%
00H xxH 34H 35H	SPLIT CENTER POSITION	7CH 0CH–00H 00H–03H 74H	-50.0–0.0–50.0%
00H xxH 36H	SPLIT BORDER COLOR	00H–07H	WHITE, YELLOW, CYAN, GREEN, MAGENTA, RED, BLUE, BLACK
00H xxH 37H	SPLIT BORDER WIDTH	00H–0EH	0–14

○ Panel

Address	Parameter Name	Sys.Ex.Value	Meaning of Value
00H 12H 00H	PGM Select	00H–07H	INPUT1–8
00H 12H 01H	PST Select	00H–07H	INPUT1–8
00H 12H 02H	AUX Select	00H–07H	INPUT1–8
00H 12H 03H 04H	AB Fader Level	00H 00H–0FH 7FH	0–2047
00H 12H 05H	AB Bus Select	00H–01H	A, B

● Audio Parameter Area

○ Audio Input

* "xxH" corresponds to the respective channels as indicated below.

xxH: 00H–08H (HDMI IN 1–8, AUDIO IN)

Address	Parameter Name	Sys.Ex.Value	Meaning of Value
01H xxH 00H 01H 02H	INPUT LEVEL	7EH 00H 00H, 7FH 79H 60H–00H 00H 00H– 00H 00H 64H	-INFdB, -80.0–0.0–10.0dB
01H xxH 03H	INPUT MUTE	00H–01H	OFF, ON
01H xxH 04H	SOLO	00H–01H	OFF, ON
01H xxH 05H	EFFECT PRESET	00H–06H	DEFAULT, MEETING, INTERVIEW, AMBIENT MIC, WINDY FIELD, DE-ESS/POPS SOFT, DE-ESS/POPS HARD
01H xxH 06H 07H	DELAY	00H 00H–27H 08H	0.0–500.0ms
01H xxH 08H	HIGH PASS FILTER 75Hz	00H–01H	OFF, ON
01H xxH 09H	NOISE GATE SW	00H–01H	OFF, ON
01H xxH 0AH 0BH	NOISE GATE THRESHOLD	79H 60H–00H 00H	-80.0–0.0dB
01H xxH 0CH	NOISE GATE RELEASE	00H–7FH	30–5000ms
01H xxH 0DH	COMPRESSOR SW	00H–01H	OFF, ON
01H xxH 0EH 0FH	COMPRESSOR THRESHOLD	7BH 28H–00H 00H	-60.0–0.0dB
01H xxH 10H	COMPRESSOR RATIO	00H–0DH	1.00:1, 1.12:1, 1.25:1, 1.40:1, 1.60:1, 1.80:1, 2.00:1, 2.50:1, 3.20:1, 4.00:1, 5.60:1, 8.00:1, 16.0:1, INF:1
01H xxH 11H	COMPRESSOR ATTACK	00H–19H	0.2–100ms
01H xxH 12H	COMPRESSOR RELEASE	00H–7FH	30–5000ms
01H xxH 13H	COMPRESSOR AUTO GAIN	00H–01H	OFF, ON
01H xxH 14H 15H	COMPRESSOR MAKEUP GAIN	7CH 70H–00H 00H–03H 10H	-40.0–0.0–40.0dB
01H xxH 16H	EQUALIZER SW	00H–01H	OFF, ON
01H xxH 17H 18H	EQUALIZER Hi GAIN	7EH 6AH–00H 00H–01H 16H	-15.0–0.0–15.0dB
01H xxH 19H	EQUALIZER Hi FREQUENCY	44H–78H	1.00–20.0kHz
01H xxH 1AH 1BH	EQUALIZER Mid GAIN	7EH 6AH–00H 00H–01H 16H	-15.0–0.0–15.0dB
01H xxH 1CH	EQUALIZER Mid FREQUENCY	00H–78H	20Hz–20.0kHz
01H xxH 1DH	EQUALIZER Mid Q	00H–05H	0.5–16.0
01H xxH 1EH 1FH	EQUALIZER Lo GAIN	7EH 6AH–00H 00H–01H 16H	-15.0–0.0–15.0dB
01H xxH 20H	EQUALIZER Lo FREQUENCY	00H–38H	20–500Hz
01H xxH 21H	MONO	00H–03H	OFF, L ONLY, R ONLY, LR MIX

○ Audio Output Assign

Address	Parameter Name	Sys.Ex.Value	Meaning of Value
01H 10H 00H	AUDIO OUT	00H–01H	MASTER OUTPUT, AUX
01H 10H 01H	PHONES OUT	00H–01H	MASTER OUTPUT, AUX
01H 10H 02H	HDMI OUTPUT 1	00H–02H	AUTO, MASTER OUTPUT, AUX
01H 10H 03H	HDMI OUTPUT 2	00H–02H	AUTO, MASTER OUTPUT, AUX
01H 10H 04H	HDMI OUTPUT 3	00H–02H	AUTO, MASTER OUTPUT, AUX

○ Audio Master Output

Address	Parameter Name	Sys.Ex.Value	Meaning of Value
01H 11H 00H 01H 02H	OUTPUT LEVEL	7EH 00H 00H, 7FH 79H 60H–00H 00H 00H–00H 00H 64H	-INFdB, -80.0–0.0–10.0dB
01H 11H 03H	OUTPUT MUTE	00H–01H	OFF, ON
01H 11H 04H	LIMITER SW	00H–01H	OFF, ON
01H 11H 05H 06H	LIMITER THRESHOLD	7CH 70H–00H 00H	-40.0–0.0dB
01H 11H 07H	EQUALIZER SW	00H–01H	OFF, ON
01H 11H 08H 09H	EQUALIZER Hi GAIN	7EH 6AH–00H 00H–01H 16H	-15.0–0.0–15.0dB
01H 11H 0AH	EQUALIZER Hi FREQUENCY	44H–78H	1.00–20.0kHz
01H 11H 0BH 0CH	EQUALIZER Mid GAIN	7EH 6AH–00H 00H–01H 16H	-15.0–0.0–15.0dB
01H 11H 0DH	EQUALIZER Mid FREQUENCY	00H–78H	20Hz–20.0kHz

Address	Parameter Name	Sys.Ex.Value	Meaning of Value
01H 11H 0EH	EQUALIZER Mid Q	00H-05H	0.5-16.0
01H 11H 0FH 10H	EQUALIZER Lo GAIN	7EH 6AH-00H 00H-01H 16H	-15.0-0.0-15.0dB
01H 11H 11H	EQUALIZER Lo FREQUENCY	00H-38H	20-500Hz
01H 11H 12H	MULTI BAND COMPRESSOR SW	00H-01H	OFF, ON
01H 11H 13H 14H	MB COMP Hi THRESHOLD	7CH 70H-00H 00H	-40.0-0.0dB
01H 11H 15H	MB COMP Hi RATIO	00H-0DH	1.00:1, 1.12:1, 1.25:1, 1.40:1, 1.60:1, 1.80:1, 2.00:1, 2.50:1, 3.20:1, 4.00:1, 5.60:1, 8.00:1, 16.0:1, INF:1
01H 11H 16H 17H	MB COMP Mid THRESHOLD	7CH 70H-00H 00H	-40.0-0.0dB
01H 11H 18H	MB COMP Mid RATIO	00H-0DH	1.00:1, 1.12:1, 1.25:1, 1.40:1, 1.60:1, 1.80:1, 2.00:1, 2.50:1, 3.20:1, 4.00:1, 5.60:1, 8.00:1, 16.0:1, INF:1
01H 11H 19H 1AH	MB COMP Lo THRESHOLD	7CH 70H-00H 00H	-40.0-0.0dB
01H 11H 1BH	MB COMP Lo RATIO	00H-0DH	1.00:1, 1.12:1, 1.25:1, 1.40:1, 1.60:1, 1.80:1, 2.00:1, 2.50:1, 3.20:1, 4.00:1, 5.60:1, 8.00:1, 16.0:1, INF:1

○ Audio AUX Output

Address	Parameter Name	Sys.Ex.Value	Meaning of Value
01H 12H 00H 01H 02H	OUTPUT LEVEL	7EH 00H 00H, 7FH 79H 60H-00H 00H 00H-00H 00H 64H	-INFdB, -80.0-0.0-10.0dB
01H 12H 03H	OUTPUT MUTE	00H-01H	OFF, ON
01H 12H 04H	LIMITER SW	00H-01H	OFF, ON
01H 12H 05H 06H	LIMITER THRESHOLD	7CH 70H-00H 00H	-40.0-0.0dB
01H 12H 07H	AUX SEND VIDEO	00H-01H	AUTO, MANUAL
01H 12H 08H	AUX SEND AUDIO IN	00H-01H	OFF, ON
01H 12H 09H	AUX EFFECT HDMI IN 1	00H-01H	DRY, WET
01H 12H 0AH	AUX EFFECT HDMI IN 2	00H-01H	DRY, WET
01H 12H 0BH	AUX EFFECT HDMI IN 3	00H-01H	DRY, WET
01H 12H 0CH	AUX EFFECT HDMI IN 4	00H-01H	DRY, WET
01H 12H 0DH	AUX EFFECT HDMI IN 5	00H-01H	DRY, WET
01H 12H 0EH	AUX EFFECT HDMI IN 6	00H-01H	DRY, WET
01H 12H 0FH	AUX EFFECT HDMI IN 7	00H-01H	DRY, WET
01H 12H 10H	AUX EFFECT HDMI IN 8	00H-01H	DRY, WET
01H 12H 11H	AUX EFFECT AUDIO IN	00H-01H	DRY, WET
01H 12H 12H 13H	AUX DELAY	00H 00H-27H 08H	0.0-500.0ms
01H 12H 14H	AUX SEND HDMI IN 1	2FH-00H	-INFdB, -80-0dB
01H 12H 15H	AUX SEND HDMI IN 2	2FH-00H	-INFdB, -80-0dB
01H 12H 16H	AUX SEND HDMI IN 3	2FH-00H	-INFdB, -80-0dB
01H 12H 17H	AUX SEND HDMI IN 4	2FH-00H	-INFdB, -80-0dB
01H 12H 18H	AUX SEND HDMI IN 5	2FH-00H	-INFdB, -80-0dB
01H 12H 19H	AUX SEND HDMI IN 6	2FH-00H	-INFdB, -80-0dB
01H 12H 1AH	AUX SEND HDMI IN 7	2FH-00H	-INFdB, -80-0dB
01H 12H 1BH	AUX SEND HDMI IN 8	2FH-00H	-INFdB, -80-0dB
01H 12H 1CH	AUX SEND AUDIO IN	2FH-00H	-INFdB, -80-0dB

○ Audio Follow

Address	Parameter Name	Sys.Ex.Value	Meaning of Value
01H 20H 00H	INPUT 1	00H-01H	OFF, ON
01H 20H 01H	INPUT 2	00H-01H	OFF, ON
01H 20H 02H	INPUT 3	00H-01H	OFF, ON
01H 20H 03H	INPUT 4	00H-01H	OFF, ON
01H 20H 04H	INPUT 5	00H-01H	OFF, ON
01H 20H 05H	INPUT 6	00H-01H	OFF, ON
01H 20H 06H	INPUT 7	00H-01H	OFF, ON
01H 20H 07H	INPUT 8	00H-01H	OFF, ON
01H 20H 08H	AUDIO IN	00H-08H	OFF, INPUT 1-8

● System Parameter Area

○ Version

Address	Parameter Name	Sys.Ex.Value	Meaning of Value
02H 00H 00H	System Version Major	00H-09H	Version Number (Read Only)
02H 00H 01H	System Version Minor (1)	00H-09H	Version Number (Read Only)
02H 00H 02H	System Version Minor (2)	00H-09H	Version Number (Read Only)

○ System

Address	Parameter Name	Sys.Ex.Value	Meaning of Value
02H 01H 00H	HDCP	00H-01H	OFF, ON
02H 01H 01H	FRAME RATE	00H-02H	60, 59.94, 50 Hz
02H 01H 02H	SYSTEM FORMAT	00H-02H	1080p, 1080i, 720p
02H 01H 03H	CUT SW ASSIGN	00H-04H	▲AUTO TAKE, ▲AUTO TAKE▼, ▲CUT, ▲CUT▼, ▲TRANSFORM
02H 01H 04H	AUTO SW ASSIGN	00H-04H	AUTO TAKE▼, ▲AUTO TAKE▼, CUT▼, ▲CUT▼, TRANSFORM▼
02H 01H 05H	PANEL OPERATION	00H-01H	A/B, PGM/PST
02H 01H 06H	AUX LINKED PGM	00H-02H	OFF, AUTO, MANUAL
02H 01H 07H	OUTPUT FADE LEFT ASSIGN	00H-0CH	BLACK, WHITE, AUDIO, BLACK&AUDIO, WHITE&AUDIO, STILL 1-8 OUTPUT
02H 01H 08H	OUTPUT FADE RIGHT ASSIGN	00H-0CH	BLACK, WHITE, AUDIO, BLACK&AUDIO, WHITE&AUDIO, STILL 1-8 OUTPUT
02H 01H 09H	USER 1 SW ASSIGN	00H-27H	N/A, FREEZE, AUTO SWITCHING, BPM TAP, INPUT 1-8 ASSIGN, STILL 1-8 OUTPUT, HDMI IN 1-8 MUTE, AUDIO IN MUTE, OUTPUT MUTE, AUX MUTE, INPUT SCAN N, INPUT SCAN R, MEMORY SCAN N, MEMORY SCAN R, REC START/STOP, SEQUENCER MODE ON/OFF, SEQUENCER NEXT, SEQUENCER PREVIOUS, SEQUENCER AUTO SEQUENCE
02H 01H 0AH	USER 2 SW ASSIGN	00H-27H	N/A, FREEZE, AUTO SWITCHING, BPM TAP, INPUT 1-8 ASSIGN, STILL 1-8 OUTPUT, HDMI IN 1-8 MUTE, AUDIO IN MUTE, OUTPUT MUTE, AUX MUTE, INPUT SCAN N, INPUT SCAN R, MEMORY SCAN N, MEMORY SCAN R, REC START/STOP, SEQUENCER MODE ON/OFF, SEQUENCER NEXT, SEQUENCER PREVIOUS, SEQUENCER AUTO SEQUENCE
02H 01H 0BH	LED DIMMER	01H-08H	1-8
02H 01H 0CH	LCD DIMMER	01H-08H	1-8
02H 01H 0DH	ON SCREEN MENU	00H-03H	UPPER LEFT, UPPER RIGHT, LOWER LEFT, LOWER RIGHT
02H 01H 0EH	TALLY FRAME	00H-01H	OFF, ON
02H 01H 0FH	AUX/PinP MARK	00H-01H	OFF, ON
02H 01H 10H	REC MARK	00H-02H	OFF, ON
02H 01H 11H	AUDIO LEVEL METER SW	00H-01H	OFF, ON
02H 01H 12H	AUDIO LEVEL METER AUDIO IN	00H-02H	OFF, LOWER, UPPER
02H 01H 13H	MULTI-VIEW LABEL	00H-01H	OFF, ON
02H 01H 14H	MULTI-VIEW LAYOUT	00H-03H	PVW.PGM, PGM.PVW, BLACK.PGM, PGM.BLACK
02H 01H 15H	OUTPUT 3 OSD ON SCREEN MENU	00H-01H	OFF, ON
02H 01H 16H	OUTPUT 3 OSD TALLY FRAME	00H-01H	OFF, ON
02H 01H 17H	OUTPUT 3 OSD LABEL/LEVEL METER/MARK	00H-01H	OFF, ON
02H 01H 18H	AUTO INPUT DETECT	00H-01H	OFF, ON
02H 01H 19H	AUTO OFF	00H-01H	OFF, ON
02H 01H 1AH	TEST PATTERN	00H-05H	OFF, 75% COLOR BAR, 100% COLOR BAR, RAMP, STEP, HATCH
02H 01H 1BH	TEST TONE LEVEL	00H-03H	OFF, -20dB, -10dB, 0dB
02H 01H 1CH	AUX SW MODE	00H-01H	OFF, ON
02H 01H 1DH	LABEL SIZE	00H-01H	SMALL, NORMAL
02H 01H 1EH	TEST TONE FREQUENCY L	00H-02H	400Hz, 1kHz, 2kHz
02H 01H 1FH	TEST TONE FREQUENCY R	00H-02H	400Hz, 1kHz, 2kHz
02H 01H 20H	reserved		
02H 01H 21H	reserved		
02H 01H 22H	reserved		
02H 01H 23H	EFFECTS TRANSITION SYNC	00H-01H	OFF, ON
02H 01H 24H	TEST PATTERN MOTION	00H-02H	DISABLE, SLOW, FAST

○ Panel Lock

Address	Parameter Name	Sys.Ex.Value	Meaning of Value
02H 02H 00H	A/PGM 1 SW	00H-01H	OFF, ON
02H 02H 01H	A/PGM 2 SW	00H-01H	OFF, ON
02H 02H 02H	A/PGM 3 SW	00H-01H	OFF, ON
02H 02H 03H	A/PGM 4 SW	00H-01H	OFF, ON
02H 02H 04H	A/PGM 5 SW	00H-01H	OFF, ON
02H 02H 05H	A/PGM 6 SW	00H-01H	OFF, ON

Address	Parameter Name	Sys.Ex.Value	Meaning of Value
02H 02H 06H	A/PGM 7 SW	00H-01H	OFF, ON
02H 02H 07H	A/PGM 8 SW	00H-01H	OFF, ON
02H 02H 08H	B/PST 1 SW	00H-01H	OFF, ON
02H 02H 09H	B/PST 2 SW	00H-01H	OFF, ON
02H 02H 0AH	B/PST 3 SW	00H-01H	OFF, ON
02H 02H 0BH	B/PST 4 SW	00H-01H	OFF, ON
02H 02H 0CH	B/PST 5 SW	00H-01H	OFF, ON
02H 02H 0DH	B/PST 6 SW	00H-01H	OFF, ON
02H 02H 0EH	B/PST 7 SW	00H-01H	OFF, ON
02H 02H 0FH	B/PST 8 SW	00H-01H	OFF, ON
02H 02H 10H	CUT SW	00H-01H	OFF, ON
02H 02H 11H	AUTO SW	00H-01H	OFF, ON
02H 02H 12H	AUX SW	00H-01H	OFF, ON
02H 02H 13H	MODE SW	00H-01H	OFF, ON
02H 02H 14H	TRANSITION SW	00H-01H	OFF, ON
02H 02H 15H	VIDEO FADER	00H-01H	OFF, ON
02H 02H 16H	VFX/SPLIT A BLOCK	00H-01H	OFF, ON
02H 02H 17H	VFX/SPLIT B BLOCK	00H-01H	OFF, ON
02H 02H 18H	PinP 1 BLOCK	00H-01H	OFF, ON
02H 02H 19H	PinP 2 BLOCK	00H-01H	OFF, ON
02H 02H 1AH	DSK BLOCK	00H-01H	OFF, ON
02H 02H 1BH	USER 1 SW	00H-01H	OFF, ON
02H 02H 1CH	USER 2 SW	00H-01H	OFF, ON
02H 02H 1DH	CAPTURE IMAGE SW	00H-01H	OFF, ON
02H 02H 1EH	OUTPUT FADE	00H-01H	OFF, ON
02H 02H 1FH	MACRO SW	00H-01H	OFF, ON

○ Preset Memory

Address	Parameter Name	Sys.Ex.Value	Meaning of Value
02H 03H 00H	START UP	00H-18H	LAST MEMORY, MEMORY 1-24
02H 03H 01H	MEMORY PROTECT	00H-01H	OFF, ON
02H 03H 02H	PinP FADE TIME	00H-0AH	0.0-1.0s
02H 03H 03H	LOAD PARAMETER / VIDEO INPUT	00H-01H	OFF, ON
02H 03H 04H	LOAD PARAMETER / VIDEO OUTPUT	00H-01H	OFF, ON
02H 03H 05H	LOAD PARAMETER / TRANSITION TIME	00H-01H	OFF, ON
02H 03H 06H	LOAD PARAMETER / MIX/WIPE	00H-01H	OFF, ON
02H 03H 07H	LOAD PARAMETER / PinP	00H-01H	OFF, ON
02H 03H 08H	LOAD PARAMETER / DSK	00H-01H	OFF, ON
02H 03H 09H	LOAD PARAMETER / VFX/SPLIT	00H-01H	OFF, ON
02H 03H 0AH	LOAD PARAMETER / AUDIO INPUT	00H-01H	OFF, ON
02H 03H 0BH	LOAD PARAMETER / AUDIO OUTPUT	00H-01H	OFF, ON
02H 03H 0CH	LOAD PARAMETER / AUDIO FOLLOW	00H-01H	OFF, ON
02H 03H 0DH	LOAD PARAMETER / CROSSPOINT	00H-01H	OFF, ON
02H 03H 0EH	LOAD PARAMETER / T-Bar	00H-01H	INITIALIZE, ON
02H 03H 0FH	NUM OF MEMORY SW	00H-01H	OFF, ON
02H 03H 10H	LOAD FADE SW / MIX/WIPE	00H-01H	OFF, ON
02H 03H 11H	LOAD FADE SW / PinP 1	00H-01H	OFF, ON
02H 03H 12H	LOAD FADE SW / PinP 2	00H-01H	OFF, ON
02H 03H 13H	LOAD FADE SW / DSK	00H-01H	OFF, ON
02H 03H 14H	LOAD PARAMETER / AUX	00H-01H	OFF, ON

○ FREEZE

Address	Parameter Name	Sys.Ex.Value	Meaning of Value
02H 04H 00H	FREEZE TYPE	00H-01H	ALL, SELECT
02H 04H 01H	FREEZE_SELECT HDMI IN 1	00H-01H	DISABLE, ENABLE
02H 04H 02H	FREEZE_SELECT HDMI IN 2	00H-01H	DISABLE, ENABLE
02H 04H 03H	FREEZE_SELECT HDMI IN 3	00H-01H	DISABLE, ENABLE
02H 04H 04H	FREEZE_SELECT HDMI IN 4	00H-01H	DISABLE, ENABLE
02H 04H 05H	FREEZE_SELECT HDMI IN 5	00H-01H	DISABLE, ENABLE
02H 04H 06H	FREEZE_SELECT HDMI IN 6	00H-01H	DISABLE, ENABLE
02H 04H 07H	FREEZE_SELECT HDMI IN 7	00H-01H	DISABLE, ENABLE
02H 04H 08H	FREEZE_SELECT HDMI IN 8	00H-01H	DISABLE, ENABLE

○ AUTO SWITCHING

Address	Parameter Name	Sys.Ex.Value	Meaning of Value
02H 05H 00H	AUTO SWITCHING SW	00H-01H	OFF, ON
02H 05H 01H	AUTO SWITCHING TYPE	00H-02H	INPUT SCAN, PRESET MEMORY SCAN, BPM SYNC
02H 05H 02H	INPUT SCAN SEQUENCE	00H-02H	NORMAL, REVERSE, RANDOM
02H 05H 03H	INPUT SCAN TRANSITION TIME	00H-28H	0.0-4.0s
02H 05H 04H	INPUT SCAN TIME / INPUT 1	00H-78H	0-120s
02H 05H 05H	INPUT SCAN TIME / INPUT 2	00H-78H	0-120s
02H 05H 06H	INPUT SCAN TIME / INPUT 3	00H-78H	0-120s
02H 05H 07H	INPUT SCAN TIME / INPUT 4	00H-78H	0-120s
02H 05H 08H	INPUT SCAN TIME / INPUT 5	00H-78H	0-120s
02H 05H 09H	INPUT SCAN TIME / INPUT 6	00H-78H	0-120s
02H 05H 0AH	INPUT SCAN TIME / INPUT 7	00H-78H	0-120s
02H 05H 0BH	INPUT SCAN TIME / INPUT 8	00H-78H	0-120s
02H 05H 0CH	MEMORY SCAN SEQUENCE	00H-02H	NORMAL, REVERSE, RANDOM
02H 05H 0DH	reserved		
02H 05H 0EH	reserved		
02H 05H 0FH	reserved		
02H 05H 10H	reserved		
02H 05H 11H	reserved		
02H 05H 12H	reserved		
02H 05H 13H	reserved		
02H 05H 14H	reserved		
02H 05H 15H 16H	BPM SYNC BPM	00H 14H-01H 7AH	20-250
02H 05H 17H	BPM SYNC MODE	00H-01H	TRANSITION, CUT
02H 05H 18H	BPM SYNC SPEED	00H-03H	x1/4, x1/2, x1, x2
02H 05H 19H	MEMORY SCAN TIME / MEMORY 1	00H-78H	0-120s
:	:		
02H 05H 30H	MEMORY SCAN TIME / MEMORY 24	00H-78H	0-120s

○ CTL/EXP

* "xxH" corresponds to the respective channels as indicated below.
xxH: 06H-07H (CTL/EXP 1, 2)

Address	Parameter Name	Sys.Ex.Value	Meaning of Value
02H xxH 00H	CTL/EXP TYPE	00H-02H	OFF, CTL A & CTL B, EXP
02H xxH 01H 02H	CTL A ASSIGN	00H 00H-02H 02H	refer to p. 83
02H xxH 03H 04H	CTL B ASSIGN	00H 00H-02H 02H	
02H xxH 05H	EXP ASSIGN	00H-19H	refer to p. 84

○ STILL IMAGE

Address	Parameter Name	Sys.Ex.Value	Meaning of Value
02H 08H 00H	SAVE TO INTERNAL STORAGE	00H ~ 01H	DISABLE, ENABLE

○ LABEL EDIT

* "xxH" corresponds to the respective channels as indicated below.
xxH: 10H-22H (HDMI 1-8, STILL 1-8, PROGRAM, PREVIEW, AUX)

Address	Parameter Name	Sys.Ex.Value	Meaning of Value
02H xxH 00H	LABEL (0)	20H-7EH	Character shown in the label (1st character)
02H xxH 01H	LABEL (1)	20H-7EH	Character shown in the label (2nd character)
02H xxH 02H	LABEL (2)	20H-7EH	Character shown in the label (3rd character)
02H xxH 03H	LABEL (3)	20H-7EH	Character shown in the label (4th character)
02H xxH 04H	LABEL (4)	20H-7EH	Character shown in the label (5th character)
02H xxH 05H	LABEL (5)	20H-7EH	Character shown in the label (6th character)
02H xxH 06H	LABEL (6)	20H-7EH	Character shown in the label (7th character)
02H xxH 07H	LABEL (7)	20H-7EH	Character shown in the label (8th character)

● Other Parameter Area

○ Memory

Address	Parameter Name	Sys.Ex.Value	Meaning of Value
0AH 00H 00H	Memory Load Trigger	00H-17H	Memory 1-24 (Write Only)
0AH 00H 01H	Memory Save Trigger	00H-17H	Memory 1-24 (Write Only)
0AH 00H 02H	Memory Initialize Trigger	00H-17H	Memory 1-24 (Write Only)
0AH 00H 03H	Loaded Memory Number	00H-17H, 7FH	Memory 1-24, Last Memory (Read Only)

● Tally Parameter Area

Address	Parameter Name	Sys.Ex.Value	Meaning of Value
0CH 00H 00H	HDMI IN 1 TALLY	00H-02H	OFF, PGM, PST (Read Only)
0CH 00H 01H	HDMI IN 2 TALLY	00H-02H	OFF, PGM, PST (Read Only)
0CH 00H 02H	HDMI IN 3 TALLY	00H-02H	OFF, PGM, PST (Read Only)
0CH 00H 03H	HDMI IN 4 TALLY	00H-02H	OFF, PGM, PST (Read Only)
0CH 00H 04H	HDMI IN 5 TALLY	00H-02H	OFF, PGM, PST (Read Only)
0CH 00H 05H	HDMI IN 6 TALLY	00H-02H	OFF, PGM, PST (Read Only)
0CH 00H 06H	HDMI IN 7 TALLY	00H-02H	OFF, PGM, PST (Read Only)
0CH 00H 07H	HDMI IN 8 TALLY	00H-02H	OFF, PGM, PST (Read Only)

● Preset Memory Area

You can load or rewrite the stored contents of the preset memories.

* The 2nd byte and 3rd byte of a Preset Memory Area address, and the value range, are in common with the Video Parameter Area (00H 00H 00H) and the Audio Parameter Area (01H 00H 00H).

Address	Parameter Name	Meaning of Value
10H 00H 00H	Video Parameter (Memory 1)	Load/rewrite video parameter stored in Memory 1
11H 00H 00H	Audio Parameter (Memory 1)	Load/rewrite audio parameter stored in Memory 1
12H 00H 00H	Video Parameter (Memory 2)	Load/rewrite video parameter stored in Memory 2
13H 00H 00H	Audio Parameter (Memory 2)	Load/rewrite audio parameter stored in Memory 2
14H 00H 00H	Video Parameter (Memory 3)	Load/rewrite video parameter stored in Memory 3
15H 00H 00H	Audio Parameter (Memory 3)	Load/rewrite audio parameter stored in Memory 3
16H 00H 00H	Video Parameter (Memory 4)	Load/rewrite video parameter stored in Memory 4
17H 00H 00H	Audio Parameter (Memory 4)	Load/rewrite audio parameter stored in Memory 4
18H 00H 00H	Video Parameter (Memory 5)	Load/rewrite video parameter stored in Memory 5
19H 00H 00H	Audio Parameter (Memory 5)	Load/rewrite audio parameter stored in Memory 5
1AH 00H 00H	Video Parameter (Memory 6)	Load/rewrite video parameter stored in Memory 6
1BH 00H 00H	Audio Parameter (Memory 6)	Load/rewrite audio parameter stored in Memory 6
1CH 00H 00H	Video Parameter (Memory 7)	Load/rewrite video parameter stored in Memory 7
1DH 00H 00H	Audio Parameter (Memory 7)	Load/rewrite audio parameter stored in Memory 7
1EH 00H 00H	Video Parameter (Memory 8)	Load/rewrite video parameter stored in Memory 8
1FH 00H 00H	Audio Parameter (Memory 8)	Load/rewrite audio parameter stored in Memory 8
:	:	
3EH 00H 00H	Video Parameter (Memory 24)	Load/rewrite video parameter stored in Memory 24
3FH 00H 00H	Audio Parameter (Memory 24)	Load/rewrite audio parameter stored in Memory 24

● Preset Memory Name Area

xxH: 00H-17H (MEMORY 1-24)

Address	Parameter Name	Meaning of Value
60H xxH 00H	NAME (0)	Name of preset memory number xx (1st character)
60H xxH 01H	NAME (1)	Name of preset memory number xx (2nd character)
60H xxH 02H	NAME (2)	Name of preset memory number xx (3rd character)
60H xxH 03H	NAME (3)	Name of preset memory number xx (4th character)
60H xxH 04H	NAME (4)	Name of preset memory number xx (5th character)
60H xxH 05H	NAME (5)	Name of preset memory number xx (6th character)
60H xxH 06H	NAME (6)	Name of preset memory number xx (7th character)
60H xxH 07H	NAME (7)	Name of preset memory number xx (8th character)

3. Supplementary Material

Decimal and Hexadecimal Table

(Hexadecimal Numbers are Indicated by 'H')

In MIDI documentation, data values and addresses/sizes of exclusive messages etc. are expressed as hexadecimal values for each 7 bits.

The following table shows how these correspond to decimal numbers.

D	H	D	H	D	H	D	H
0	00H	32	20H	64	40H	96	60H
1	01H	33	21H	65	41H	97	61H
2	02H	34	22H	66	42H	98	62H
3	03H	35	23H	67	43H	99	63H
4	04H	36	24H	68	44H	100	64H
5	05H	37	25H	69	45H	101	65H
6	06H	38	26H	70	46H	102	66H
7	07H	39	27H	71	47H	103	67H
8	08H	40	28H	72	48H	104	68H
9	09H	41	29H	73	49H	105	69H
10	0AH	42	2AH	74	4AH	106	6AH
11	0BH	43	2BH	75	4BH	107	6BH
12	0CH	44	2CH	76	4CH	108	6CH
13	0DH	45	2DH	77	4DH	109	6DH
14	0EH	46	2EH	78	4EH	110	6EH
15	0FH	47	2FH	79	4FH	111	6FH
16	10H	48	30H	80	50H	112	70H
17	11H	49	31H	81	51H	113	71H
18	12H	50	32H	82	52H	114	72H
19	13H	51	33H	83	53H	115	73H
20	14H	52	34H	84	54H	116	74H
21	15H	53	35H	85	55H	117	75H
22	16H	54	36H	86	56H	118	76H
23	17H	55	37H	87	57H	119	77H
24	18H	56	38H	88	58H	120	78H
25	19H	57	39H	89	59H	121	79H
26	1AH	58	3AH	90	5AH	122	7AH
27	1BH	59	3BH	91	5BH	123	7BH
28	1CH	60	3CH	92	5CH	124	7CH
29	1DH	61	3DH	93	5DH	125	7DH
30	1EH	62	3EH	94	5EH	126	7EH
31	1FH	63	3FH	95	5FH	127	7FH

D: decimal

H: hexadecimal

* Decimal expressions used for MIDI channel, bank select, and program change are 1 greater than the decimal value shown in the above table.

* Hexadecimal values in 7-bit units can express a maximum of 128 levels in one byte of data. If the data requires greater resolution, two or more bytes are used. For example, a value indicated by a hexadecimal expression in two 7-bit bytes aa bbH would be $aa \times 128 + bb$.

* Data marked "nibbled" is expressed in hexadecimal in 4-bit units. A value expressed as a 2-byte nibble 0a 0bH has the value of $a \times 16 + b$.

<Example 1>

What is the decimal expression of 5AH?

From the preceding table, 5AH = 90

<Example 2>

What is the decimal expression of the value 12 34H given as hexadecimal for each 7 bits?

From the preceding table, since 12H = 18 and 34H = 52

$18 \times 128 + 52 = 2356$

<Example 3>

What is the decimal expression of the nibbled value 0A 03 09 0D?

From the preceding table, since 0AH = 10, 03H = 3, 09H = 9, 0DH = 13

$((10 \times 16 + 3) \times 16 + 9) \times 16 + 13 = 41885$

<Example 4>

What is the nibbled expression of the decimal value 1258?

16) 1258

16) 78... 10

16) 4... 14

0... 4

Since from the preceding table, 0 = 00H, 4 = 04H, 14 = 0EH, 10 = 0AH, the answer is 00 04 0E 0AH.

MIDI Message Examples

<Example 1> 92H 3EH 5FH

9n is a note on status and n is the MIDI channel number.

As 2H = 2, 3EH = 62 and 5FH = 95, this is a note on message of MIDI CH = 3, note number 62 (D4) and velocity 95.

<Example 2> CEH 49H

CnH is program change status, and n is the MIDI channel number.

As EH = 14 and 49H = 73, this is a program change message of MIDI CH = 15 and program number 74 (in the GS sound map, Flute).

Example of an Exclusive Message and Calculating a Checksum

Roland Exclusive messages are transmitted with a checksum at the end (before F7) to make sure that the message was correctly received. The value of the checksum is determined by the address and data (or size) of the transmitted exclusive message.

How to Calculate the Checksum

(Hexadecimal Numbers are Indicated by 'H')

The checksum is a value that produces a lower 7 bits of zero when the address, size, and checksum itself are summed. If the exclusive message to be transmitted has an address of aa bb cCH and the data is dd ee ffH, the actual calculation would be as follows:

$aa + bb + cc + dd + ee + ff = \text{sum}$

$\text{sum} / 128 = \text{quotient} \dots \text{remainder}$

$128 - \text{remainder} = \text{checksum}$

(However, the checksum will be 0 if the remainder is 0.)

<Example>

Setting Dissolve Time Ctrl Assign in MIDI Visual Control to Modulation for Control Changes

From the "Parameter Address Map", the start address of the Dissolve Time Ctrl Assign in MIDI Visual Control is 10H 10H 02H and the Modulation parameter in Control Change is 00H 01H. Therefore ...

F0H	7EH	00H	0CH 01H	10H 10H 02H	00H 01H	??H	F7H
(1)	(2)	(3)	(4)	(5)	(6)	(7)	(8)

(1) Exclusive Status

(2) ID Number (Universal SysEx Non Realtime)

(3) Device ID (0)

(4) Sub ID (MIDI Visual Control Version 1.0)

(5) Address

(6) Data

(7) Checksum

(8) EOX

Next calculate the checksum. Add (5) to (6).

$10H + 10H + 02H + 00H + 01H = 16 + 16 + 2 + 0 + 1 = 35$ (sum)

35 (sum) / $128 = 0$ (quotient) ... 35 (remainder)

Checksum = $128 - 35$ (remainder) = $93 = 5DH$

Thus, the message to transmit is :

F0H 7EH 00H 0CH 01H 10H 10H 02H 00H 01H 5DH F7H

MIDI Implementation Chart

Function		Transmitted	Recognized	Remarks
Basic Channel	Default	1	1	
	Changed	1	1	
Mode	Default	×	×	
	Messages Altered	×	×	
		*****	*****	
Note Number	True Voice	×	×	
Velocity	Note On	×	×	
	Note Off	×	×	
After Touch	Key's	×	×	
	Channel's	×	×	
Pitch Bend		×	×	
Control Change		0-9	×	Controls various parameters
		10-31	×	
		32-46	×	
		46-51	×	
		52-65	×	
		66-119	×	
			×	
Program Change	: True Number	×	O 1-8	
System Exclusive		O	O	
System Common	: Song Position	×	×	
	: Song Select	×	×	
	: Tune Request	×	×	
System Real Time	: Clock	×	×	
	: Commands	×	×	
Aux Messages	: All Sound Off	×	×	
	: Reset All Controllers	×	×	
	: Local On/Off	×	×	
	: All Notes Off	×	×	
	: Active Sensing	×	×	
	: System Reset	×	×	
Notes				

VIDEO Block Diagram

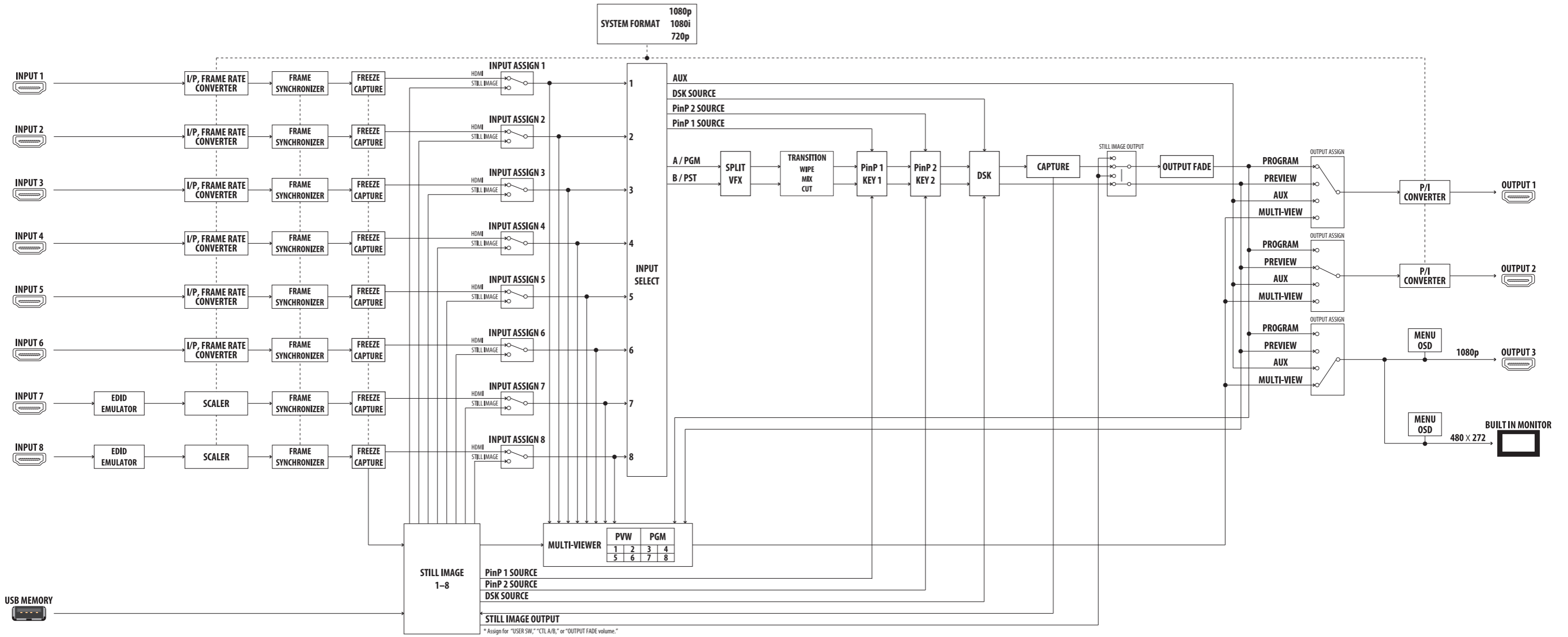

AUDIO Block Diagram

